

VEICHI

Electrohydraulic Servo Drive





Shenzhen Veichi Electric Co., Ltd. is a high-tech enterprise that is professionally engaged in the development, manufacturing and marketing of industrial automation control products, and committed to becoming a global leading provider of industrial automation control products and system solutions.

The company owns powerful R&D team, relatively perfect production system, independent intellectual property and manufacturing bases in Shenzhen and Suzhou. To improve our R&D strength, we keep on introducing advanced overseas technology and broadening our partnerships with first-class universities and research institutions. The main products of Veichi Electric include a variety of Variable Frequency Drive (VFD), Servo Drive System, Photovoltaic Inverter, PLC, HMI, Automation Equipment, etc, which are widely used in industries such as oil & gas, chemical industry, ceramic, crane & hoist, metallurgy, electrical cable and wire, plastic, print and package, textile, metal work and cable, coal mining and municipal engineering. Suitable solutions and products are always ready to meet the demands and improve comprehensive competitiveness of users.

With the spirit of "Innovation is the lifeblood of Veichi", we're committed to becoming one of the leading providers of electric drives, industrial control and green energy products. Veichi has set up more than 40 branch offices in China and dozens of partners in Asia, Europe and Africa. Veichi has been named Chinese Electric Industry's Top Ten National Brands, Chinese Electric Industry Top Ten Satisfying Brands and Top Ten National Brands of Inverter Industry. Veichi products have become the first choice of many enterprises.



Product and Applications

Electro-hydraulic servo system combined both electrical and hydraulic characteristics can accurately follow the command changes to adjust the output. With high precision, fast response, big output power, flexible signal processing, easy to control, etc., it is widely used in various industries.

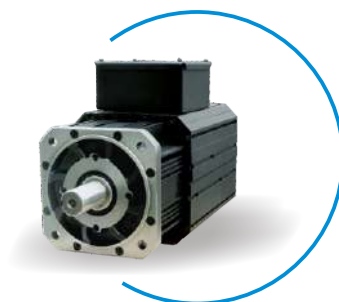
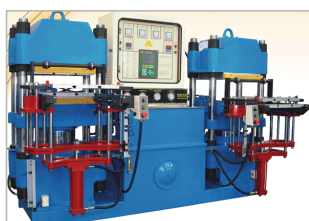

Features:

1. Built-in brake unit.
2. Built-in CAN communication, RS485 communication function.
3. Strong overload capacity: 150% rated current 60s, 180% rated current 5s.
4. Various protection functions such as phase loss, short circuit, overheating detection and etc.
5. Air cooling, liquid cooling way, suitable for different environments.
6. High-performance servo control: vector control + field weakening control + PID control.
7. Support 0-10V DC / 4-20mA direct analog signal input.
8. Fast and safe isolated terminal wiring.
9. Support 0-1000m analog signal input (with our special conversion board)
10. Start torque: 0Hz 180%; Steady speed accuracy: $\pm 0.02\%$; Torque control accuracy: $\pm 2\%$
11. Support a variety of signal reference modes (analog, CAN communication, 485/422 communication, internal instructions, terminal instructions).

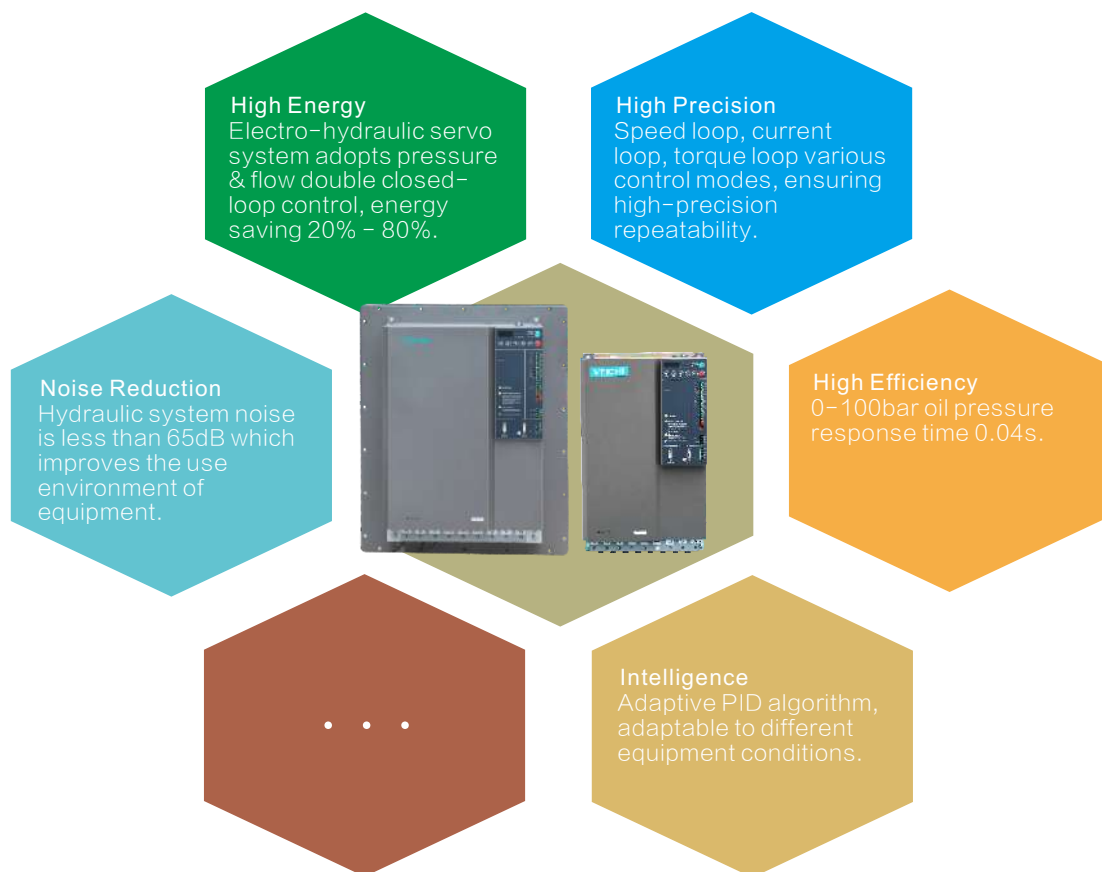

Single and Double Pump System

Single pump system

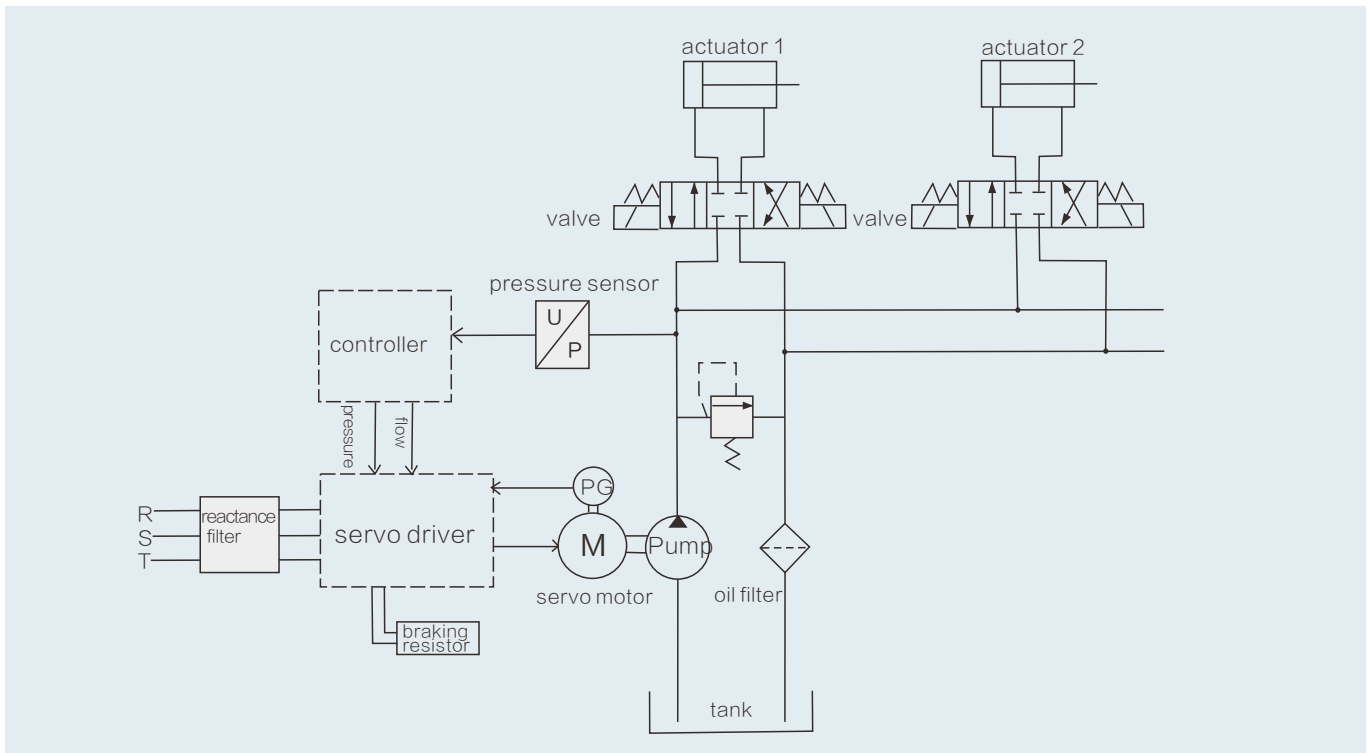

Double pump system

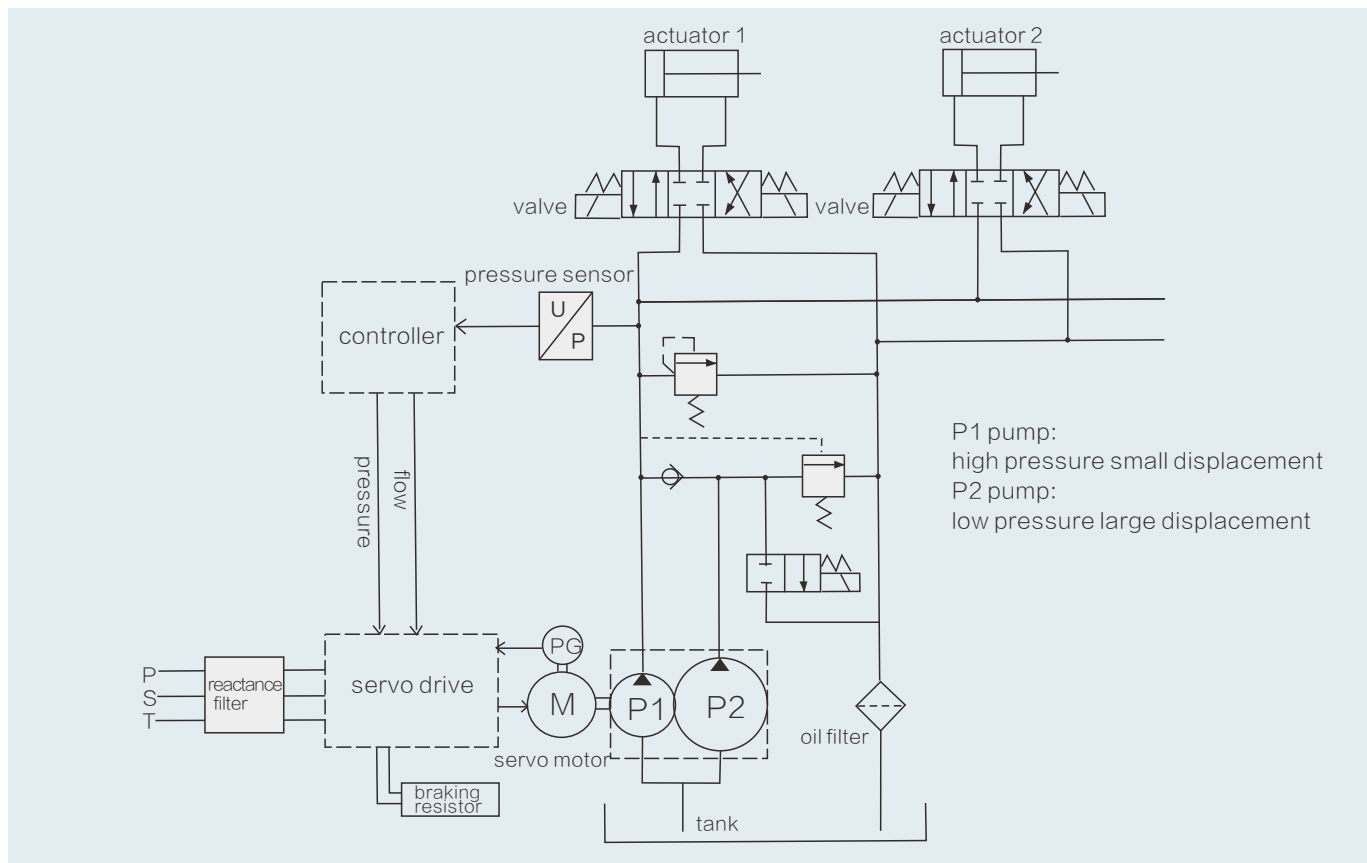

Flow-Converging System and Flow-Dividing System

Multi-pump flow-converging system

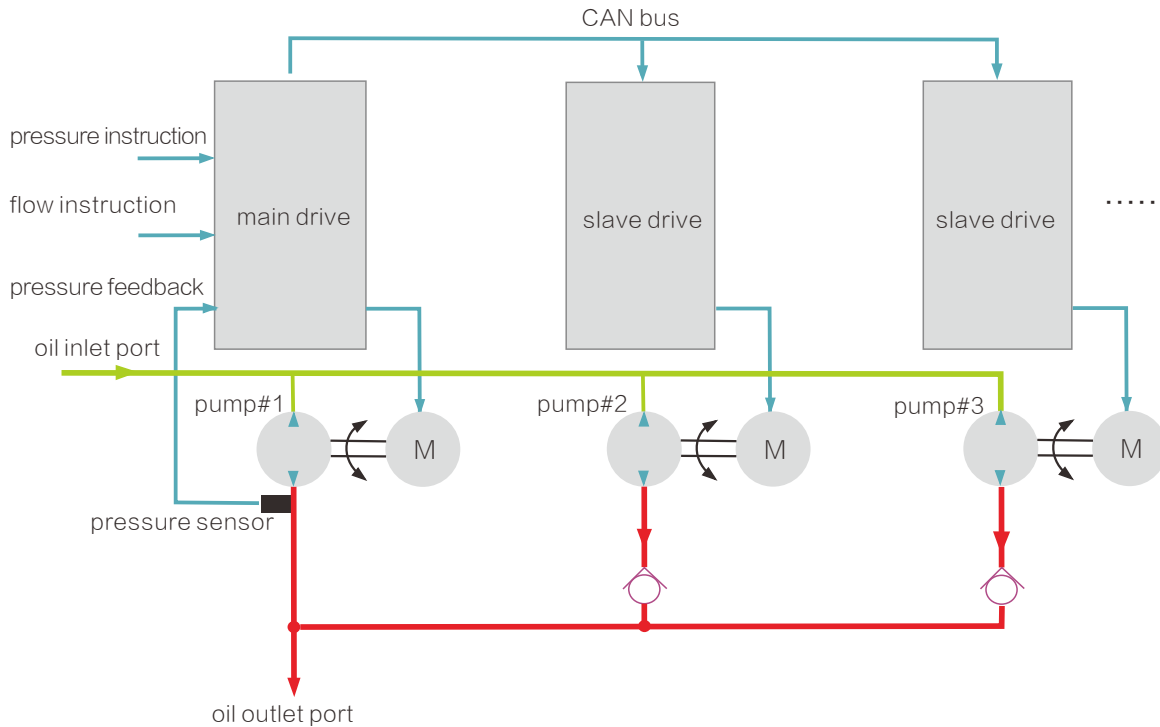

Multi-pump flow-converging system and flow-dividing system

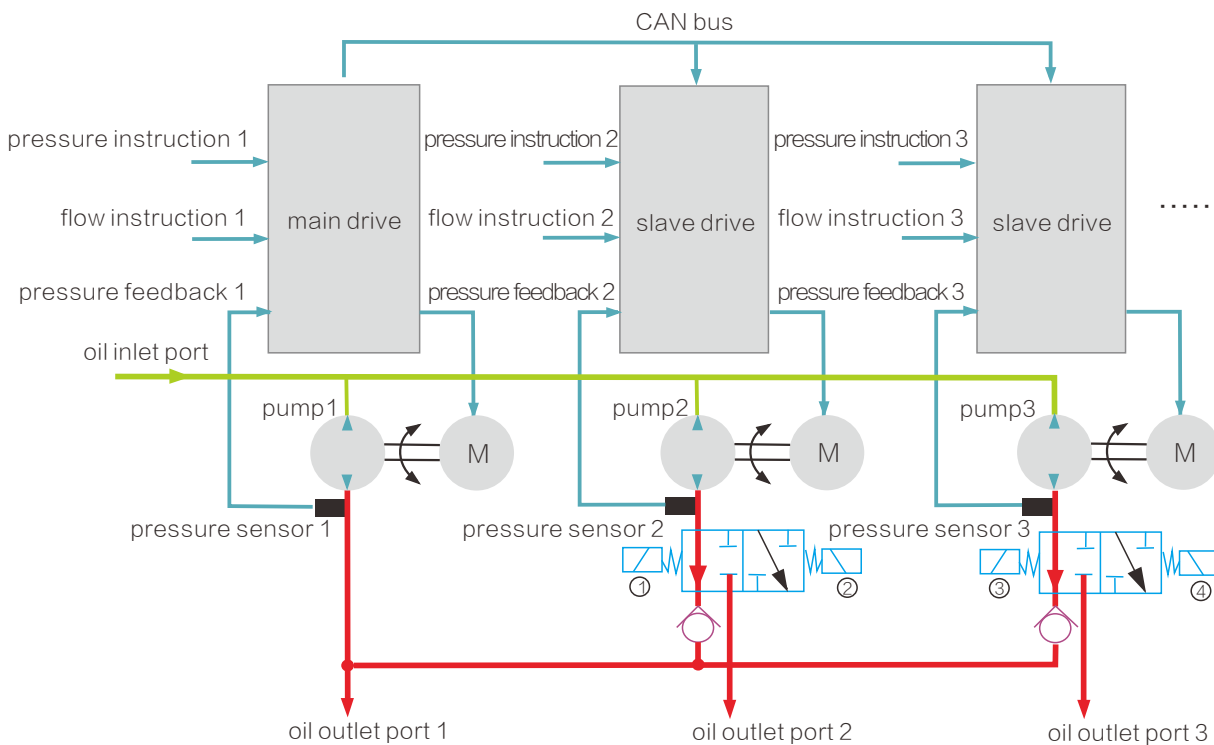

In the multi-pump flow-converging system, the slave machine can be switched to separate system via the electromagnetic valve in order to achieve switching control between flow-converging mode and flow-dividing mode.

Wiring Diagram of Servo Drive

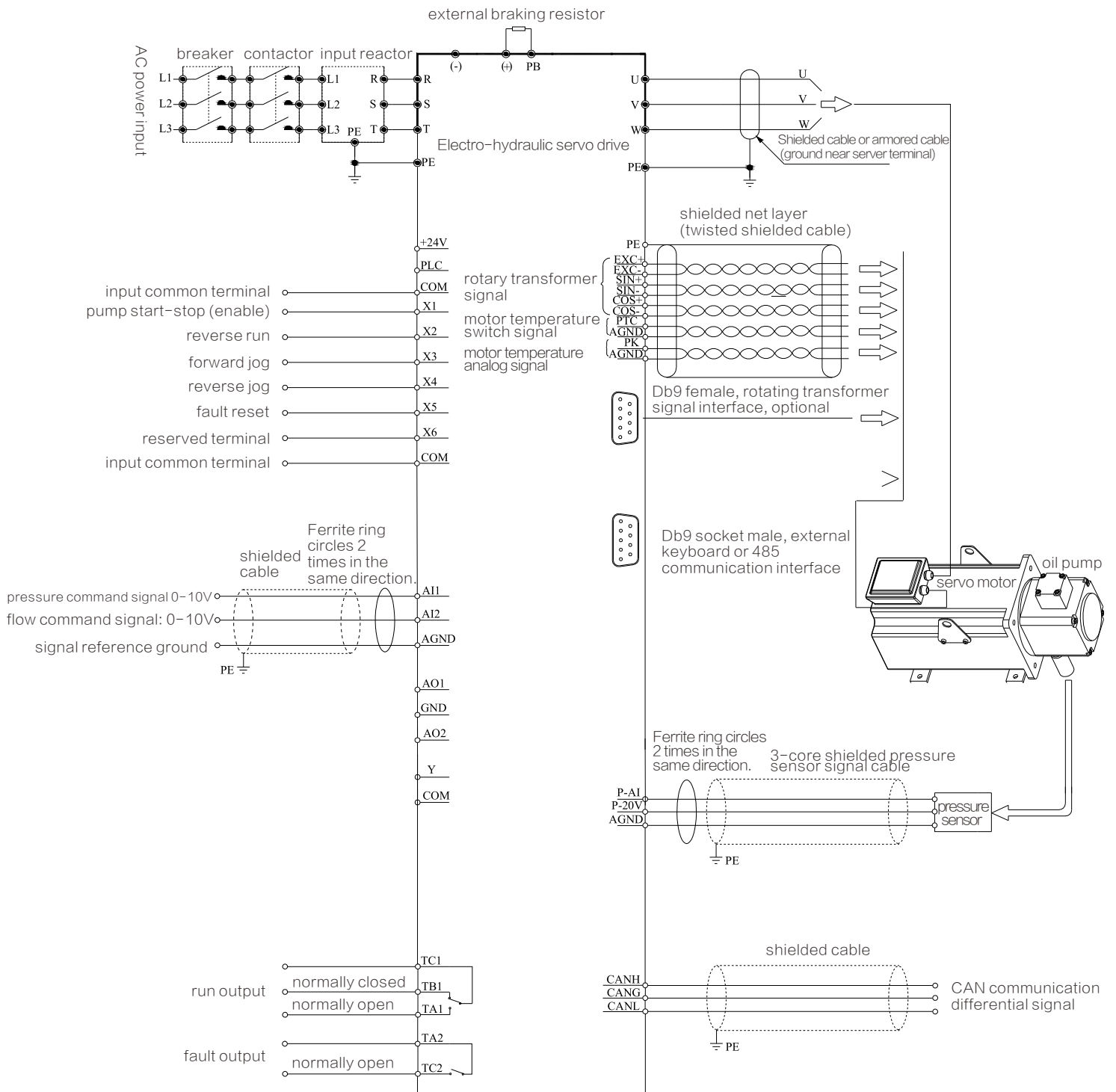

Legend: 1. ● Stand for the main circuit terminal.
2. ○ Stand for the control circuit terminal.

Main Circuit Terminal Wiring Diagram and Device Selection

Main circuit wiring diagram

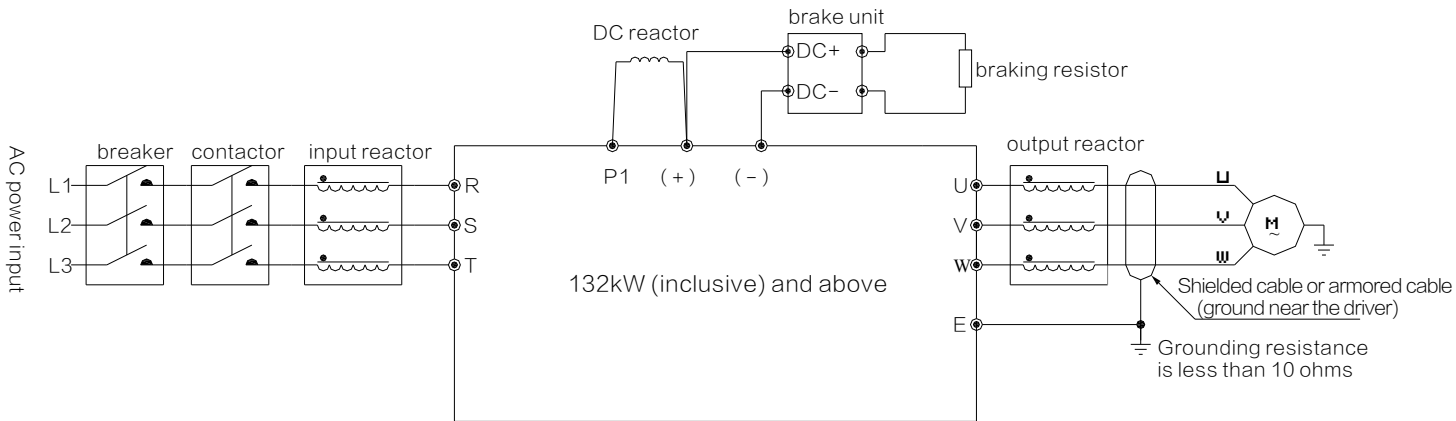
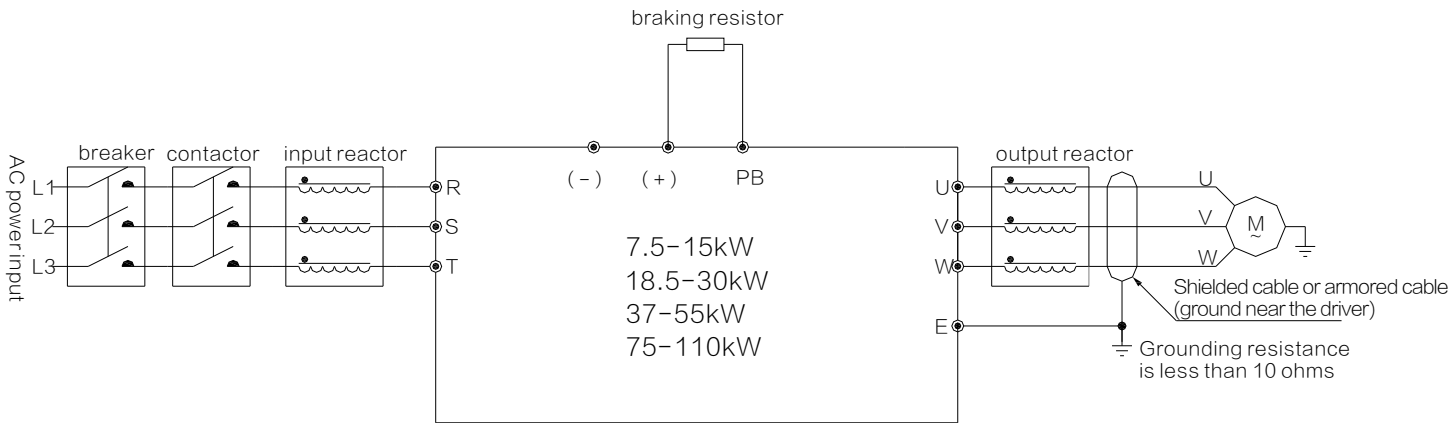

SD650 series servo drive main circuit wiring diagram

Note:

1. Fuse, DC reactor, brake unit, braking resistor, input reactor, input filter, output reactor are accessories.
2. The P1 terminal and the (+) terminal are shorted at the factory. If you need an external DC reactor, please remove the short-connected piece between the P1 terminal and the (+) terminal.

Main circuit terminal arrangement and definition

7.5 - 15kW main circuit terminal arrangement order

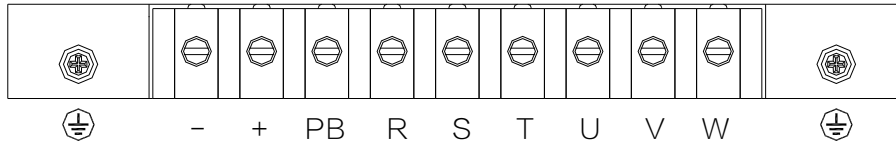

18.5 - 30kW main circuit terminal arrangement order

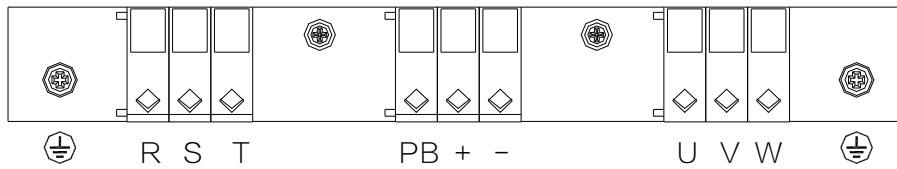

37 - 110kW main circuit terminal arrangement order

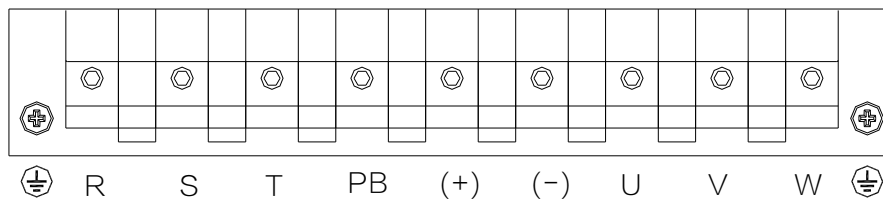

Terminal symbol	Terminal name	Terminal function definition
(-)	DC power supply terminal	DC power output, (-) is the DC bus negative, (+) is the DC bus positive, used for connecting external braking unit or common DC bus.
(+)		
(+)	Brake resistor terminal	Used for connecting external braking resistor, to achieve rapid shutdown.
PB		
P1	DC reactor terminal	Used for connecting external DC reactor
(+)		
R	Input terminal of driver	Used for connecting three-phase AC power
S		
T		
U	Output terminal of driver	Used for connecting the motor
V		
W		
⊕	Ground	Ground terminal, grounding resistance < 10ohms
PE		

Mounting Dimensions

SD650 air-cooled series installation size (see table for the remaining size)

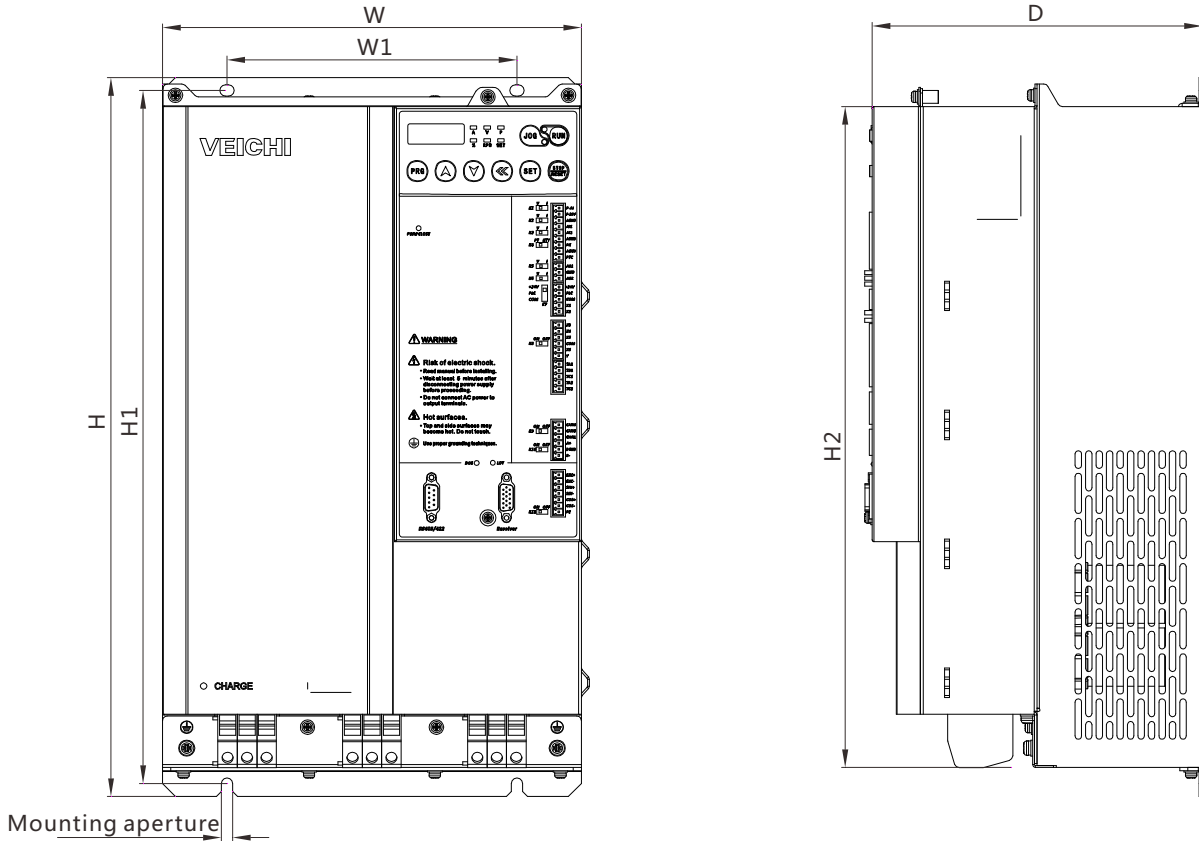

Servo controller model	W	W1	H	H1	H2	D	Mounting aperture
SD650-T3-7R5-AC	210	160	328	314	294	150	Φ7
SD650-T3-011-AC							
SD650-T3-015S-AC							
SD650-T3-018S-AC							
SD650-T3-018-AC	260	180	446	430	410	190	Φ7
SD650-T3-022-AC							
SD650-T3-030-AC							
SD650-T3-037-AC	320	180	568	534	518	260	Φ10
SD650-T3-045-AC							
SD650-T3-055-AC							
SD650-T3-075-AC	380	240	620	595	564	290	Φ11
SD650-T3-090-AC							
SD650-T3-110-AC							

SD650 liquid cooling series installation size (see table for the remaining size)

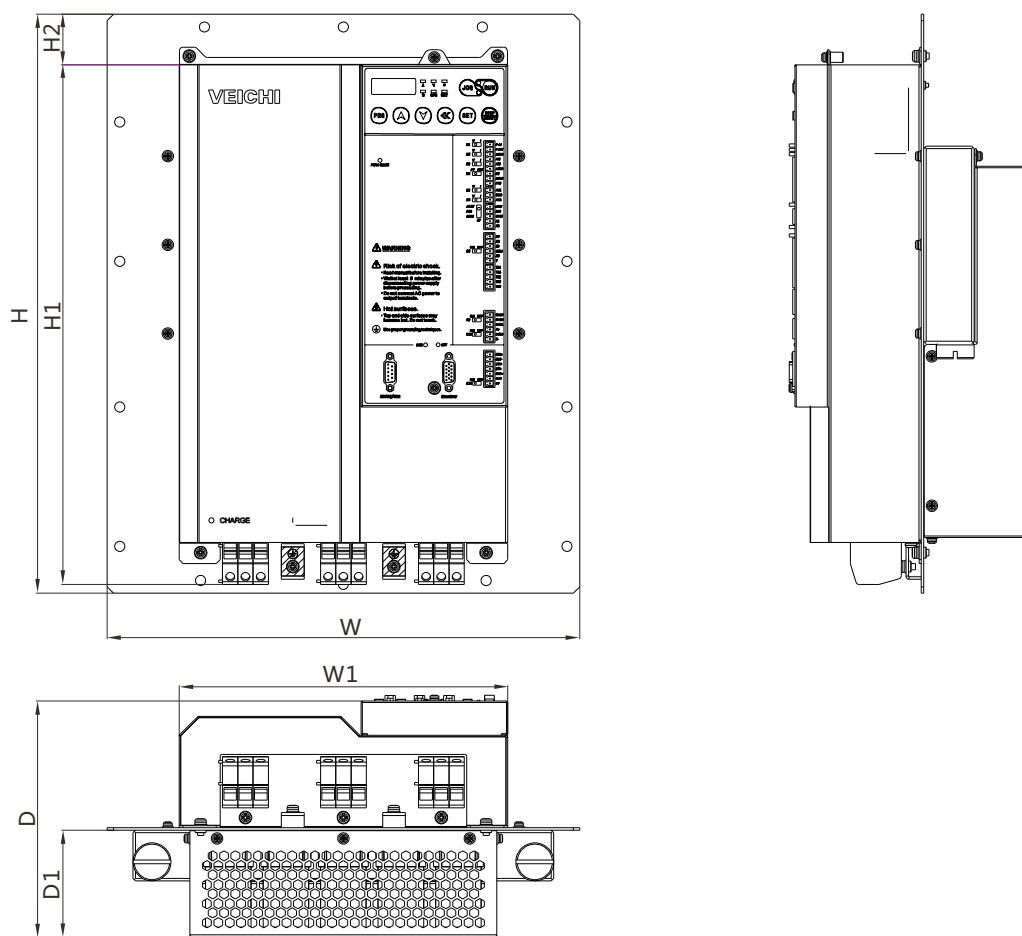

Driver model	W	W1	H	H1	H2	D	D1	Mounting aperture
SD650-T3-7R5-LC	210	160	328	314	294	150	72	Φ7
SD650-T3-011-LC								
SD650-T3-015-LC								
SD650-T3-018-LC	260	180	446	430	410	190	85	Φ7
SD650-T3-022-LC								
SD650-T3-030-LC								
SD650-T3-037-LC	320	180	568	534	518	260	138	Φ10
SD650-T3-045-LC								
SD650-T3-055-LC								
SD650-T3-075-LC	380	240	620	595	564	290	138	Φ11
SD650-T3-090-LC								
SD650-T3-110-LC								

Mounting hole of SD650 series servo driver

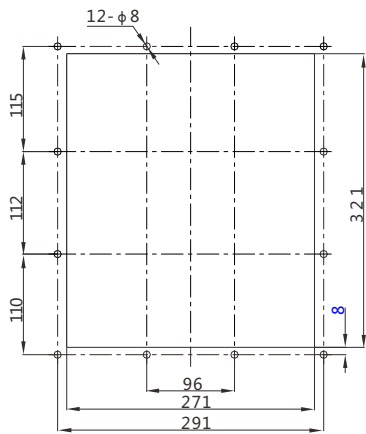

7.5kW - 15kW installation mounting hole

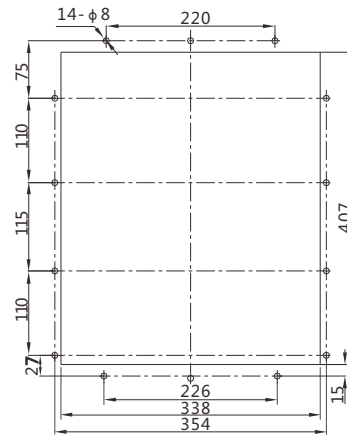

18.5kW - 30kW installation mounting hole

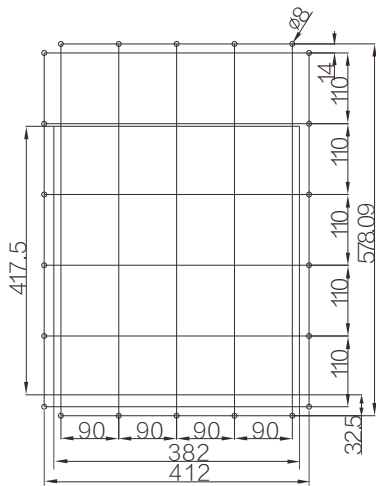

37kW - 55kW installation mounting hole

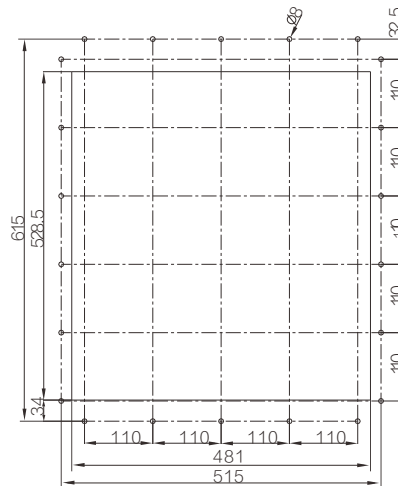

75kW - 110kW installation mounting hole

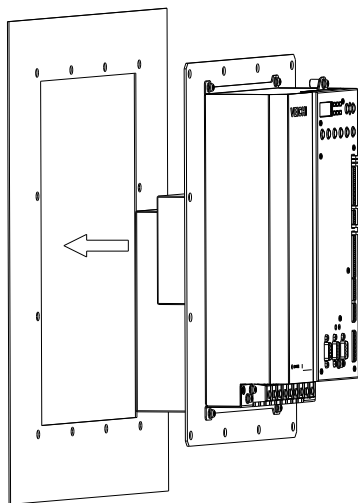

Technical Parameters and Installation Dimensions of Motor

S18F series installation size (see table for the remaining sizes)

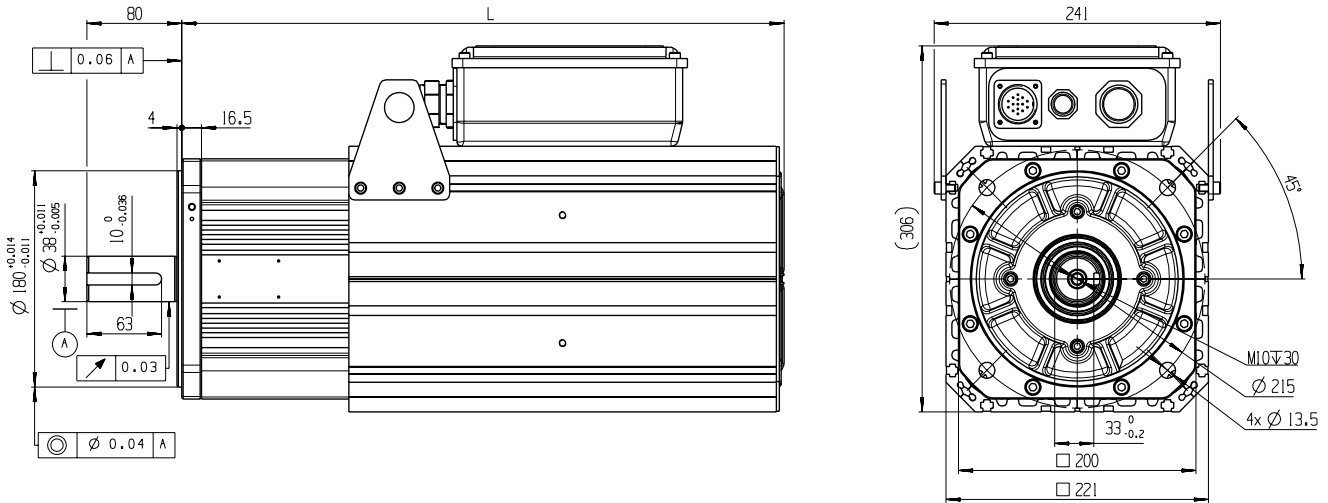

Motor model	Rated torque (N·m)	Rated current (N·m)	Rated power (kW)	Rated speed (rpm)	Rated frequency (Hz)	Torque factor (N·m/A)	Back EMF (V/rpm)	Resistance (Ω)	Inductance (Mh)	Moment of inertia (kg·m ²)	L
S1835F15A	35	10.4	5.5	1500	100	3.38	1.95	1.922	18.036	5.8	365
S1835F18A	35	12.7	6.6	1800	120	2.76	1.6	1.311	12.074	5.8	365
S1835F20A	35	13.4	7.3	2000	133	2.61	1.51	1.238	10.77	5.8	365
S1855F15A	55	15.9	8.6	1500	100	3.46	2	1.162	12.577	7.2	405
S1855F18A	55	19.9	10.4	1800	120	2.76	1.6	0.723	8.049	7.2	405
S1855F20A	55	21.7	11.5	2000	133	2.53	1.46	0.569	6.764	7.2	405
S1870F15A	70	20.7	11	1500	100	3.38	1.95	0.712	9.018	8.6	438
S1870F18A	70	25.3	13.2	1800	120	2.76	1.6	0.486	6.037	8.6	438
S1870F20A	70	28.5	14.7	2000	133	2.46	1.42	0.398	4.77	8.6	438
S1888F15A	88	25.5	13.8	1500	100	3.46	2	0.564	7.546	10	475
S1888F18A	88	30.6	16.6	1800	120	2.88	1.66	0.403	5.24	10	475
S1888F20A	88	32.7	18.4	2000	133	2.69	1.55	0.351	4.565	10	475
S18105F15A	105	32.5	16.5	1500	100	3.23	1.86	0.4	5.478	11.4	508
S18105F18A	105	38	19.8	1800	120	2.76	1.6	0.303	4.025	11.4	508
S18105F20A	105	38	22	2000	133	2.76	1.6	0.303	4.025	11.4	508
S18127F15A	127	39.4	19.9	1500	100	3.23	1.6	0.34	4.695	12.8	580
S18127F18A	127	47.2	23.9	1800	120	2.69	1.55	0.229	3.261	12.8	580
S18127F20A	127	39.4	19.9	1500	100	3.23	1.6	0.34	4.695	12.8	580
S18140F15A	140	41.4	22	1500	100	3.38	1.95	0.326	4.509	14.2	580
S18140F18A	140	50.6	26.4	1800	120	2.76	1.6	0.219	3.018	14.2	580
S18140F20A	140	57	29.3	2000	133	2.46	1.42	0.164	2.385	14.2	580

S25F series installation size (see table for the remaining sizes)

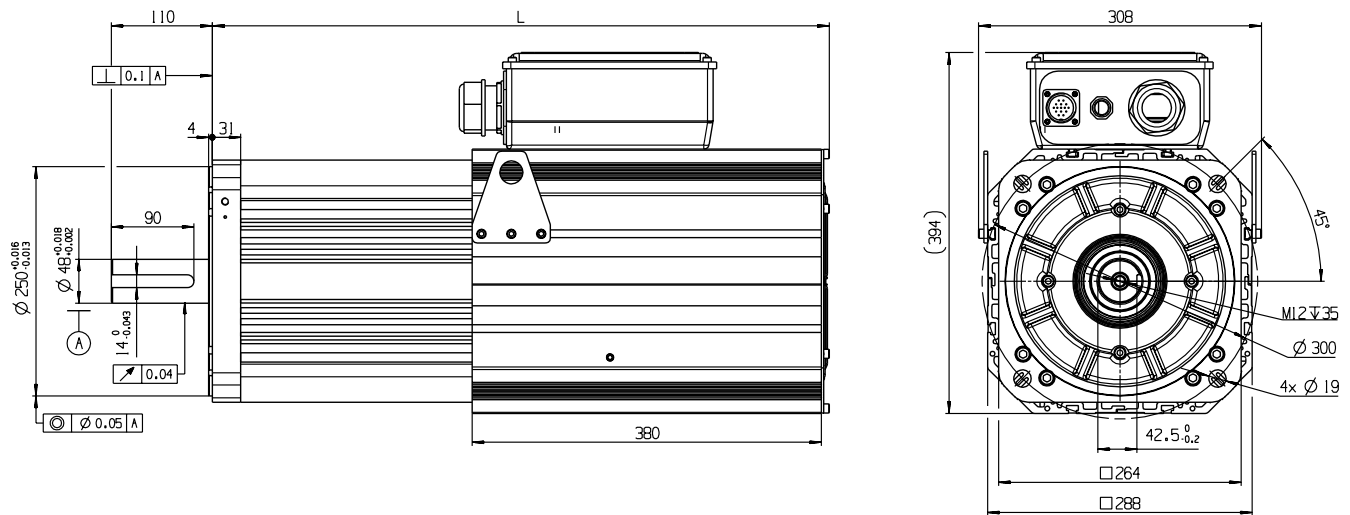

Motor model	Rated torque (N·m)	Rated current (A)	Rated power (kW)	Rated speed (rpm)	Rated frequency (Hz)	Torque factor (N·m/A)	Back EMF (V/rpm)	Resistance (Ω)	Inductance (mH)	Moment of inertia ($\text{kg}\cdot\text{m}^2$)	L
S25160F15A	160	46.8	25.1	1500	100	3.42	1.97	0.232	6.248	27	475
S25160F18A	160	52.7	30.2	1800	120	3.04	1.75	0.17	4.937	27	475
S25160F20A	160	60.2	33.5	2000	133	2.66	1.53	0.143	3.78	27	475
S25210F15A	210	59.3	33	1500	100	3.54	2.05	0.173	3.54	35	515
S25210F18A	210	69.1	39.6	1800	120	3.04	1.75	0.126	3.724	35	515
S25210F20A	210	83	44	2000	133	2.53	1.46	0.087	2.586	35	515
S25260F15A	260	74.7	40.8	1500	100	3.48	2.01	0.121	3.926	42	555
S25260F18A	260	91.3	49	1800	120	2.85	1.64	0.082	2.628	42	555
S25260F20A	260	102.7	54.5	2000	133	2.53	1.46	0.066	2.076	42	555
S25320F15A	320	93.6	50.3	1500	100	3.42	1.97	0.094	3.161	50	595
S25320F18A	320	105.3	60.3	1800	120	3.04	1.75	0.075	2.497	50	595
S25320F20A	320	120.4	67	2000	133	2.66	1.53	0.116	1.192	50	595
S25360F15A	360	101.6	56.5	1500	100	3.54	2.05	0.085	2.919	57	635
S25360F18A	360	135.4	67.9	1800	120	2.66	1.53	0.048	1.642	57	635
S25360F20A	360	135.4	75.4	2000	133	2.66	1.53	0.048	1.642	57	635
S25360F20A	360	135.4	75.4	2000	133	2.66	1.53	0.048	1.642	57	635
S25400F15A	400	112.9	68.2	1500	100	3.54	2.05	0.145	2.557	64	675
S25400F18A	400	131.7	75.4	1800	120	3.04	1.75	0.053	1.879	64	675
S25400F20A	400	158	83.8	2000	133	2.53	1.46	0.037	1.305	64	675
S25440F15A	440	128.7	69.1	1500	100	3.42	1.97	0.059	2.115	72	675
S25440F18A	440	154.5	82.9	1800	120	2.85	1.64	0.04	1.469	72	675
S25440F20A	440	193.1	92.1	2000	133	2.28	1.32	0.026	0.94	72	675

S25W series installation size

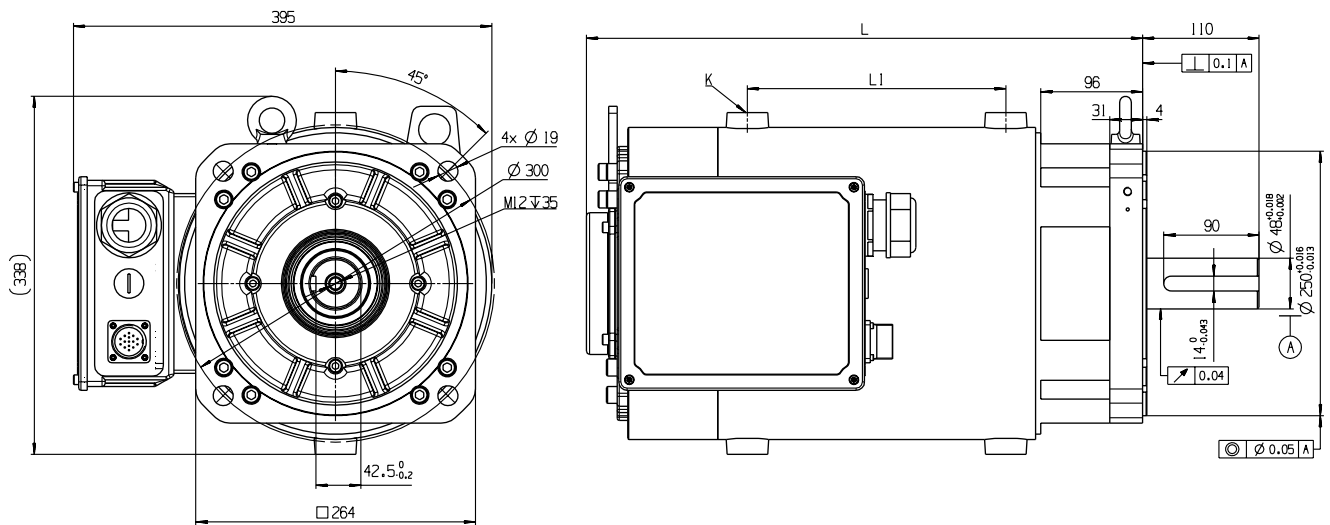

Motor model	Rated torque (N·m)	Rated current (N·m)	Rated power (kW)	Rated speed (rpm)	Rated frequency (Hz)	Torque factor (N·m/A)	Back EMF (V/rpm)	Resistance (Ω)	Inductance (Mh)	Moment of inertia (kg·m ²)	L (mm)	L1 (mm)	K
S25160W15A	160	46.8	25.1	1500	100	3.42	1.97	0.232	6.248	27	368	90	RC3/8
S25160W18A	160	52.7	30.2	1800	120	3.04	1.75	0.17	4.937	27	368	90	RC3/8
S25160W20A	160	60.2	33.5	2000	133	2.66	1.53	0.143	3.78	27	368	90	RC3/8
S25210W15A	210	59.3	33	1500	100	3.54	2.05	0.173	3.54	35	408	130	RC3/8
S25210W18A	210	69.1	39.6	1800	120	3.04	1.75	0.126	3.724	35	408	130	RC3/8
S25210W20A	210	83	44	2000	133	2.53	1.46	0.087	2.586	35	408	130	RC3/8
S25260W15A	260	74.7	40.8	1500	100	3.48	2.01	0.121	3.926	42	448	170	RC3/8
S25260W18A	260	91.3	49	1800	120	2.85	1.64	0.082	2.628	42	448	170	RC3/8
S25260W20A	260	102.7	54.5	2000	133	2.53	1.46	0.066	2.076	42	448	170	RC3/8
S25320W15A	320	93.6	50.3	1500	100	3.42	1.97	0.094	3.161	50	488	210	RC3/8
S25320W18A	320	105.3	60.3	1800	120	3.04	1.75	0.075	2.497	50	488	210	RC3/8
S25320W20A	320	120.4	67	2000	133	2.66	1.53	0.116	1.192	50	488	210	RC3/8
S25360W15A	360	101.6	56.5	1500	100	3.54	2.05	0.085	2.919	57	553	250	RC3/8
S25360W18A	360	135.4	67.9	1800	120	2.66	1.53	0.048	1.642	57	553	250	RC3/8
S25360W20A	360	135.4	75.4	2000	133	2.66	1.53	0.048	1.642	57	553	250	RC3/8
S25400W15A	400	112.9	62.8	1500	100	3.54	2.05	0.145	2.557	64	596	290	RC3/8
S25400W18A	400	131.7	75.4	1800	120	3.04	1.75	0.053	1.879	64	596	290	RC3/8
S25400W20A	400	158	83.8	2000	133	2.53	1.46	0.037	1.305	64	596	290	RC3/8
S25440W15A	440	128.7	69.1	1500	100	3.42	1.97	0.059	2.115	72	596	290	RC3/8
S25440W18A	440	154.5	82.9	1800	120	2.85	1.64	0.04	1.469	72	596	290	RC3/8
S25440W20A	440	193.1	92.1	2000	133	2.28	1.32	0.026	0.94	72	596	290	RC3/8

Servo System Energy Saving Principle

Servo system oil circuit schematic

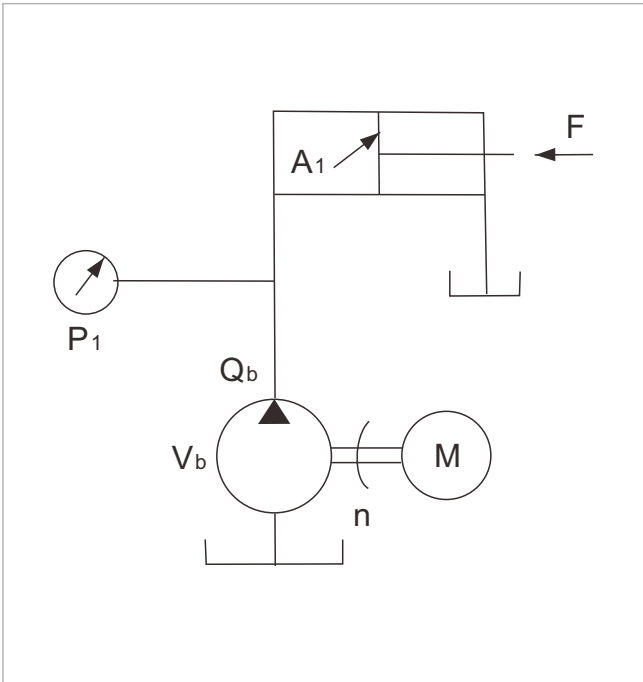

General system oil circuit schematic

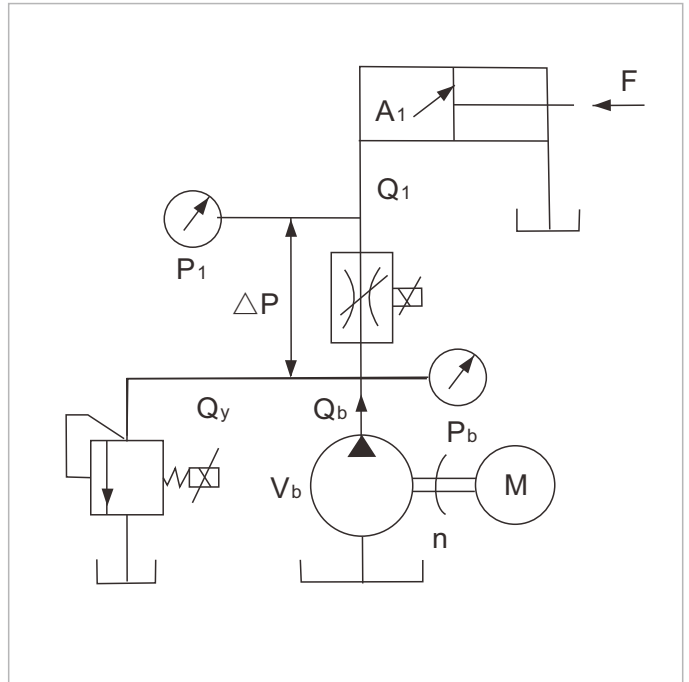

Energy loss graph

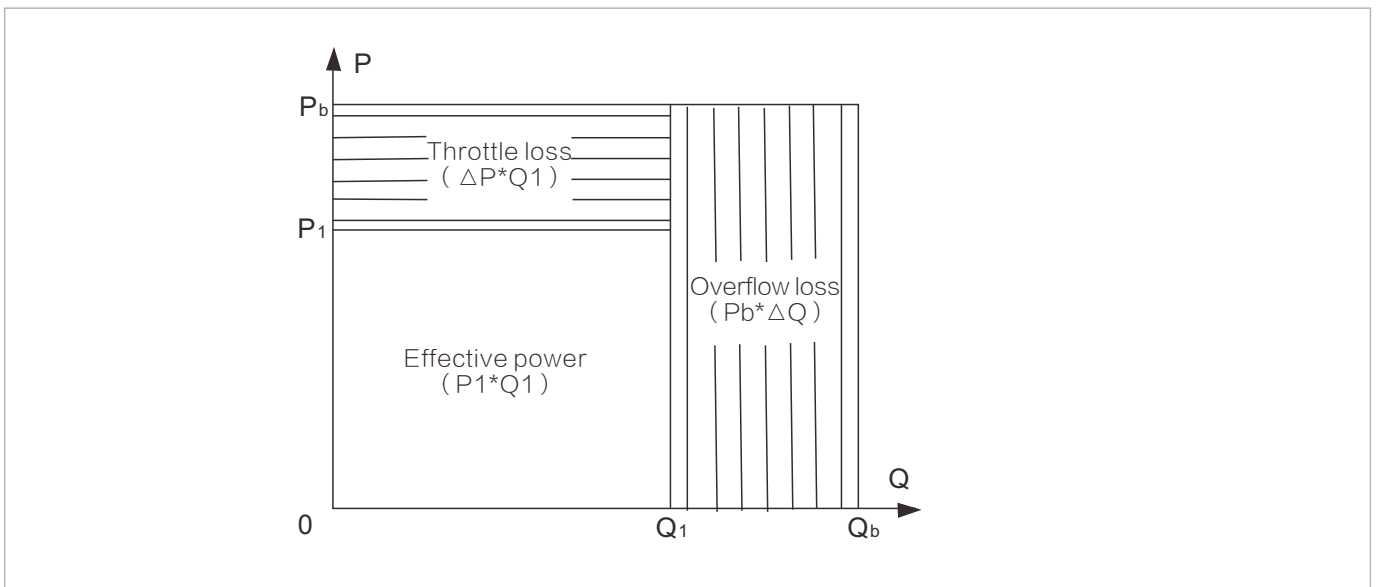

Servo System Selection

Required knowledge of selection – pump formula

The original pump displacement (q) × the original motor speed (n) = system flow (Q) = servo pump displacement (q) × servo pump maximum speed (n)

before selection
after selection

Under normal circumstances, select the pump of the following displacement and the speed is generally recommended not higher than 2000rpm:

31 cc; 40 cc; 50 cc; 63 cc; 80 cc; 125 cc; 160cc.

Servo pump maximum speed ≤ Motor rated speed × 130%

The servo motor maintains a constant torque at 130% of rated speed. When motor speed reaches 140% of the rated speed, the motor enters the constant power area and the torque decreases.

The rated motor speed includes: 1500rpm; 1700rpm; 2000rpm.

From the above information, we can determine the pump displacement and the rated speed of motor.
From the following information, we will calculate the motor torque and the driver power.

Required knowledge of selection – torque formula

The pump displacement (q) and the system pressure (P) determine the maximum torque (Tmax).

$$T_{max} = \Delta P \text{ (Mpa) } \times q \text{ (cm}^3 \text{) } \times 1.2 / (2\pi)$$

P is the pressure difference between the oil inlet and oil outlet, and the unit is Mpa, in this environment, it is equal to the system pressure as default; 1.2 coefficient stands for the efficiency loss from the hydraulic pump drive to the motor, including tubing expansion, friction, pump volumetric efficiency, transmission, bearing friction and other torque loss.

$$T_n = T_{max} \div a$$

A is the overload factor.

A value is generally floating between 0.9 and 1.5.

Injection molding machine is generally recommended to take 1.3-1.4.

Required knowledge of selection –current formula

Under normal circumstances, the larger the original motor load is, the smaller the value is.

$$I_{max} = T_{max} \div K_t$$

The value of Kt according to our application experience: in the current motor types, Kt is generally determined by the rated speed of motor. The values are as follows:

Rated speed

Kt of 1500rpm is about 3.29-3.37

Kt of 1700rpm is about 2.82-2.87

Kr of 2000rpm is about 2.37-2.60

Please check specific information from the motor parameter table.

I_{max} is the maximum current for the selected drive. After the maximum current is obtained, the drive power can be selected according to the following table.

Rated power (KW)	7.5	11	15	18.5	22	30	45	55
60s holding current (A)	26	38	48	57	68	90	112	165

Selection example

At present, there is a Haitian 380T injection molding machine, need to select the configuration servo.

Steps are as follows:

1. Check the original pump brand model: (Vickers 4535V 50A30 1DD 2R).
2. Check the original system pressure of the press is 140kgf.
3. Check the power of the original motor, speed (45kW 6 pole 970rpm).
4. Calculate the servo system pump, motor and drive.
 - 1) Look up the Vickers vane pump for the displacement: 162cc+97cc
 - 2) Get the flow (162cc+97cc) × 970rpm/1000=251L/min
 - 3) 251L/min=125ccservo pump × (1500 × 1.33) rpm
 - 4) $T_{max}=14\text{Mpa} \times 125\text{cc/rev} \times 1.2 \div 2\pi$
 $T_{max}=334\text{N} \cdot \text{m}$
 - 5) $T_n=334\text{N} \cdot \text{m} \div 1.3=256\text{N} \cdot \text{m}$ Select motor of **260N.m** rated torque
 - 6) $I_n=334\text{N} \cdot \text{m} \div 3.4=97\text{A}$ By looking up the table, we know that it requires **45kW** drive.
5. Select other accessories: such as pressure sensors, brackets, couplings, wire and so on.

Required knowledge of selection – original system

	Description	Unit
System pressure	The secure pressure when the original induction motor drives the original pump. The pressure is usually set in manufacturing factory; during operation, it does not exceed this pressure set in factory. Due to mechanical differences, there are differences in pressure.	(P) Kgf Mpa
System displacement	Within the unit time (per minute), the discharged liquid volume theoretically. The general formula is: $Q = q \times n$.	(Q) L/min
Pump displacement	The volume change when the pump main shaft rotates one circle.	(q) cc/rev
Asynchronous motor speed	The speed of asynchronous motor can achieve after start. As there is difference in motor poles, so the speed is also different: 4-pole motor = 1470rpm; 6-pole motor = 970rpm.	(n) Rpm
Asynchronous motor power	The rated power on motor nameplate	KW

Required knowledge of selection – servo system

	Description	Unit	Symbol	
Motor	Torque	The servo motor's continuous torque output of the secure range when it is under the control servo drive,	$\text{N} \cdot \text{m}$	T_n
	Rated speed	The value on the motor nameplate	rpm	ω_n
	Rated current	When the motor reaches the rated torque, the current passes through the motor winding	A	I_n
	Torque constant	The ratio of the rated torque to the rated current	$\text{N} \cdot \text{m/A}$	K_t
Drive	Rated power	The power consumption that the drive can afford	KW	
	Rated current	Rated current is generally 2 times of the rated power.	A	
Servo pump	Pump displacement	The size of the pump, used to calculate the torque and drive power		q
	Maximum speed	The maximum speed that the pump can withstand		
	Maximum pressure	The maximum pressure that the pump can withstand		

VEICHI

Shenzhen Veichi Electric Co., Ltd.

Block C, Wentao Science and Technology Park, Shiyan
Yingrenshi Community, Baoan District, Shenzhen, China
Tel: +86-0755-2968 5610 (EXT 835)
Fax: +86-755-2968 5615 E-mail: overseas@veichi.com
<http://www.veichi.org>

Suzhou Veichi Electric Co., Ltd.

No.1000 Songjia Road, Wuzhong Economic and Technological
Development Zone, Suzhou, China
Tel:+86-512-6617 1988
Fax:+86-512-6617 3610 Service hotline: 400-600-0303
<http://www.veichi.com>



*Version: March 2017 Edition
Shenzhen Veichi Electric Co., Ltd. all rights reserved,
subject to change without notice.