

# SD700 Series

## High-performance Servo System



**VEICHI**

Suzhou VEICHI Electric Co., Ltd

No.1000 Songjia Road, Guoxiang street, Wuzhong Economic and Technological Development Zone, Suzhou

Tel: +86-512-6617 1988 Fax: +86-512-6617 3610

Facebook: <https://www.facebook.com/veichigroup>

Whatsapp: +86- 138 2881 8903

<https://www.veichi.org/>



Official Website

\*Version:2023 V1.2

\*VEICHI Electric Co., Ltd all rights reserved, subject to change without notice.

# About us



Veichi (stock code: 688698) has always committed to electric drive and industrial control since its foundation. As an all-round company engaged in R & D, manufacturing and sales on high-tech industrial automation products, Veichi has been identified with several honorary titles such as Jiangsu provincial-level Enterprise Technology Center, Jiangsu Private-own Technical Enterprise, Specialized and sophisticated enterprises that produce new and unique products, Jiangsu Engineering Research Center, Jiangsu New and High-tech Enterprise and Suzhou city-level Gazelle Company (High Growth Enterprise) and has obtained the highest level of enterprise credit. Through years of independent research and development, Veichi now has authorized patents totaling 148 by the end of 12, 2022, and among them 36 are for invention. Having established R & D center and manufacturing bases in Suzhou, Shenzhen and Xi'an, added with the wholly-owned subsidiary in India, Veichi now are dealing with customers from several nations and regions and has the full capability to provide safe, competitive and trustworthy products and services to customers from the larger world.

Veichi provides various products including inverters from 0.4kW to 5,600kW, servo systems from 50W to 200kW, motion controllers, PLC and HMI, which are applied in all sorts of fields occasions like lifting, mining, rail traffic, machine tools, compressors, plastic equipment, photo-voltaic pumping, construction, robots/mechanical arms, printing and packaging, chemical fibers for textile use, metallurgy, municipal works, petrol work and chemical engineering. 20 service stations and 182 contracted distributors cover 31 provinces on China mainland and Hong Kong, Macao and Taiwan regions, which guarantees a massive and efficient network for sales and services for our customers. Veichi will continue to abide by the operation philosophy, that is, guided by market demand and driven by technical innovation, enlarge and enhance its core business like inverters, servo systems, control systems and SIOs. And Veichi will always be hard at providing quality products and services for customers and further make contributions to the development of electric drives and industrial controls.

## SD700 Series High-Performance Servo System

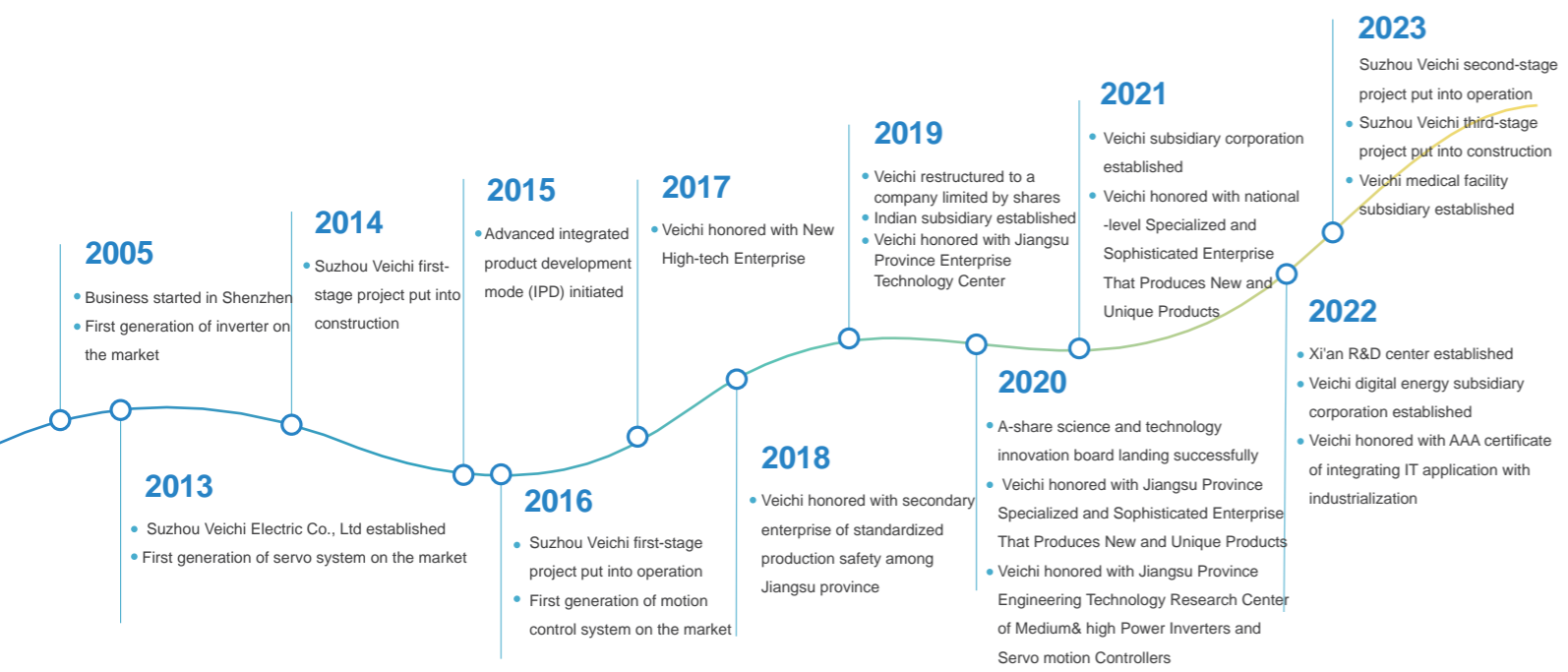

## Product features

### 3KHz speed loop response bandwidth

The unique current algorithm can effectively improve the speed loop bandwidth which can greatly reduce the adjusting time and improve production efficiency. The fastest adjusting time can reach 1ms.

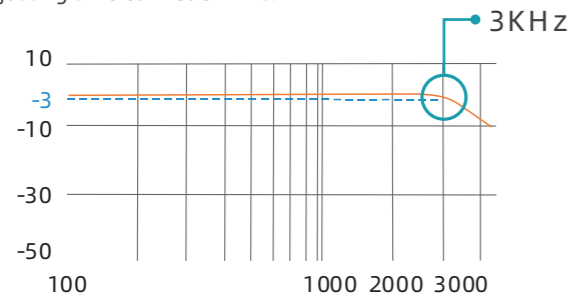

### Support full closed-loop mode

The full closed loop mode supports external second encoder or grating ruler to reduce mechanical transmission gaps and increase the actual positioning accuracy. (Supported by all the models)

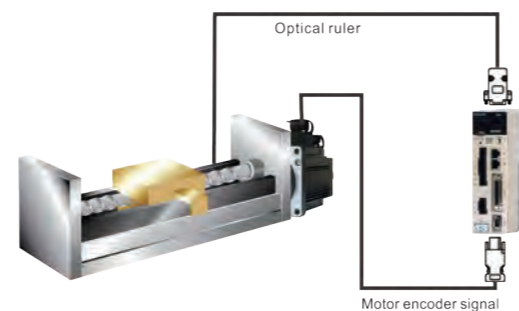

### 23-Bit absolute encoder

Pulses per turn reach up to 8388608 on a standard 23-bit multi-turn absolute encoder, communication speed up to 2.5Mpps and thus positioning is more accurate, low speed running is smoother, and loss of position caused by power failure will not be lost.

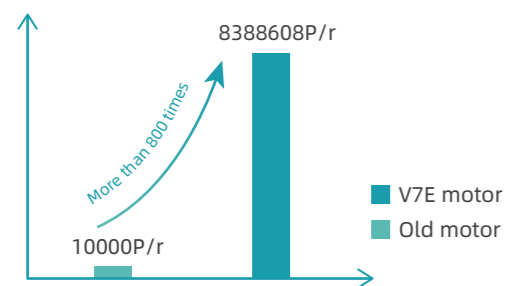

### Low frequency vibration suppression function

The vibration filter can be set via the PC software to effectively eliminate the inherent vibration frequency, greatly reducing axis jitter (sloshing) when it's stopped and effectively suppressing vibration within 0~100Hz. This function is often used to eliminate the end shaking when the injection molding manipulators and stacker are turned off.

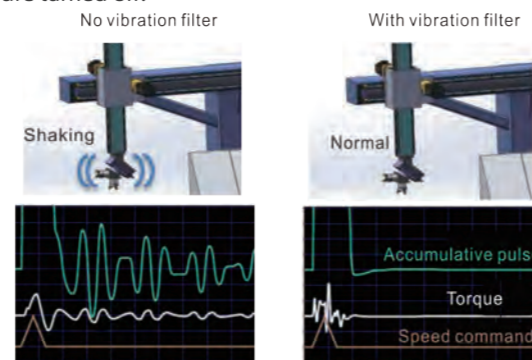

### Robust control

The latest method enables smooth operation without parameter adjustment even if the load rotational inertia changes within 30 times during motion. It's ready for use on installation and widely used on mechanical arms.

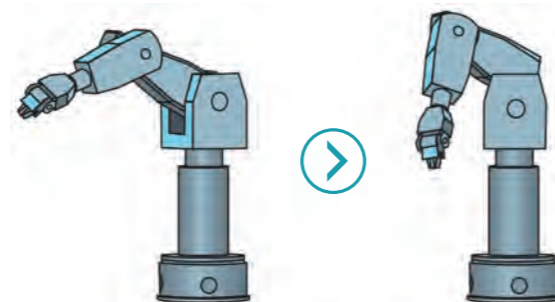

### Auto notch filter setting

It features easiness of use and the whole process is no longer than 70ms. Noise and vibration caused by mechanical resonance can be greatly reduced for faster response. It is widely used on machine tools.

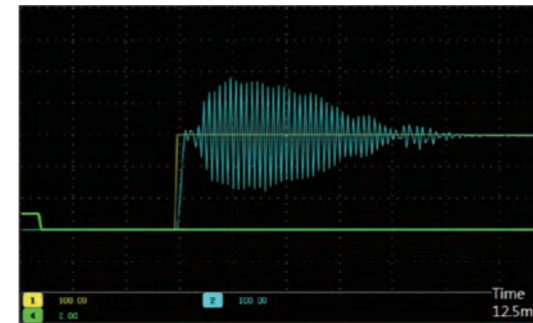

### Intelligent setting

Automatic gain adjustment, boot setting mode and sequential setting are all for using servo gain and it won't cost too much time and energy. More modes are available according to mechanical structures and processing properties to deliver best performance.

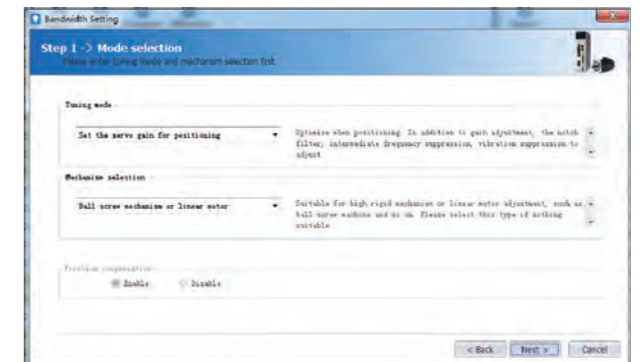

### Powerful bus communication function

Support RS-485, EtherCAT, CANopen, MECHATROLINK II, MECHATROLINKIII and other mainstream bus protocols.



### Significant reduction of motor pulsating torque, for more stable running at low speed

10-stage rotor and 12-slot stator, together with the special magnetic circuit, can effectively suppress the cogging and, greatly reduce torque pulsation, thus ensuring smoother motor operation at fixed speed and low speed.

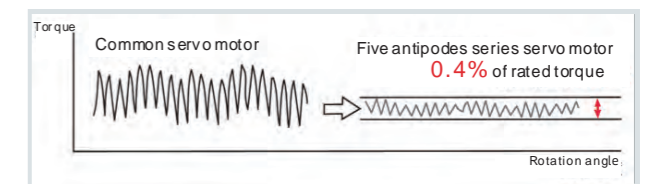

### Down-sized motor and uplifted dynamic performance

The latest manufacturing techniques are adopted here to optimize magnetic circuit and reduce magnetic loss, achieving motor high dynamic response; The motor length is shortened by about 2cm, and the temperature rise is reduced by 5 ~ 10°C to deliver higher shaft jump accuracy and easier wiring. All products in this series are designed with IP67 protection.



V7E motor



VM7 motor

If taking 400W as an example, the length is shortened by 20 mm.

Powerful PC software

No need to install any debugging software since connection between the drive and computer works via USB cord.



Batch parameter reading and writing

Inertia identification

PID parameters for different mechanical structures



Mechanical characteristics analysis, automatic resonance suppression

Internal position loop program JOG, easy to debug

The online oscilloscope monitoring real-time (125us) via multi-channels

Model description

SD 700 - 3R3 A - P A □

SD: Servo product code

700: High performance servo drive series

Rated current

	(A) 220VAC				(D) 400VAC							
1R8	1.8A	120	12A	3R8	3.8A	240	24A	700	70A	321	320A	
3R3	3.3A	160	16A	6R0	6.0A	300	30A	800	80A	421	420A	
5R5	5.5A			8R4	8.4A	400	40A	121	120A	521	520A	
7R6	7.6A			110	11A	500	50A	171	170A			
9R5	9.5A			170	17A	600	60A	221	220A			

Product management code  
Standard product default

Encoder type  
A: Absolute type  
B: Biss type

Drive type  
P: pulse type  
S: standard type  
C: CANopen bus type  
E: EtherCAT bus type  
M: MECHATROLINK II bus type  
L: MECHATROLINK III bus type  
N: PROFINET bus type  
F: Multi IO interface type

Rated voltage  
A: 220VAC  
D: 400VAC

Code	Model	Pulse input	16 bit analog	Full closed loop	RS485	CANopen	EtherCAT	MECHATRO LINK II	MECHATRO LINK III	PROFINET
P	Pulse type	√	0	√	√	×	×	×	×	×
S	Standard type	√	√	√	√	√	×	×	×	×
C	CANopen type	√	0	×	√	√	×	×	×	×
E	EtherCAT type	×	×	×	√	×	√	×	×	×
M	MECHATROLINK II type	×	×	×	√	×	×	√	×	×
L	MECHATROLINK III type	×	×	×	√	×	×	×	√	×
N	PROFINET type	×	×	×	√	×	×	×	×	√

0 support 12 bit analog    √ standard configured    △ optional    × not configured

Drive power & Case volume

Model	Input	Output		Case volume
	Rated voltage (V)	Rated current (A)	Instantaneous current (A)	
SD700-1R8A	Single phase 220	1.8	6.3	A
SD700-3R3A	Single phase 220	3.3	11.6	
SD700-5R5A	Single / three phase 220	5.5	16.5	B
SD700-7R6A	Single / three phase 220	7.6	22.8	
SD700-9R5A	Three phase 220	9.5	23.8	C
SD700-120A	Three phase 220	12.0	36.0	
SD700-160A	Three phase 220	16.0	40.0	B
SD700-3R8D	Three phase 400	3.8	11.4	
SD700-6R0D	Three phase 400	6.0	18.0	C
SD700-8R4D	Three phase 400	8.4	25.2	
SD700-110D	Three phase 400	11.0	27.5	D
SD700-170D	Three phase 400	17.0	42.5	
SD700-240D	Three phase 400	24.0	60.0	E
SD700-300D	Three phase 400	30.0	70.0	
SD700-400D	Three phase 400	40.0	80.0	F
SD700-500D	Three phase 400	50.0	115.0	
SD700-600D	Three phase 400	60.0	120.0	G
SD700-700D	Three phase 400	70.0	140.0	
SD700-800D	Three phase 400	80.0	160.0	H
SD700-121D	Three phase 400	120.0	240.0	
SD700-171D	Three phase 400	170.0	340.0	I
SD700-221D	Three phase 400	220.0	440.0	
SD700-321D	Three phase 400	320.0	640.0	J
SD700-421D	Three phase 400	420.0	840.0	
SD700-521D	Three phase 400	520.0	1040.0	L

Drive appearance & Installation dimension

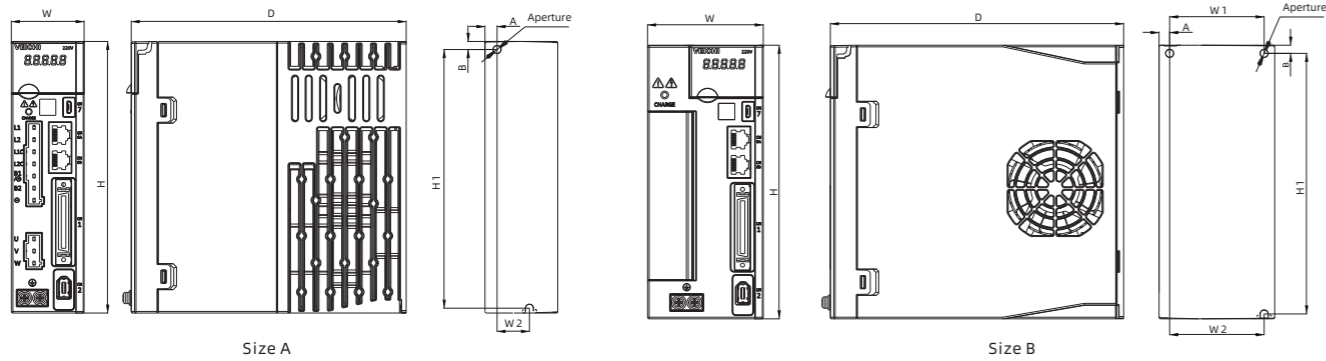

Chassis size	Model	Overall dimension(mm)			Installation dimension (mm)						Mounting hole size
		W	H	D	W1	W2	H1	H2	A	B	
A	SD700-1R8A-**-	45	168	170	\	20	160	\	7.5	5	2-M4
	SD700-3R3A-**-										
B	SD700-5R5A-**-	71	168	180	58	58	160	\	6.5	5	3-M4
	SD700-7R6A-**-										
	SD700-9R5A-**-										
	SD700-2R5D-**-										
	SD700-3R8D-**-										

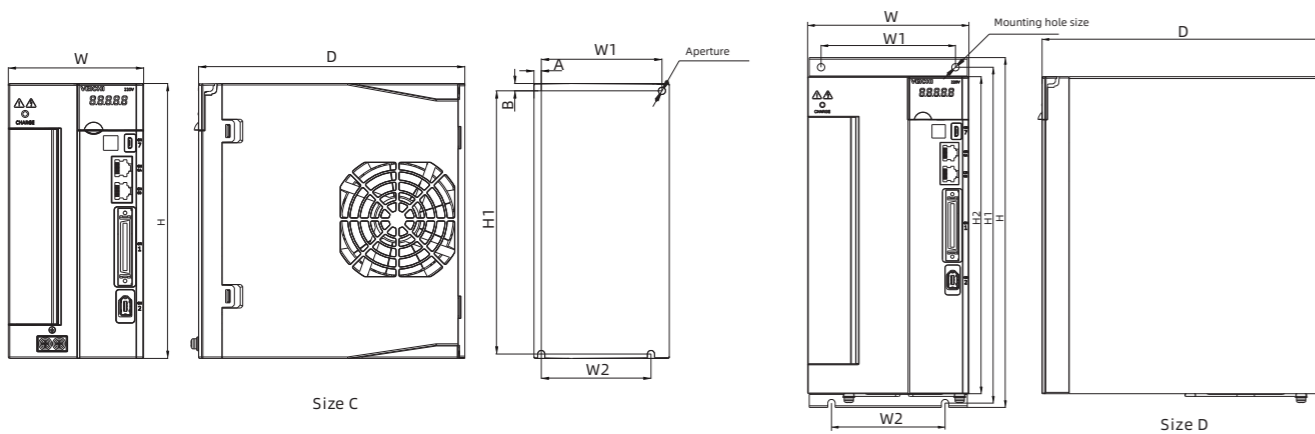

Chassis size	Model	Overall dimension(mm)			Installation dimension (mm)						Mounting hole size
		W	H	D	W1	W2	H1	H2	A	B	
C	SD700-120A-**-	92.5	188	182	82.5	75	180	\	5	5	3-M4
	SD700-160A-**-										
	SD700-6R0D-**-										
	SD700-8R4D-**-										
D	SD700-110D-**-	120	260	210	100	84.5	250	236	\	\	4-M5
	SD700-170D-**-										
	SD700-240D-**-										
	SD700-300D-**-										

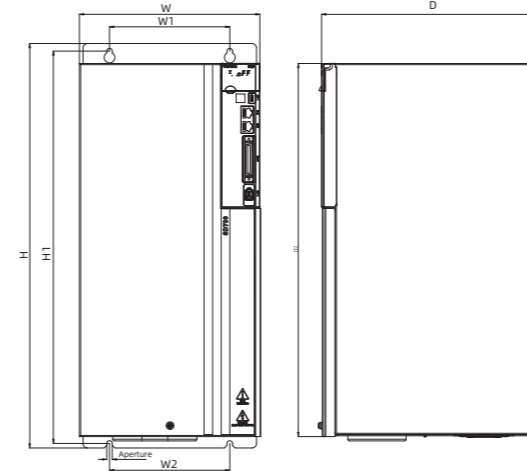

Chassis size	Model	Overall dimension(mm)			Installation dimension (mm)						Aperture
		W	H	D	W1	W2	H1	H2	A	B	
E	SD700-400D-**-	180	413	240	125	125	404.5	413	\	\	4-M6
F	SD700-500D-**-	210	471	254	140	140	457	434.5	\	\	4-M6
	SD700-600D-**-										
G	SD700-700D-**-	240	558	310	176	176	544	520	\	\	4-M6
	SD700-800D-**-										
	SD700-121D-**-										
H	SD700-171D-**-	270	638	350	195	195	615	580	\	\	4-M10
I	SD700-221D-**-	350	738	405	220	220	715	680	\	\	4-M10
J	SD700-321D-**-	360	940	495	200	200	911	880	\	\	4-M18
K	SD700-421D-**-	370	1140	565	200	200	1111	1080	\	\	4-M18
L	SD700-521D-**-	420	1250	590	240	240	1213	1180	\	\	4-M20

Drive specifications

Items		Specifications	
Control mode		IGBT PWM control; sine wave current drive mode	
Feedback	Rotating motor combination	Serial Communication Type Encoder: 17-bit, 23-bit absolute encoder	
Environmental condition	Ambient temperature	-5°C ~ 55°C(derating use at 55°C ~ 60°C)	
	Storage temperature	-20°C ~ 85°C	
	Ambient humidity	Below 95%RH (no freezing, no condensation)	
	Storage humidity	Below 95%RH (no freezing, no condensation)	
	Vibration resistance	4.9m/s <sup>2</sup>	
	Impact resistance	19.6m/s <sup>2</sup>	
	Protection class	IP20	
	Cleanliness	No corrosive gases or flammable gases No water, oil or chemicals	
	Altitude	Environment with less dust, ash, salt, and metal powders Below 1000m (derating use at 1000m to 2000m)	
	Others	No static interference, strong electric field, strong magnetic sound, radiation and so on	
Applicable standard		EN 61800-5-1:2007      EN 61800-3:2004/A1:2012	
Installation type		Base mounting type: all models	
Performance	Speed control range	1: 6000 (the lower limit of speed control range is the value under the condition of not stop with rated torque load)	
	Speed fluctuation rate	Load fluctuation	The lower limit of speed control also means the requirement not to stop when operation at rated torque with loads
		Voltage fluctuation	Rated speed 0% (rated voltage±10%)
		Temperature fluctuation	Below rated speed ±0.1% (temperature fluctuation:25±25°C)
	Torque control accuracy	±1%	
Soft start time setting		0~30s (acceleration and deceleration can be set separately)	
Communication function	Host communication	Communication mode	RS485、CANOpen、EtherCAT、MECHATROLINK-II、MECHATROLINK-III、PROFINET
		Axis address setting	Parameters setting
	USB communication	Equipment connection	Computer
			According to USB1.1 specifications(12M)
Display function			CHARGE indicator light
Keypad operator function			Button switch ×4

Items		Specifications		
Input/output signal	Encoder pulse output of frequency division	A phase, B phase, C phase: number of pulse frequency-division output for linear drive can be arbitrarily set		
	Sequential control input signal	Working voltage range: DC24V±20% Input points:9 Input mode: common collector input, common emitter input Input signal Servo ON (/S-ON) P action/P-CON Origin reset deceleration switch signal (/DEC) Forward drive banned (P-OT), reverse drive banned (N-OT) Alarm reset (/ALM-RST) Torque limit selection (/TLC) Speed rotation direction selection signal (/SPD-D) Internal speed setting selection (/SPD-A, /SPD-B) Control mode switch (/C-SEL) Zero position fixed (/ZCLAMP) Command pulse inhibited (/INHIBIT) Magnetic poles detection input (/P-DET) signal Gain switch (/G-SEL) Command pulse input rate switch (/PSEL) Assignable output signals and positive / negative logic switch		
Input/output signal	Fixed output	Working voltage range: DC5V-DC30V Output points:1 Output signal:servo alarm (ALM)		
	Sequential control output signal	Working voltage range: DC5V-DC30V Output points:3 Input method: optocoupler output (isolated) Output signal Position finished(/COIN) Rotational detection (/TGON) Servo ready( S-RDY) Torque limited detection (/CLT) Speed limit detection (/VLT) Brake (/BK) Warning (/WARN) Location nearby (/NEAR) Assignable output signals and change positive / negative logic		
Dynamic brake		Operate when the main power OFF, servo alarm, servo OFF, Over travel(OT) (only for AC220V A,B model)		
Regeneration treatment		Built-in function, see "Brake resistance selection"		
Over travel (OT) prevention		Dynamic brake (DB) stop, DEC stop, or free stop when P-OT, N-OT inputs operate		
Protection function		Over current, over voltage, under voltage, overload, regeneration fault, etc		
Auxiliary function		Gain adjustment, alarm record, JOG operation, origin search, etc		
Control	Position control	Feedforward compensation	0% ~ 100%	
		Position arrived range	0~1073741824 Command unit	
	Input signal	Command pulse	command pulse pattern	Choose one of the following
			Input pattern	Symbol + pulse sequence, CW+CCW pulse sequence,two-phase pulse of 90°difference
		Maximum input frequency	linear	Symbol + pulse sequence, CW+CCW pulse sequence: 4Mpps
			Open collector	Two-phase pulse of 90°difference: 1Mpps
Input rate switching	linear	Symbol + pulse sequence, CW+CCW pulse sequence: 200Kpps		
	Open collector	Two-phase pulse of 90°difference: 200Kpps		
signal clearance		1~100 times		
Clearance of position deviation		Clearance of position deviation		

Items		Specifications		
Control	speed control	Soft start time setting	0 ~ 30s(set acceleration and deceleration respectively)	
		Input signal	Command voltage	Maximum input voltage: ±10V (motor runs forwardly under positive voltage command)
			Rated speed at DC6V [factory setting]	
			Variable input gain setting	
		Input impedance	About 14KΩ	
	Internal set speed control	Loop time parameter	30μs	
		Rotation direction selection	Inner speed set selection (/SPD-A, /SDP-B)	
	Torque control	Input signal	Speed selection	Rotary direction selection (/SPD-D)
			Stop or change to other control modes when both sides are OFF	
			Command voltage	Maximum input voltage: ±10V (motor runs forwardly under positive voltage command)
Rated torque at DC3V [factory setting]				
Variable input gain setting				
Input impedance	About 14KΩ			
Loop time setting	16μs			

### System configuration drawing

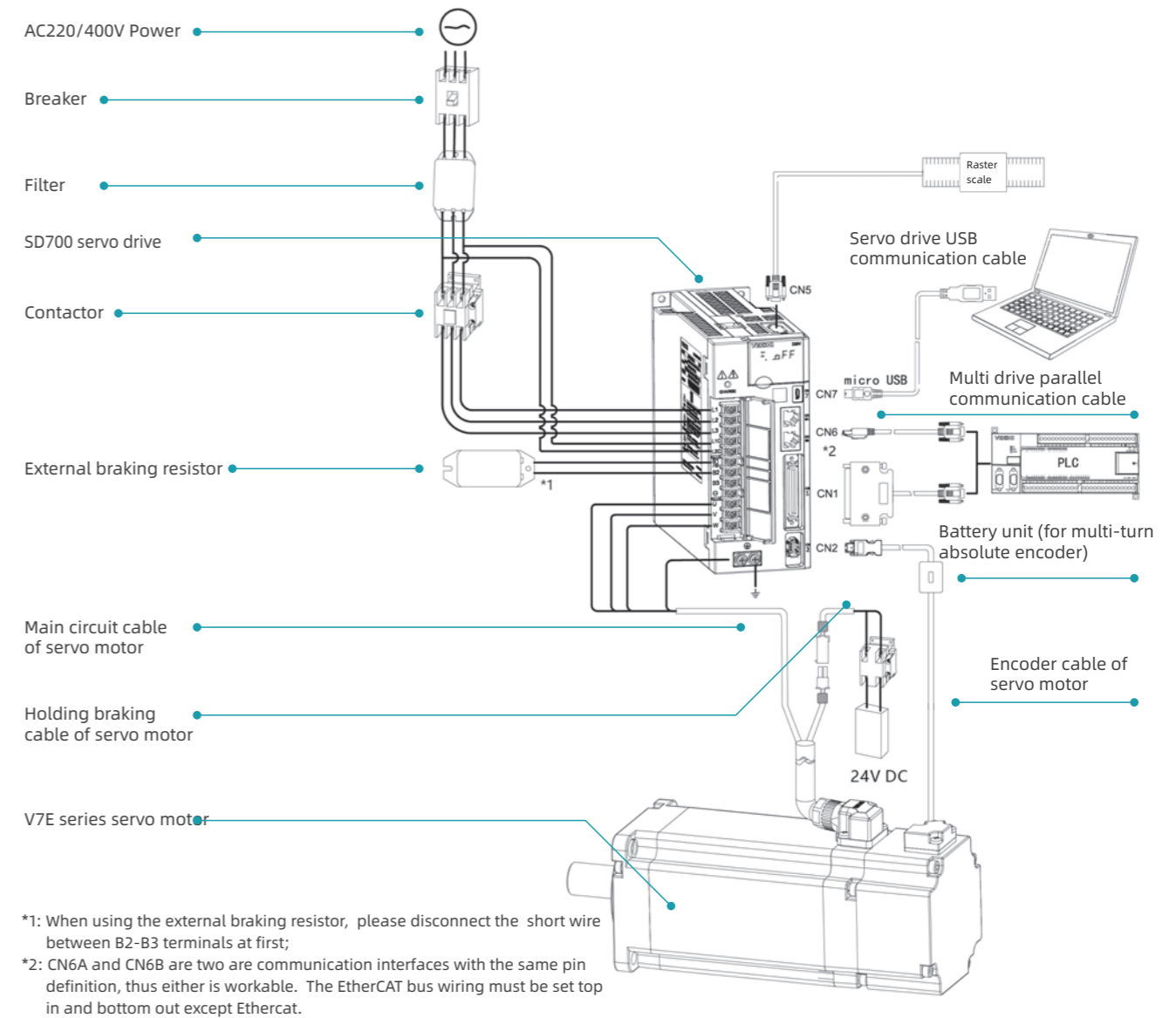

Standard wiring diagram - position mode

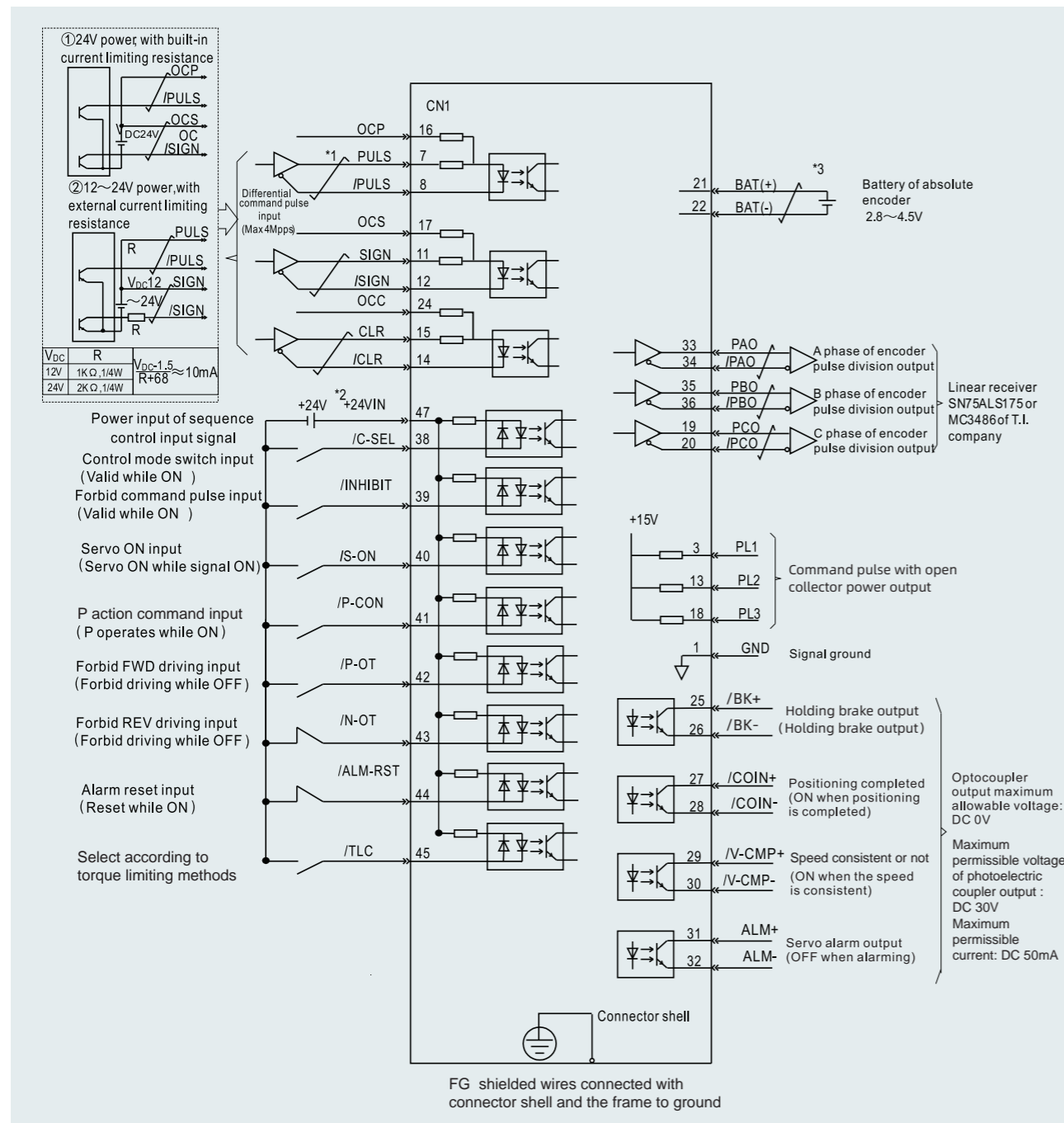

- \*1.  $\text{---}$  is the twisted shields.
  - \*2. DC24V power should be prepared by user. Double insulation or reinforced insulation equipments should be used for DC24V power.
  - \*3. Connected while using absolute encoder. But never connect with CN1-21, CN1-22 pins while using encoder cables with battery unit
  - \*4. Output signal should be received by linear receiver.
- (Note) While using 24V braker, DC24V power should be separated from the power for input and output signal (CN1). Please prepare other power individually, otherwise, there may be misoperation of input and output signal while power on.

Standard wiring diagram - speed / torque mode

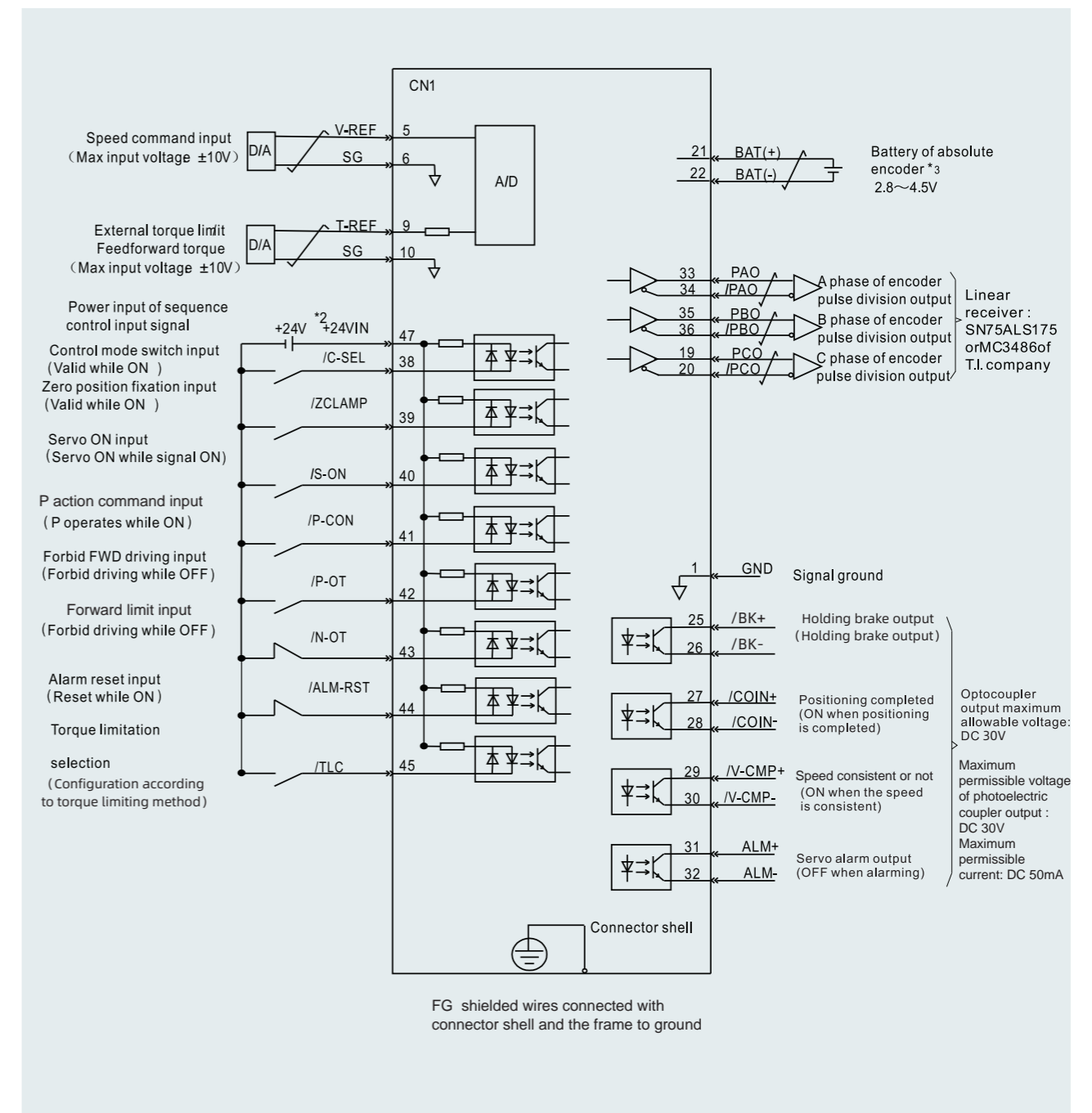

- \*1.  $\text{---}$  is the twisted shields.
  - \*2. DC24V power should be prepared by user. Double insulation or reinforced insulation equipments should be used for DC24V power.
  - \*3. Connected while using absolute encoder. But never connect with CN1-21, CN1-22 pins while using encoder cables with battery unit
  - \*4. Output signal should be received by linear receiver.
- (Note) While using 24V braker, DC24V power should be separated from the power for input and output signal (CN1). Please prepare other power individually, otherwise, there may be misoperation of input and output signal while power on.

### Servo motor model description

V7E - L 06 A - R40 30 - D 1 □

Product series

V7E

VM7

Inertia level

L: low inertia

M: medium inertia

H: high inertia

Flange

04:40mm 18:180mm

06:60mm 20:200mm

08:80mm 26:260mm

11:110mm 32:320mm

13:130mm 40:400mm

Rated voltage

A: 220V AC

D: 400V AC

Rated power

Mark	Power	Mark	Power	Mark	Power	Mark	Power
R05	50W	1R2	1.2KW	4R4	4.4KW	037	37KW
R10	100W	1R3	1.3KW	5R5	5.5KW	045	45KW
R20	200W	1R5	1.5KW	7R5	7.5KW	055	55KW
R40	400W	1R8	1.8KW	011	11KW	075	75KW
R60	600W	2R0	2.0KW	015	15KW	090	90KW
R75	750W	2R3	2.3KW	020	20KW	110	110KW
R85	850W	2R9	2.9KW	022	22KW	150	150KW
1R0	1.0KW	3R0	3.0KW	030	30KW	200	200KW

Factory management code

Mark	Axis		Oil seal		Brake	
	light axis	key axis	Yes	No	Yes	No
1		•	•			•
2		•	•		•	

Encoder type

D: 23 bit multi-turn absolute optical encoder

Q: 17 bit single-turn absolute magnetic encoder

R: 17 bit multi-turn absolute magnetic encoder

S: 20 bit multi-turn absolute optical cross shaft encoder

Rated speed (RPM)

15:1500

20:2000

25:2500

30:3000

Motor braking power chart (Estimated) :

Flange	Braking power
40	7W
60	10W
80	15W
110	15W
130	20W
180	30W



### Servo motor specifications (General model)

V7E model	Voltage (V)	Power (W)	Rated torque (N·m)	Rated speed (RPM)	Max speed (RPM)	Rated current (A)	Max current (A)	Moment of inertia
V7E-L04A-R1030-□1	220	100	0.32	3000	6000	1	3	0.051kg·cm <sup>2</sup>
V7E-L04A-R1030-□2	220	100	0.32	3000	6000	1	3	0.052kg·cm <sup>2</sup>
V7E-L06A-R2030-□1	220	200	0.64	3000	6000	1.7	5.1	0.18kg·cm <sup>2</sup>
V7E-L06A-R2030-□2	220	200	0.64	3000	6000	1.7	5.1	0.2kg·cm <sup>2</sup>
V7E-L06A-R4030-□1	220	400	1.27	3000	6000	2.6	7.8	0.34kg·cm <sup>2</sup>
V7E-L06A-R4030-□2	220	400	1.27	3000	6000	2.6	7.8	0.36kg·cm <sup>2</sup>
V7E-M06A-R4030-□1	220	400	1.27	3000	6000	2.6	7.8	0.67kg·cm <sup>2</sup>
V7E-M06A-R4030-□2	220	400	1.27	3000	6000	2.6	7.8	0.69kg·cm <sup>2</sup>
V7E-L06A-R6030-□1	220	600	1.91	3000	5000	3.3	9.9	0.51kg·cm <sup>2</sup>
V7E-L06A-R6030-□2	220	600	1.91	3000	5000	3.3	9.9	0.53kg·cm <sup>2</sup>
V7E-L08A-R7530-□1	220	750	2.38	3000	6000	4.6	13.8	1.02kg·cm <sup>2</sup>
V7E-L08A-R7530-□2	220	750	2.38	3000	6000	4.6	13.8	1.13kg·cm <sup>2</sup>
V7E-M08A-R7530-□1	220	750	2.38	3000	6000	4.6	13.8	2.3kg·cm <sup>2</sup>
V7E-M08A-R7530-□2	220	750	2.38	3000	6000	4.6	13.8	2.41kg·cm <sup>2</sup>
V7E-L08A-1R030-□1	220	1000	3.18	3000	5000	5	16.5	1.34kg·cm <sup>2</sup>
V7E-L08A-1R030-□2	220	1000	3.18	3000	5000	5	16.5	1.45kg·cm <sup>2</sup>
V7E-M11A-1R230-□1	220	1200	3.82	3000	5000	6.3	18.9	4.91kg·cm <sup>2</sup>
V7E-M11A-1R230-□2	220	1200	3.82	3000	5000	6.3	18.9	5.52kg·cm <sup>2</sup>
V7E-M11A-1R530-□1	220	1500	4.78	3000	5000	7.6	22.8	6.1kg·cm <sup>2</sup>
V7E-M11A-1R530-□2	220	1500	4.78	3000	5000	7.6	22.8	6.71kg·cm <sup>2</sup>
V7E-M11A-1R830-□1	220	1800	5.73	3000	5000	9.3	27.9	7.28kg·cm <sup>2</sup>
V7E-M11A-1R830-□2	220	1800	5.73	3000	5000	9.3	27.9	7.89kg·cm <sup>2</sup>
V7E-M13A-1R020-□1	220	1000	4.78	2000	3000	4.9	14.7	12.98kg·cm <sup>2</sup>
V7E-M13A-1R020-□2	220	1000	4.78	2000	3000	4.9	14.7	15.12kg·cm <sup>2</sup>
V7E-M13A-1R520-□1	220	1500	7.16	2000	3000	7.1	21.3	18.38kg·cm <sup>2</sup>
V7E-M13A-1R520-□2	220	1500	7.16	2000	3000	7.1	21.3	20.52kg·cm <sup>2</sup>
V7E-M13A-2R020-□1	220	2000	9.55	2000	3000	9.4	28.2	25.58kg·cm <sup>2</sup>
V7E-M13A-2R020-□2	220	2000	9.55	2000	3000	9.4	28.2	27.72kg·cm <sup>2</sup>
V7E-M13A-3R020-□1	220	3000	14.33	2000	3000	14	42	36.38kg·cm <sup>2</sup>
V7E-M13A-3R020-□2	220	3000	14.33	2000	3000	14	42	38.52kg·cm <sup>2</sup>
V7E-M18A-2R915-□1	220	2900	18.46	1500	2000	12	30	49.56kg·cm <sup>2</sup>
V7E-M18A-2R915-□2	220	2900	18.46	1500	2000	12	30	56.05kg·cm <sup>2</sup>
V7E-M18A-4R415-□1	220	4400	28.01	1500	1800	16	40	68.9kg·cm <sup>2</sup>
V7E-M18A-4R415-□2	220	4400	28.01	1500	1800	16	40	75.39kg·cm <sup>2</sup>
V7E-M13D-1R020-□1	380	1000	4.78	2000	3000	3.2	9.6	12.98kg·cm <sup>2</sup>
V7E-M13D-1R020-□2	380	1000	4.78	2000	3000	3.2	9.6	15.12kg·cm <sup>2</sup>
V7E-M13D-1R520-□1	380	1500	7.16	2000	3000	4.4	13.2	18.38kg·cm <sup>2</sup>
V7E-M13D-1R520-□2	380	1500	7.16	2000	3000	4.4	13.2	20.52kg·cm <sup>2</sup>
V7E-M13D-2R020-□1	380	2000	9.55	2000	3000	5.5	16.5	25.58kg·cm <sup>2</sup>
V7E-M13D-2R020-□2	380	2000	9.55	2000	3000	5.5	16.5	27.72kg·cm <sup>2</sup>
V7E-M13D-3R020-□1	380	3000	14.33	2000	3000	8.3	24.9	36.38kg·cm <sup>2</sup>
V7E-M13D-3R020-□2	380	3000	14.33	2000	3000	8.3	24.9	38.52kg·cm <sup>2</sup>
V7E-M18D-2R915-□1	380	2900	18.46	1500	2000	7.1	17.8	49.56kg·cm <sup>2</sup>
V7E-M18D-2R915-□2	380	2900	18.46	1500	2000	7.1	17.8	56.05kg·cm <sup>2</sup>



### Servo motor specifications (General model)

V7E model	Voltage (V)	Power (W)	Rated torque (N·m)	Rated speed (RPM)	Max speed (RPM)	Rated current (A)	Max current (A)	Moment of inertia
V7E-M18D-4R415-□1	380	4400	28.01	1500	2000	10.9	27.3	68.9kg·cm <sup>2</sup>
V7E-M18D-4R415-□2	380	4400	28.01	1500	2000	10.9	27.3	75.39kg·cm <sup>2</sup>
V7E-M18D-5R515-□1	380	5500	35.02	1500	2000	13.4	33.5	110.11kg·cm <sup>2</sup>
V7E-M18D-5R515-□2	380	5500	35.02	1500	2000	13.4	33.5	116.6kg·cm <sup>2</sup>
V7E-M18D-7R515-□1	380	7500	47.75	1500	2000	17	42.5	156.61kg·cm <sup>2</sup>
V7E-M18D-7R515-□2	380	7500	47.75	1500	2000	17	42.5	163.09kg·cm <sup>2</sup>

### Servo motor specifications (Purposed model)

V7E model	Voltage (V)	Power (W)	Rated torque (N·m)	Rated speed (RPM)	Max speed (RPM)	Rated current (A)	Max current (A)	Moment of inertia
V7E-L08A-R7520-□1L	220	750	3.58	2000	2500	2.8	8.4	1.34kg·cm <sup>2</sup>
V7E-L08A-R7520-□2L	220	750	3.58	2000	2500	2.8	8.4	1.45kg·cm <sup>2</sup>
V7E-L08A-R7530-□1L	220	750	2.38	3000	4000	3.1	9.3	1.02kg·cm <sup>2</sup>
V7E-L08A-R7530-□2L	220	750	2.38	3000	4000	3.1	9.3	1.13kg·cm <sup>2</sup>
V7E-M13A-R8515-□1	220	850	5.41	1500	3000	5.4	16.2	12.98kg·cm <sup>2</sup>
V7E-M13A-R8515-□2	220	850	5.41	1500	3000	5.4	16.2	15.12kg·cm <sup>2</sup>
V7E-M13A-R8515-□1B	220	850	5.41	1500	3000	5.4	16.2	12.98kg·cm <sup>2</sup>
V7E-M13A-R8515-□2B	220	850	5.41	1500	3000	5.4	16.2	15.12kg·cm <sup>2</sup>
V7E-M13A-1R815-□1	220	1800	11.46	1500	3000	10.9	32.7	25.85kg·cm <sup>2</sup>
V7E-M13A-1R815-□2	220	1800	11.46	1500	3000	10.9	32.7	27.72kg·cm <sup>2</sup>
V7E-M13A-1R815-□1B	220	1800	11.46	1500	3000	10.9	32.7	25.58kg·cm <sup>2</sup>
V7E-M13A-1R815-□2B	220	1800	11.46	1500	3000	10.9	32.7	27.72kg·cm <sup>2</sup>
V7E-M13A-1R315-□1	220	1300	8.28	1500	3000	8.2	24.6	18.38kg·cm <sup>2</sup>
V7E-M13A-1R315-□2	220	1300	8.28	1500	3000	8.2	24.6	20.52kg·cm <sup>2</sup>
V7E-M13A-2R315-□1	220	2300	14.64	1500	3000	14	42	36.38kg·cm <sup>2</sup>
V7E-M13A-2R315-□2	220	2300	14.64	1500	3000	14	42	38.52kg·cm <sup>2</sup>
V7E-M13A-2R315-□1L	220	2300	14.64	1500	2000	9.5	28.5	36.38kg·cm <sup>2</sup>
V7E-M13A-2R315-□2L	220	2300	14.64	1500	2000	9.5	28.5	38.52kg·cm <sup>2</sup>
V7E-M18A-2R915-□1H	220	2900	18.46	1500	3000	16	40	49.56kg·cm <sup>2</sup>
V7E-M18A-2R915-□2H	220	2900	18.46	1500	3000	16	40	56.05kg·cm <sup>2</sup>
V7E-M13D-R8515-□1B	380	850	5.41	1500	3000	3.3	9.9	12.98kg·cm <sup>2</sup>
V7E-M13D-R8515-□2B	380	850	5.41	1500	3000	3.3	9.9	15.12kg·cm <sup>2</sup>
V7E-M13D-R8515-□1	380	850	5.41	1500	3000	3.3	9.9	12.98kg·cm <sup>2</sup>
V7E-M13D-R8515-□2	380	850	5.41	1500	3000	3.3	9.9	15.12kg·cm <sup>2</sup>
V7E-M13D-1R315-□1	380	1300	8.28	1500	3000	4.8	14.4	18.38kg·cm <sup>2</sup>
V7E-M13D-1R315-□2	380	1300	8.28	1500	3000	4.8	14.4	20.52kg·cm <sup>2</sup>
V7E-M13D-1R815-□1B	380	1800	11.46	1500	3000	6.6	19.8	25.58kg·cm <sup>2</sup>
V7E-M13D-1R815-□2B	380	1800	11.46	1500	3000	6.6	19.8	27.72kg·cm <sup>2</sup>
V7E-M13D-1R815-□1	380	1800	11.46	1500	3000	6.6	19.8	25.58kg·cm <sup>2</sup>
V7E-M13D-1R815-□2	380	1800	11.46	1500	3000	6.6	19.8	27.72kg·cm <sup>2</sup>

### Servo motor specifications (Purposed model)

V7E model	Voltage (V)	Power (W)	Rated torque (N·m)	Rated speed (RPM)	Max speed (RPM)	Rated current (A)	Max current (A)	Moment of inertia
V7E-M13D-2R315-□1L	380	2300	14.64	1500	2000	5.6	16.8	36.38kg·cm <sup>2</sup>
V7E-M13D-2R315-□2L	380	2300	14.64	1500	2000	5.6	16.8	38.52kg·cm <sup>2</sup>
V7E-M13D-2R315-□1	380	2300	14.64	1500	3000	8.4	25.2	36.38kg·cm <sup>2</sup>
V7E-M13D-2R315-□2	380	2300	14.64	1500	3000	8.4	25.2	38.52kg·cm <sup>2</sup>
V7E-M18D-2R915-□1H	380	2900	18.46	1500	3000	10.7	26.8	49.56kg·cm <sup>2</sup>
V7E-M18D-2R915-□2H	380	2900	18.46	1500	3000	10.7	26.8	56.05kg·cm <sup>2</sup>
V7E-M18D-4R415-□1H	380	4400	28.01	1500	3000	16.2	40.5	68.9kg·cm <sup>2</sup>
V7E-M18D-4R415-□2H	380	4400	28.01	1500	3000	16.2	40.5	75.39kg·cm <sup>2</sup>
V7E-M18D-5R515-□1H	380	5500	35.02	1500	3000	19	47.5	110.11kg·cm <sup>2</sup>
V7E-M18D-5R515-□2H	380	5500	35.02	1500	3000	19	47.5	116.6kg·cm <sup>2</sup>
V7E-M18D-5R515-□1BH	380	5500	35.02	1500	3000	19	47.5	110.11kg·cm <sup>2</sup>
V7E-M18D-5R515-□2BH	380	5500	35.02	1500	3000	19	47.5	116.6kg·cm <sup>2</sup>
V7E-M18D-7R515-□1H	380	7500	47.75	1500	3000	27.6	69	156.6kg·cm <sup>2</sup>
V7E-M18D-7R515-□2H	380	7500	47.75	1500	3000	27.6	69	163.09kg·cm <sup>2</sup>
V7E-M18D-7R515-□1BH	380	7500	47.75	1500	3000	27.6	69	156.6kg·cm <sup>2</sup>
V7E-M18D-7R515-□2BH	380	7500	47.75	1500	3000	27.6	69	163.09kg·cm <sup>2</sup>

### Servo motor specifications (big power)

V7E model	Voltage (V)	Power	Rated torque (N·m)	Rated speed (RPM)	Max speed (RPM)	Rated current (A)	Max current (A)	Moment of inertia
VM7-M20D-01115-D1FNS	380	11000	70	1500	2000	21	42	70kg·cm <sup>2</sup>
VM7-M20D-01115-D2FN	380	11000	70	1500	2000	21	42	80kg·cm <sup>2</sup>
VM7-M20D-01515-D1FNS	380	15000	96	1500	2000	29	58	100kg·cm <sup>2</sup>
VM7-M20D-01515-D2FN	380	15000	96	1500	2000	29	58	110kg·cm <sup>2</sup>
VM7-M20D-02015-D1FN	380	20000	127	1500	2000	38.5	77	147kg·cm <sup>2</sup>
VM7-M20D-02015-D2FN	380	20000	127	1500	2000	38.5	77	157kg·cm <sup>2</sup>
VM7-M20D-02215-D1FN	380	22000	140	1500	2000	42	84	171kg·cm <sup>2</sup>
VM7-M20D-02215-D2FN	380	22000	140	1500	2000	42	84	180kg·cm <sup>2</sup>
VM7-M26D-03015-D1FN	380	30000	191	1500	2000	58	116	372kg·cm <sup>2</sup>
VM7-M26D-03015-D2FN	380	30000	191	1500	2000	58	116	382kg·cm <sup>2</sup>
VM7-M26D-03715-D1FN	380	37000	236	1500	2000	72	144	445kg·cm <sup>2</sup>
VM7-M26D-03715-D2FN	380	37000	236	1500	2000	72	144	461kg·cm <sup>2</sup>
VM7-M26D-04515-D1FN	380	45000	286	1500	2000	87	174	529kg·cm <sup>2</sup>
VM7-M26D-04515-D2FN	380	45000	286	1500	2000	87	174	550kg·cm <sup>2</sup>
VM7-M26D-05515-D1FN	380	55000	350	1500	2000	106	212	639kg·cm <sup>2</sup>
VM7-M32D-05510-S1FN	380	55000	525	1000	1300	110	215	1370kg·cm <sup>2</sup>
VM7-M32D-07510-S1FN	380	75000	716	1000	1300	142	280	1830kg·cm <sup>2</sup>
VM7-H40D-07506-S1W	380	75000	1200	600	720	160	352	5294kg·cm <sup>2</sup>
VM7-M32D-09010-S1FN	380	90000	859	1000	1300	171	339	2290kg·cm <sup>2</sup>
VM7-M32D-10815-S1FN	380	108000	690	1500	2000	206	412	1830kg·cm <sup>2</sup>
VM7-M32D-11010-S1FN	380	110000	1050	1000	1300	199	385	2750kg·cm <sup>2</sup>

Servo motor installation dimension

40mm flange

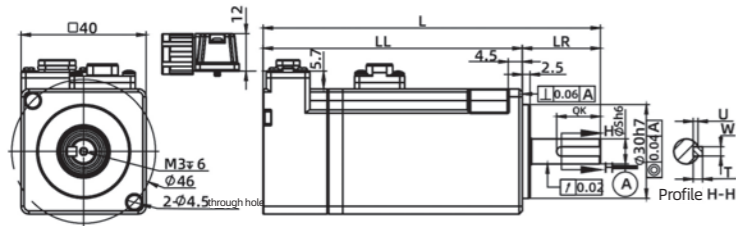

Unit: mm

Model	L	LL	LR	S	QK	U	W	T
V7E-L04A-R1030-□1	108	83	25	8	14	1.5	3	3
V7E-L04A-R1030-□2	134	109	25	8	14	1.5	3	3

60mm flange

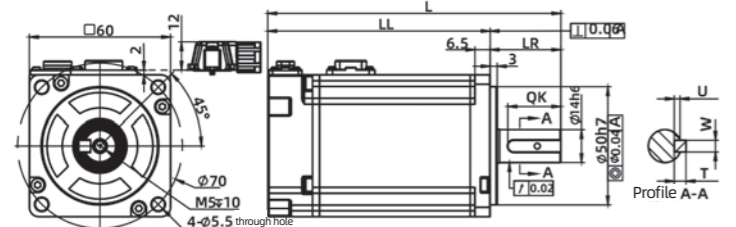

Unit: mm

Model	L	LL	LR	S	QK	U	W	T
V7E-L06A-R2030-□1	105.5	75.5	30	14	22.5	2.5	5	5
V7E-L06A-R2030-□2	136.5	106.5	30	14	22.5	2.5	5	5
V7E-L06A-R4030-□1	124.5	94.5	30	14	22.5	2.5	5	5
V7E-L06A-R4030-□2	155.5	125.5	30	14	22.5	2.5	5	5
V7E-M06A-R4030-□1	134.5	104.5	30	14	22.5	2.5	5	5
V7E-M06A-R4030-□2	165.5	135.5	30	14	22.5	2.5	5	5
V7E-L06A-R6030-□1	143.5	113.5	30	14	22.5	2.5	5	5
V7E-L06A-R6030-□2	174.5	144.5	30	14	22.5	2.5	5	5

80mm flange

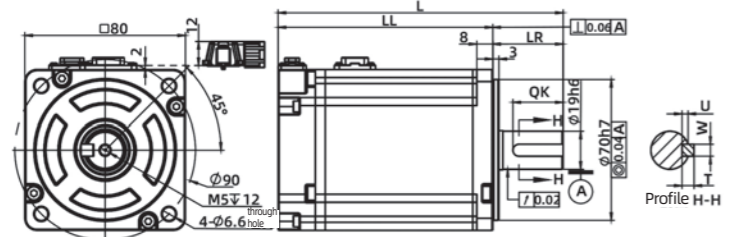

Unit: mm

Model	L	LL	LR	S	QK	U	W	T
V7E-L08A-R7520-□1L	156	121	35	19	25	3	6	6
V7E-L08A-R7520-□2L	188	153	35	19	25	3	6	6
V7E-L08A-R7530-□1L	142	107	35	19	25	3	6	6
V7E-L08A-R7530-□2L	174	139	35	19	25	3	6	6
V7E-M08A-R7530-□1L	152	117	35	19	25	3	6	6
V7E-M08A-R7530-□2L	184.5	149.5	35	19	25	3	6	6
V7E-L08A-R7530-□1	142	107	35	19	25	3	6	6
V7E-L08A-R7530-□2	174	139	35	19	25	3	6	6
V7E-M08A-R7530-□1	152	117	35	19	25	3	6	6
V7E-M08A-R7530-□2	184.5	149.5	35	19	25	3	6	6
V7E-L08A-1R030-□1	156	121	35	19	25	3	6	6
V7E-L08A-1R030-□2	188	153	35	19	25	3	6	6

110mm flange

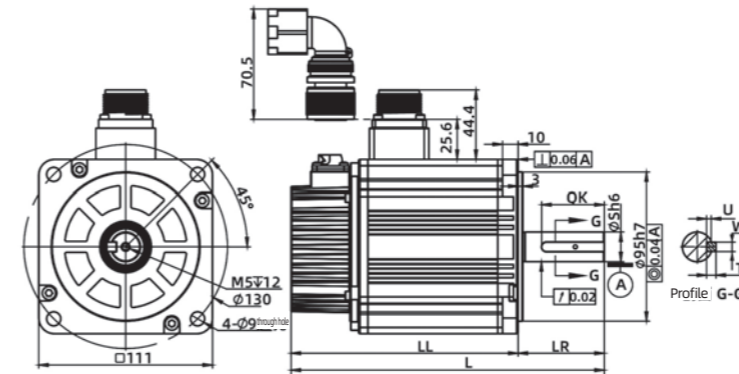

130mm flange

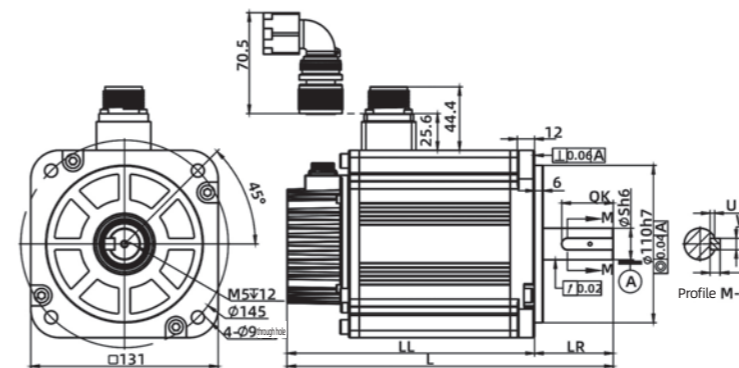

Unit: mm

Model	L	LL	LR	S	QK	U	W	T
V7E-M11A-1R230-□1	190	135	55	19	40	3	6	6
V7E-M11A-1R230-□2	221.2	166.2	55	19	40	3	6	6
V7E-M11A-1R530-□1	200	145	55	19	40	3	6	6
V7E-M11A-1R530-□2	231.2	176.2	55	19	40	3	6	6
V7E-M11A-1R830-□1	210	155	55	19	40	3	6	6
V7E-M11A-1R830-□2	241.2	186.2	55	19	40	3	6	6

Unit: mm

Model	L	LL	LR	S	QK	U	W	T
V7E-M13A-R8515-□1	193	138	55	22	36	3.2	8	7
V7E-M13A-R8515-□2	221.2	166.2	55	22	36	3.2	8	7
V7E-M13A-1R020-□1	193	138	55	22	36	3.2	8	7
V7E-M13A-1R020-□2	221.2	166.2	55	22	36	3.2	8	7
V7E-M13A-1R315-□1	208	153	55	22	36	3.2	8	7
V7E-M13A-1R315-□2	236.2	181.2	55	22	36	3.2	8	7
V7E-M13A-1R520-□1	208	153	55	22	36	3.2	8	7
V7E-M13A-1R520-□2	236.2	181.2	55	22	36	3.2	8	7
V7E-M13A-1R815-□1	228	173	55	22	36	3.2	8	7
V7E-M13A-1R815-□2	256.2	201.2	55	22	36	3.2	8	7
V7E-M13A-2R020-□1	228	173	55	22	36	3.2	8	7
V7E-M13A-2R020-□2	256.2	201.2	55	22	36	3.2	8	7
V7E-M13A-2R315-□1L	258	203	55	22	36	3.2	8	7
V7E-M13A-2R315-□2L	286.2	231.2	55	22	36	3.2	8	7
V7E-M13A-3R020-□1	258	203	55	22	36	3.2	8	7
V7E-M13A-3R020-□2	286.2	231.2	55	22	36	3.2	8	7
V7E-M13D-R8515-□1	193	138	55	22	36	3.2	8	7
V7E-M13D-R8515-□2	221.2	166.2	55	22	36	3.2	8	7
V7E-M13D-1R020-□1	193	138	55	22	36	3.2	8	7
V7E-M13D-1R020-□2	221.2	166.2	55	22	36	3.2	8	7
V7E-M13D-1R315-□1	208	153	55	22	36	3.2	8	7
V7E-M13D-1R315-□2	236.2	181.2	55	22	36	3.2	8	7
V7E-M13D-1R520-□1	208	153	55	22	36	3.2	8	7
V7E-M13D-1R520-□2	236.2	181.2	55	22	36	3.2	8	7
V7E-M13D-1R815-□1	228	173	55	22	36	3.2	8	7
V7E-M13D-1R815-□2	256.2	201.2	55	22	36	3.2	8	7
V7E-M13D-2R020-□1	228	173	55	22	36	3.2	8	7
V7E-M13D-2R020-□2	256.2	201.2	55	22	36	3.2	8	7
V7E-M13D-2R315-□1L	258	203	55	22	36	3.2	8	7
V7E-M13D-2R315-□2L	286.2	231.2	55	22	36	3.2	8	7
V7E-M13D-3R020-□1	258	203	55	22	36	3.2	8	7
V7E-M13D-3R020-□2	286.2	231.2	55	22	36	3.2	8	7
V7E-M13A-R8515-□1B	193	138	55	19	40	3.1	6	6
V7E-M13A-R8515-□2B	221.2	166.2	55	19	40	3.1	6	6
V7E-M13A-1R815-□1B	228	173	55	24	36	3.3	8	7
V7E-M13A-1R815-□2B	256.2	201.2	55	24	36	3.3	8	7
V7E-M13D-R8515-□1B	193	138	55	19	40	3.1	6	6
V7E-M13D-R8515-□2B	221.2	166.2	55	19	40	3.1	6	6
V7E-M13D-1R815-□1B	228	173	55	24	36	3.3	8	7
V7E-M13D-1R815-□2B	256.2	201.2	55	24	36	3.3	8	7



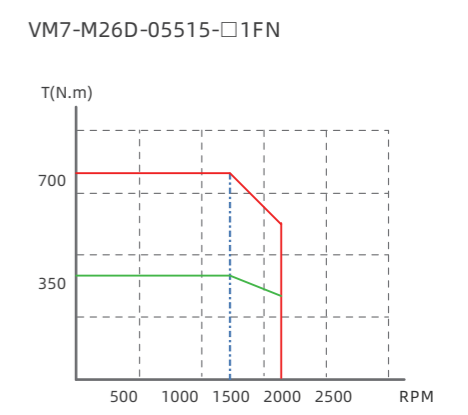
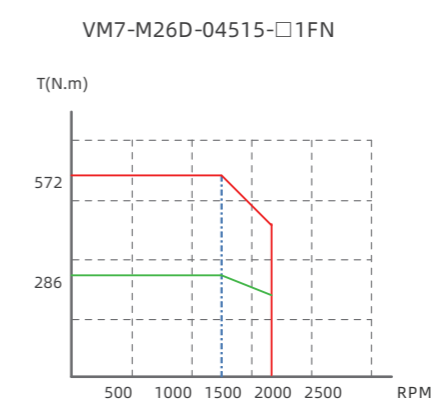
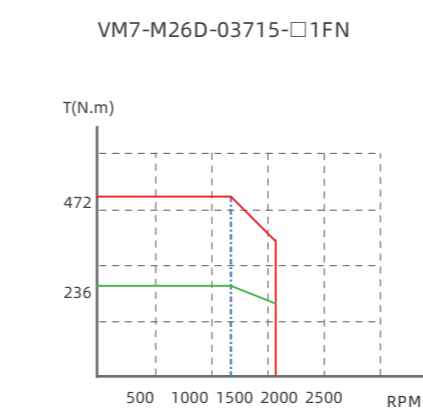
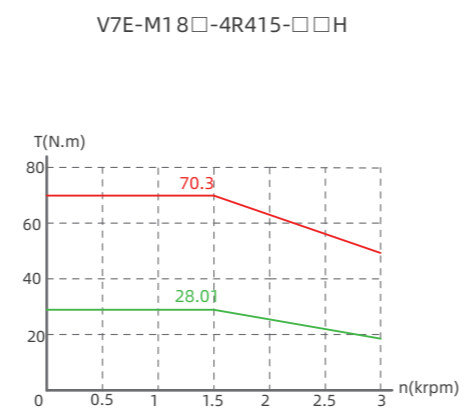
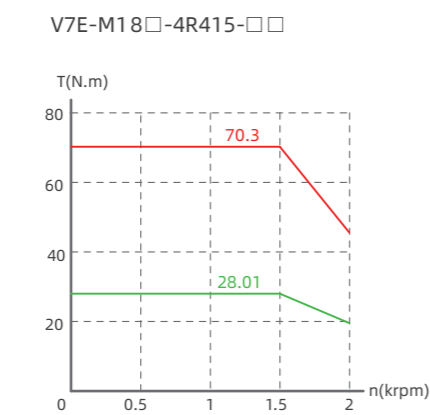
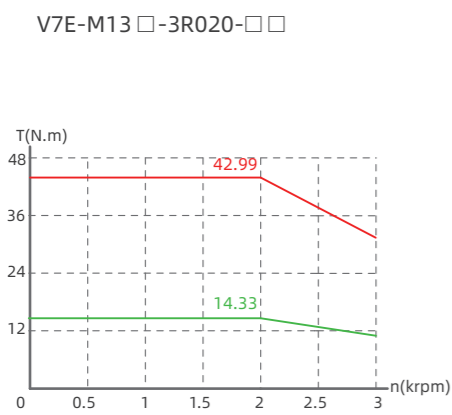
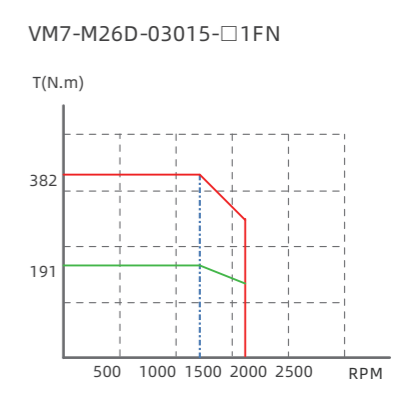
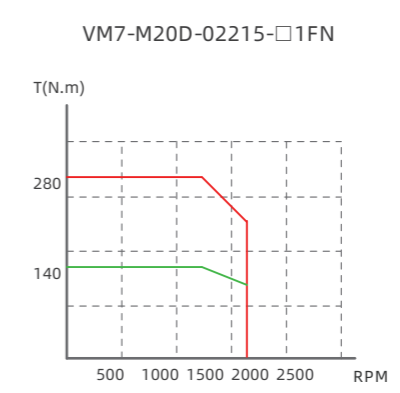
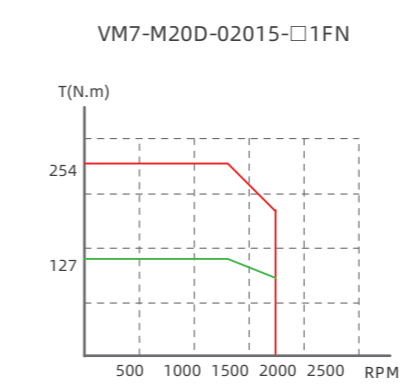
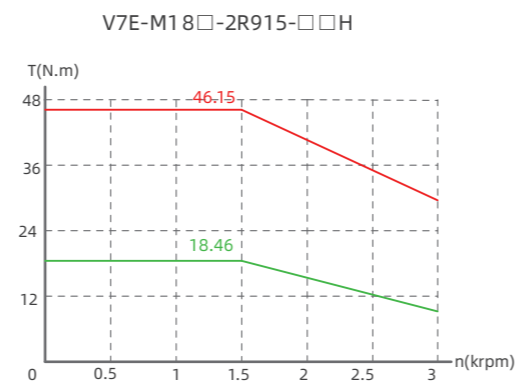
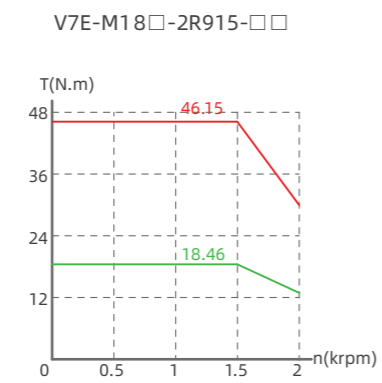
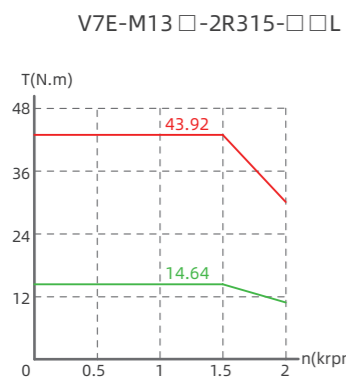
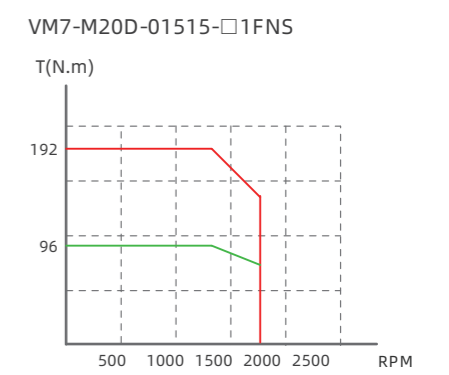
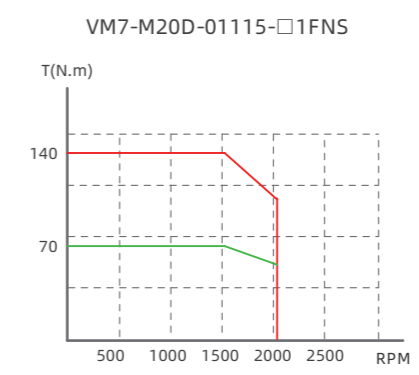
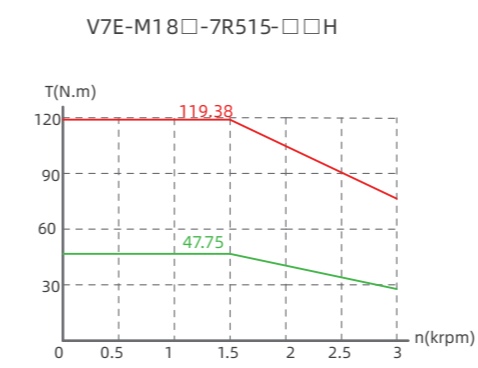
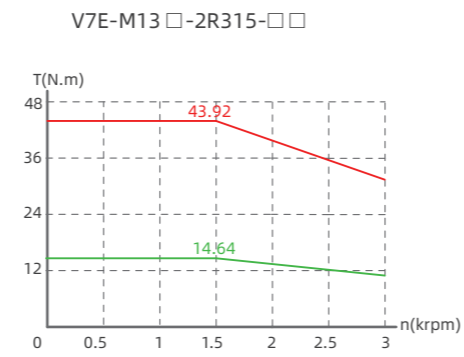
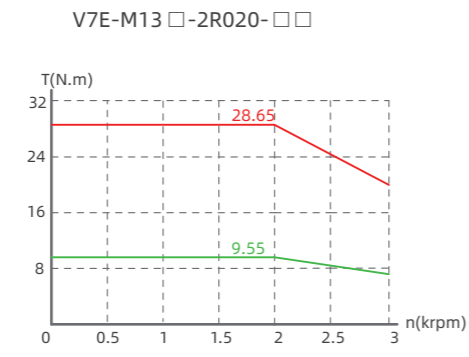
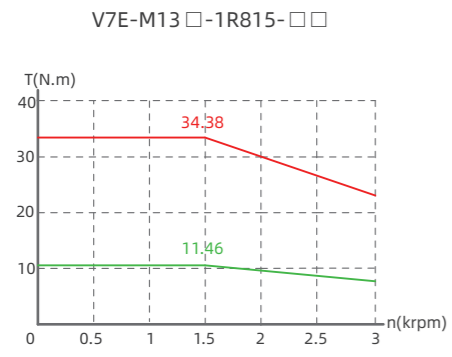
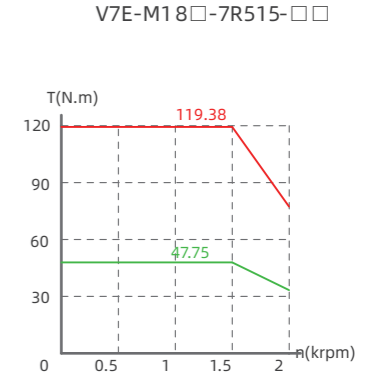
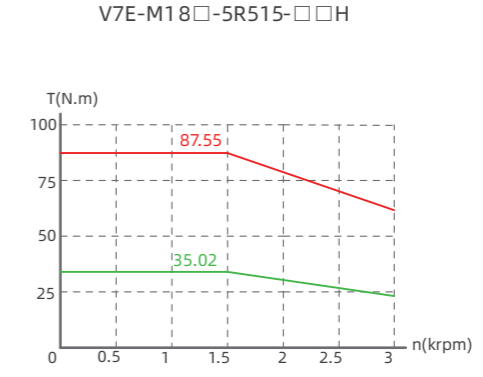
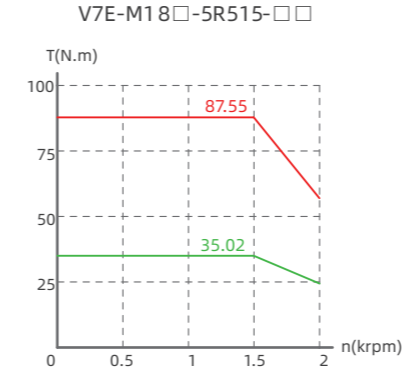
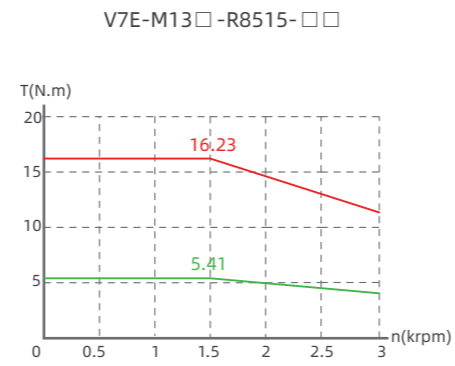
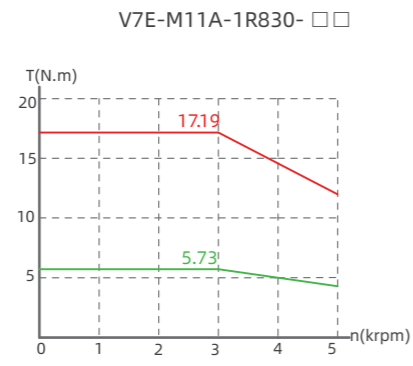
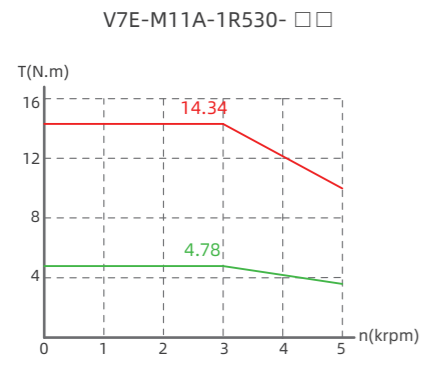

## Fan column

Fans are optional for 110 / 130 / 180 flange motors. For motors with fans, add "F" after the original model.

### Motor dimension with fans

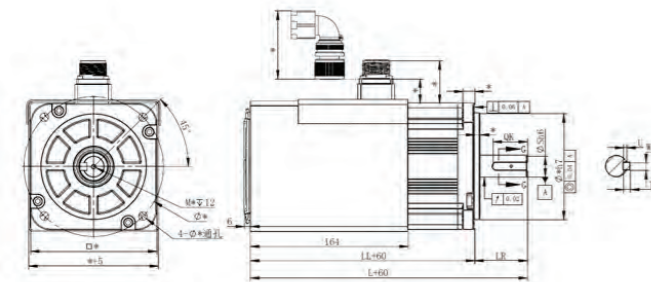

After the motor is equipped with fan, the machine length is increased by 60mm, and the other dimensions remain unchanged.

### Fan specification

	F12038N27A230
Voltage level / V	230±15AC
Rated current / A	0.135A
Rated air volume / CFM	89
Rated speed / rpm	2650

## Brake column

	Model	Static torque / N.m	Rated voltage/ V	Rated current / A
40	Z092-S040B(24V)0.38G8.5-001	0.38	24±10%	0.25
60	Z029-S060B(24V)1.5G12	1.5	24±10%	0.32
80	Z122-S080B(24V)3.8G16-002	3.8	24±10%	0.35
110	Z029-S110B(24V)10G21	10	24±10%	0.81
130	Z092-S130B(24V)16C25-002	16	24±10%	1
180	Z176-S180(24V)50C38	50	24±10%	2

## SD700 Servo drive cable introduction

### Power cable naming rules

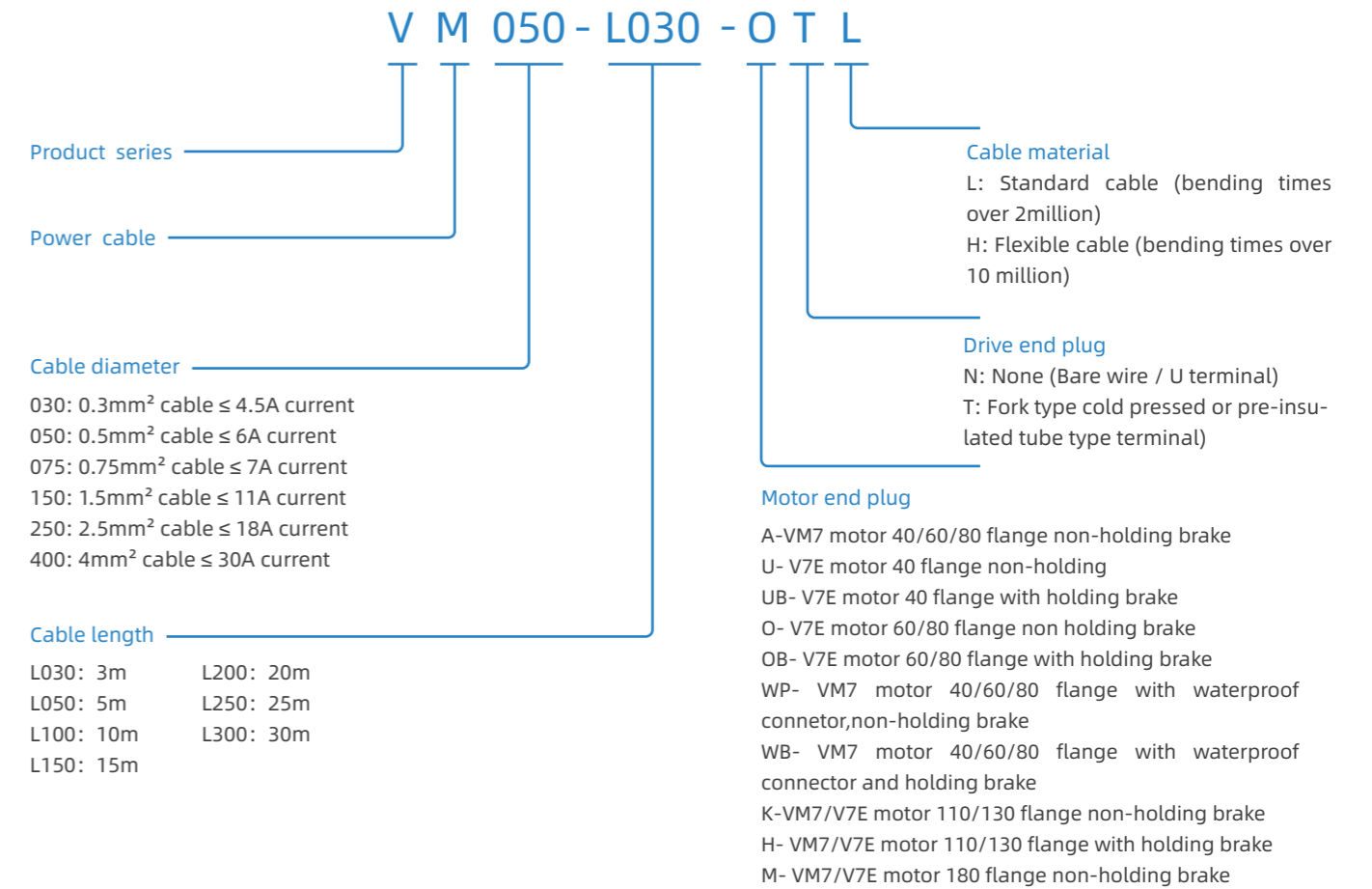

### Motor power cable

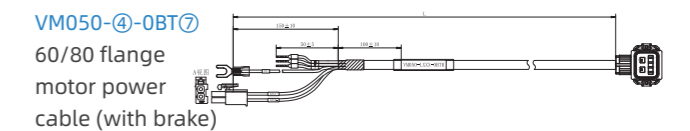
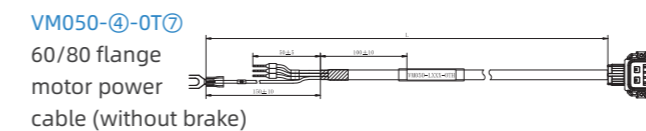
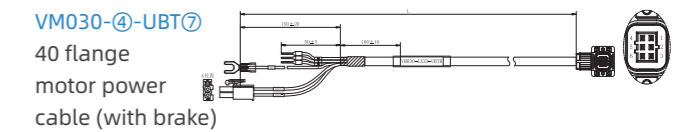
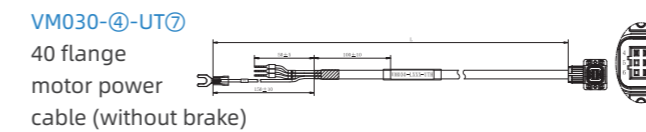

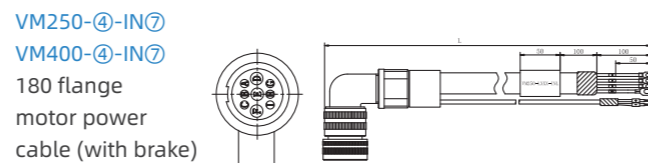
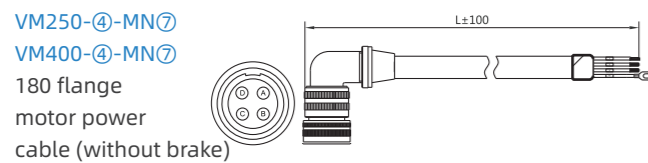
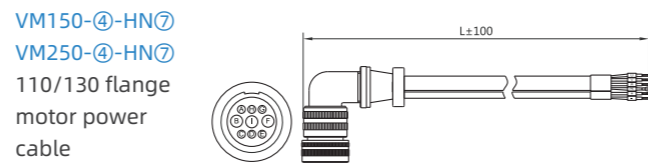
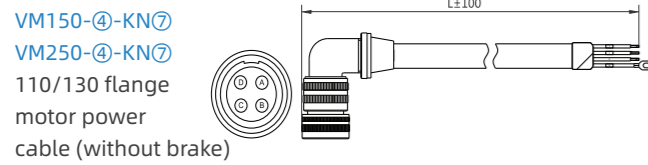

Encoder cable naming rules

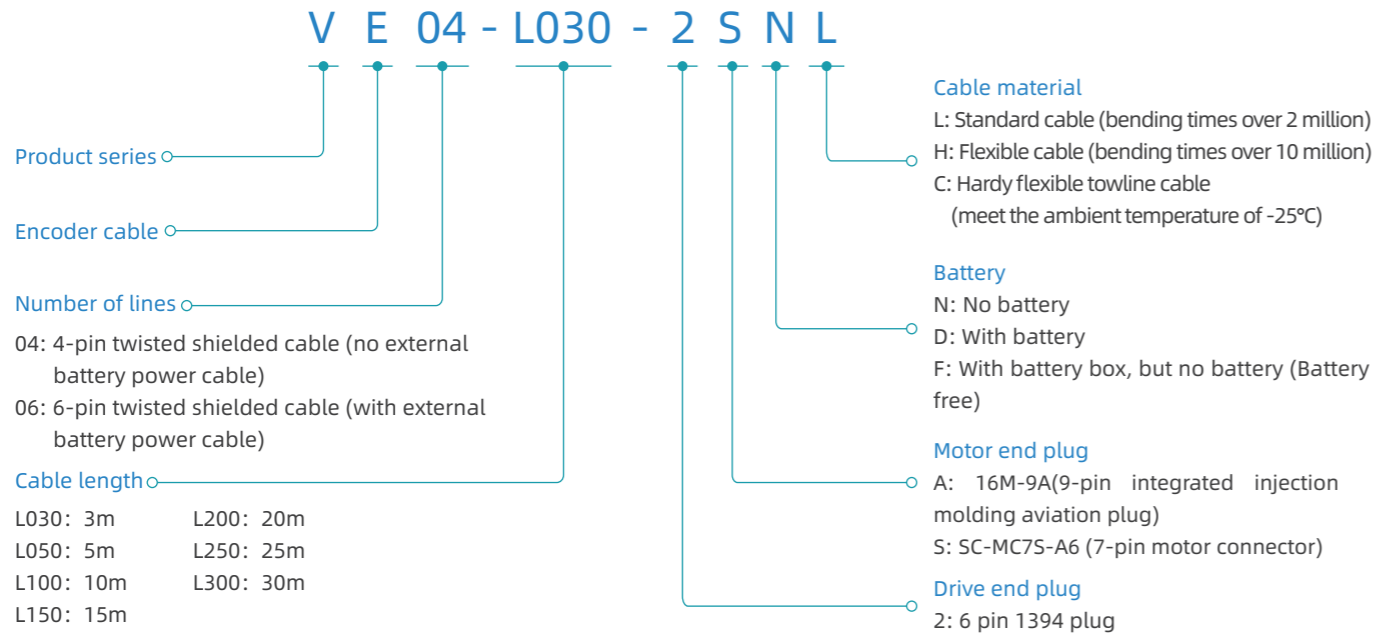

Note: The wire length of the encoder wire defined as " 2S" is more than 15 meters, you need to use the solution of the encoder wire defined as " 2A" plus the adapter wire.

Encoder cable

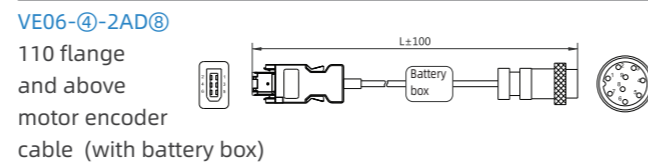
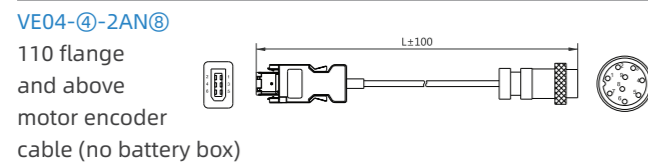
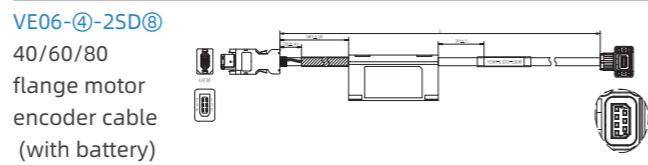
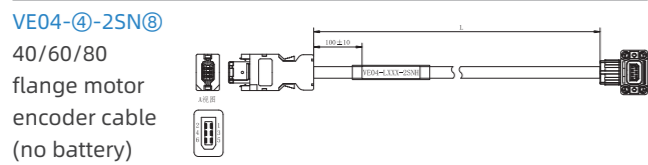

Transfer cable

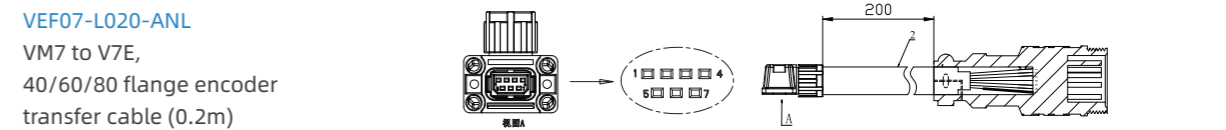
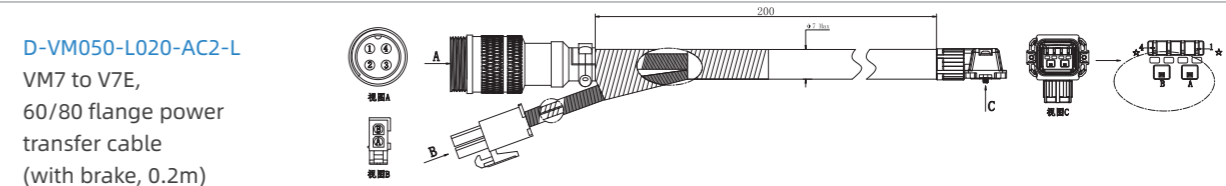
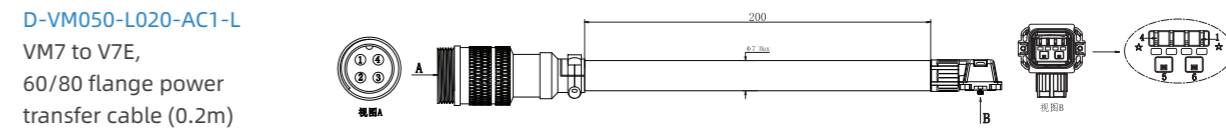
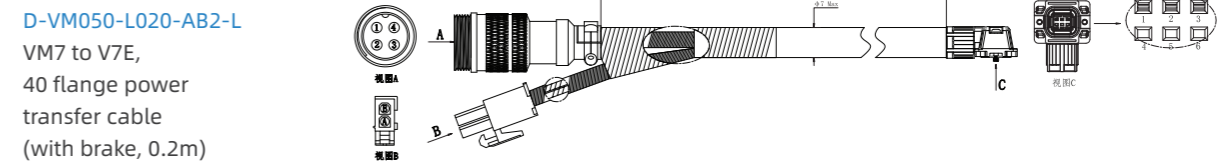
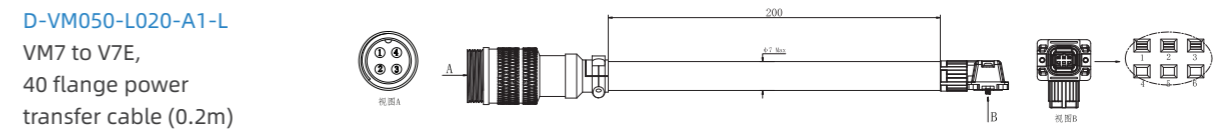

Braking resistor selection

Model	Braking voltage	Internal resistor	Min external resistance	Max external resistance
SD700-1R8A	380V	None	40Ω	200Ω
SD700-3R3A	380V	None	40Ω	100Ω
SD700-5R5A	380V	40Ω 6.0W	25Ω	70Ω
SD700-7R6A	380V	40Ω 6.0W	15Ω	50Ω
SD700-9R5A	380V	40Ω 6.0W	15Ω	40Ω
SD700-120A	380V	30Ω 2.00W	10Ω	30Ω
SD700-160A	380V	30Ω 2.00W	10Ω	30Ω
SD700-2R5D	700V	80Ω 6.0W	80Ω	220Ω
SD700-3R8D	700V	80Ω 6.0W	55Ω	180Ω
SD700-6R0D	700V	40Ω 6.0W	35Ω	110Ω
SD700-8R4D	700V	40Ω 6.0W	25Ω	85Ω
SD700-110D	700V	40Ω 6.0W	25Ω	70Ω
SD700-170D	700V	30Ω 2.00W	30Ω	50Ω
SD700-240D	700V	30Ω 2.00W	15Ω	40Ω
SD700-300D	700V	30Ω 2.00W	15Ω	30Ω
SD700-500D	700V	None	10Ω	20Ω
SD700-600D	700V	None	10Ω	20Ω
SD700-700D	700V	None	10Ω	15Ω
SD700-800D	700V	None	10Ω	15Ω
SD700-121D	700V	None	8Ω	10Ω
SD700-171D	700V	None	6Ω	8Ω