

Solution for Machine Tool Industry



VEICHI

Suzhou Veichi Electric Co., Ltd

No.1000 Songjia Road,Guoxiang street,Wuzhong Economic and Technological Development Zone,Suzhou

Tel: +86-512-6617 1988 Fax: +86-512-6617 3610

Facebook: <https://www.facebook.com/veichigroup>

WhatsApp: +86-138 2881 8903

<https://www.veichi.com/>



Official Website

Version: Y5/2-02

Any contents in this book are subject to change without notice. Veichi Electric Co., Ltd all rights reserved, reproduction in all its forms is strictly prohibited.

About us



Since its inception, VEICHI Electric (Stock Code: 688698) has been a pioneer in electrical transmission and industrial control, specializing in the research, development, production, and distribution of advanced industrial automation products. It serves a global clientele, delivering competitive, secure, and reliable solutions across multiple regions with R&D centers and production facilities in Suzhou, Shenzhen, and Xi'an, along with a wholly-owned subsidiary in India.

The comprehensive product portfolio, including AC drives, servo systems, and control systems, is widely applied in various industries, providing tailored solutions that drive the digital and intelligent transformation of modern manufacturing. Additionally, we are expanding into emerging fields such as robotics, new energy, and medical technologies, offering innovative products like coreless motors, frameless motors, photovoltaic storage inverters, and surgical power systems.

Along the way, VEICHI has developed a robust suite of proprietary technologies with relentless efforts on motors such as vector control, HF injection control, parameter

auto-tuning, motor protection, start-up fly track, high-speed weak magnet control, scalar V/F control, high-density water-cooled layout, and IGBT protections. As of September 30, 2024, we hold 222 authorized patents, including 54 invention patents.

And in consequence, it has reaped prestigious accolades, including the third batch of "Specialized, Elaborative, Characteristic, and Emerging 'Little Giant' Enterprise", "High-Tech Enterprise", "High and New Technology Enterprise", "Jiangsu Provincial Engineering Technology Research Center", "Jiangsu Provincial Enterprise Technology Center", and "Jiangsu Province Industrial Internet Development Demonstration".

Looking ahead, VEICHI remains unwavering in its commitment to a market-driven and cutting-edge technological innovation. By prioritizing breakthroughs in core technologies, it aims to expand into high-performance, high-quality, and high-reliability applications and drives transformative progress that shapes the future of the electrical transmission and industrial control.

2005

- Business started in Shenzhen
- First generation of drive on the market

2014

- Suzhou Veichi first-stage project put into construction

2019

- Veichi restructured to a company limited by shares
- Indian subsidiary established

2013

- Suzhou Veichi Electric Co., Ltd established
- First generation of servo system on the market

2016

- Suzhou Veichi first-stage project put into operation
- First generation of motion control system on the market

2020

- A-share science and technology innovation board landing successfully
- Veichi honored with Jiangsu Province Specialized and Sophisticated Enterprise That Produces New and Unique Products

2021

- Veichi subsidiary corporation established
- Veichi honored with national -level Specialized and Sophisticated Enterprise That Produces New and Unique Products

2022

- Xi'an R&D center established
- Veichi digital energy subsidiary corporation established

2023

- Suzhou Veichi second-stage project put into operation
- Suzhou Veichi third-stage project put into construction
- Veichi medical facility subsidiary established

2024

- Intelligent manufacturing factory and digital transformation project successfully closed down

Brief

With decades of expertise in machine tool industry solutions, VEICHI now boasts flagship products including V800 Series Controllers, SD860 Multi-Drive Servo Drives, SD700 High-Performance Servo Drives, SD500 Spindle Servo Drives, which are all aligned with "Made in China 2025" to full electro-control solutions.

Control Layer

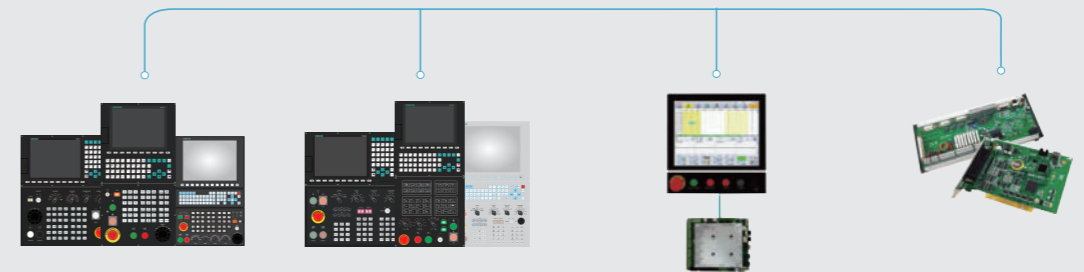

Lathe controller Milling machine controller All-Electric bending controller Laser cutting controller

Drive Layer



SD500 Spindle servo drive AC310-C Spindle AC drive SD860 Multi-drive servo system SD700 High-performance servo drive SD710 Economic servo drive

Execution Layer



Spindle motor Electric spindle V7E motor High-speed liquid-cooled motor Direct drive motor

01 CNC Lathe Solutions

Advantages:

1. Multi-protocol drive communication and a wide range of intelligent sensor modules
2. Bus-based I/O system and 6-path & 32-axis control for advanced motion coordination
3. Sub-nanometer precision and high-speed, high-accuracy interpolation for advanced turning and milling applications
4. Smart functionality suite and dual-system dedicated features for enhanced performance
5. User-friendly open HMI for seamless operation

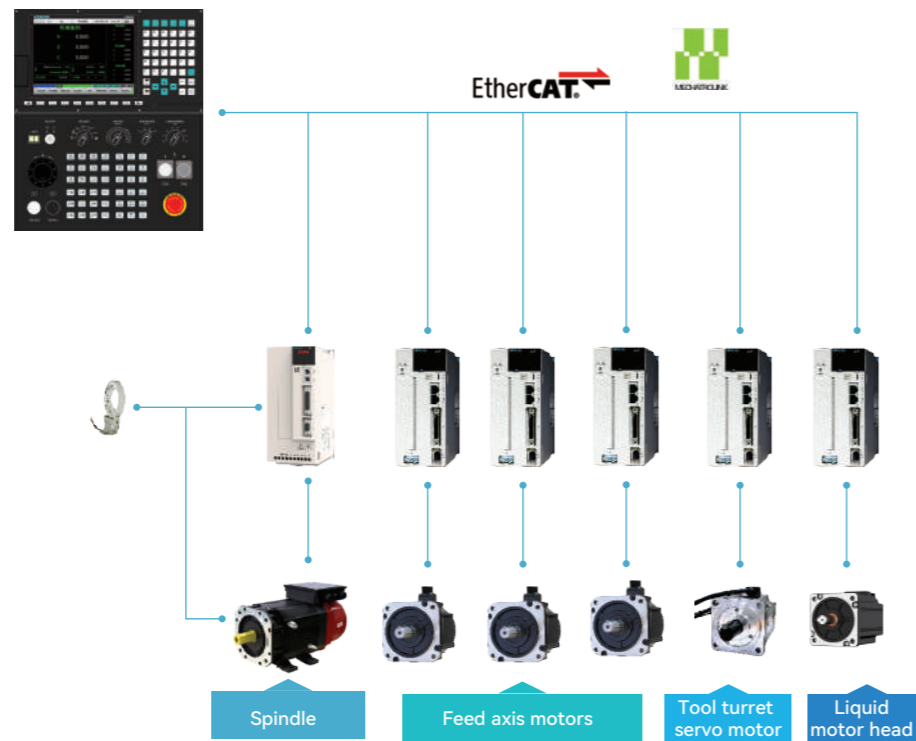

03 Laser Surface Cutting Solutions

Advantages:

1. Tamagawa 23-bit encoders ensure superior accuracy for sharp, smooth contours
2. Machine-tool grade servo motors minimize axial/radial runout with high resistance to load and exceptional stability
3. Multi-protocol fieldbus support (EtherCAT and MECHATROLINK-II/III) for flexible and simplified wiring

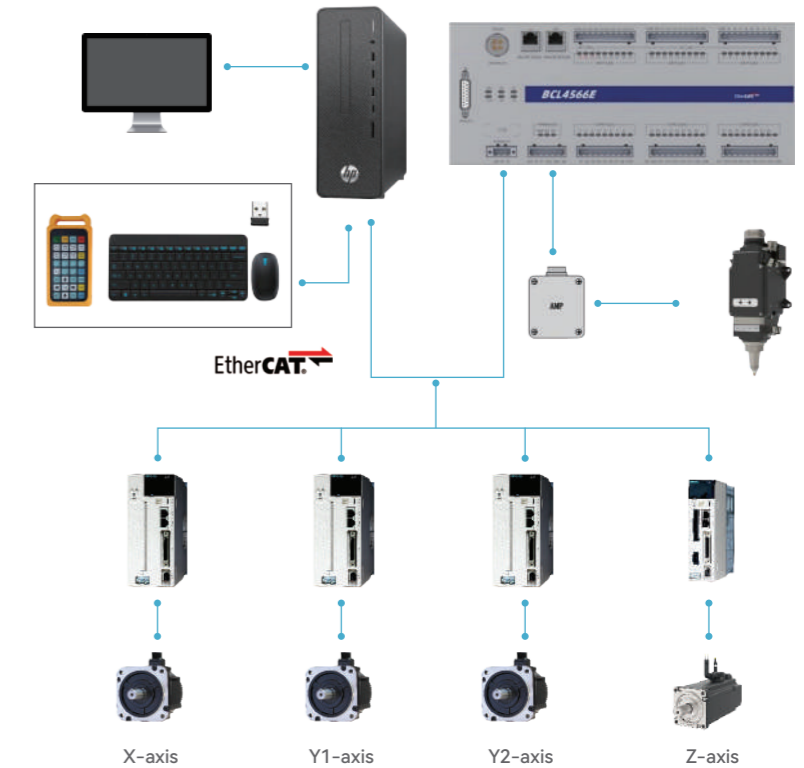

02 CNC Milling Machine Solutions

Advantages:

1. High-speed & high-precision cutting for flawless execution of machining programs
2. Real-time PLC for enhanced control on peripheral devices
3. Open architecture with PLC, Macro programming and QUI-Designer
4. File protection function for critical data and program integrity
5. Instant support from Online Help function
6. Quick reference by the G/M code



04 All-electric Bending Center Solutions

Advantages:

1. Bending-specific advanced algorithm for superior servo motor overload & stall resistance and torque arrival detection with real-time load monitoring and system feedback
2. World-class current loop algorithm + proprietary model-following technology for faster response and higher precision
3. Multi-protocol fieldbus support (EtherCAT and MECHATROLINK-II/III) for flexible and simplified wiring
4. Machine-tool grade servo motors with minimized axial runout, higher resistance to load and exceptional stability
5. Tamagawa 23-bit high-resolution encoder applicable for high accuracy, rapid response, and optimized efficiency

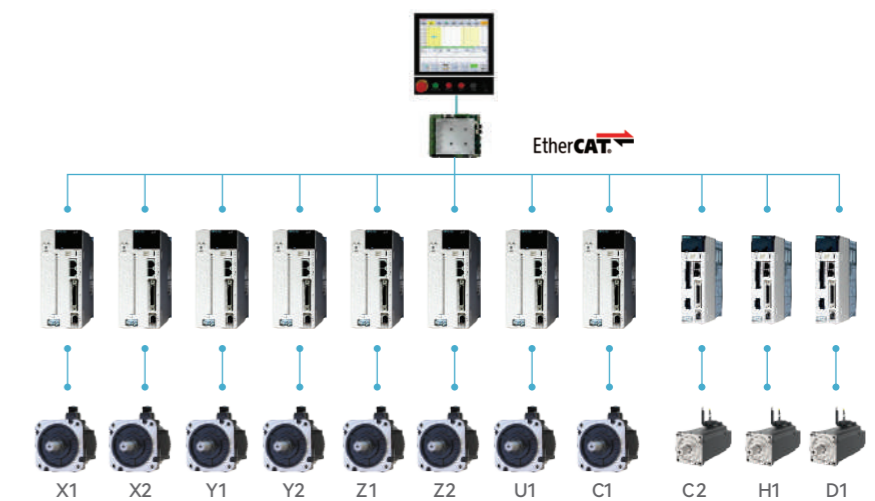

Intelligent Full Automation:

Precision Bending, Limitless Configurations



05 Laser Tube Cutting Solutions

Advantages:

1. Tamagawa 23-bit encoders ensure superior accuracy for sharp, smooth contours
2. Machine-tool grade servo motors minimize axial/radial runout with high resistance to load and exceptional stability
3. Multi-protocol fieldbus support (EtherCAT and MECHATROLINK-II/III) for flexible and simplified wiring

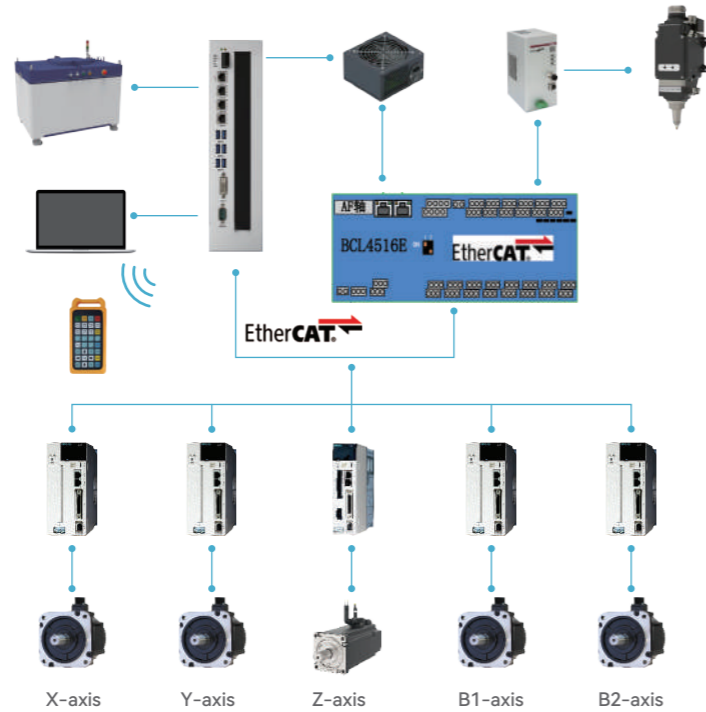

Lathe Controller

- Robust secondary development support with multi-protocol compatibility including EtherCAT and MECHATROLINK-III
- Enhanced computing core and dual-channel support for demanding machining operations
- Sophisticated applications like turn-mill complexes and lathe-robot combined systems
- Fanless design with superior oil and dust resistance for harsh environments
- User-friendly interface with complete functionality and reliable performance
- Smart sensors and cloud platforms for Industry 4.0 intelligent manufacturing solutions



Multi-protocol drive communication
EtherCAT Fieldbus with smart sensor
High-speed bus I/O system



6-path & 32-axis for complex production
Sub-nanometer grade core accuracy
Advanced turning-milling demand compatibility



Smart functionality suite and dual-system dedicated features
User-friendly open HMI

06 Spring Machine Bus Solutions

Advantages:

1. EtherCAT-based solution delivers cycle-synchronous motion control, minimizing servo position deviation and reducing settling time for optimal accuracy
2. EtherCAT bus communication eliminates complex wiring for easier expansion and lower reduces error potential
3. Powerful host software simplifies debugging for superior processing results
4. Advanced servo compensation algorithms significantly improve resistance to external load variations
5. Proprietary model-tracking and speed feed-forward technologies maximize servo responsiveness for ultra-precise motion control
6. Custom-configured servo motors based on specific process and load requirements deliver exceptional running stability and positioning accuracy

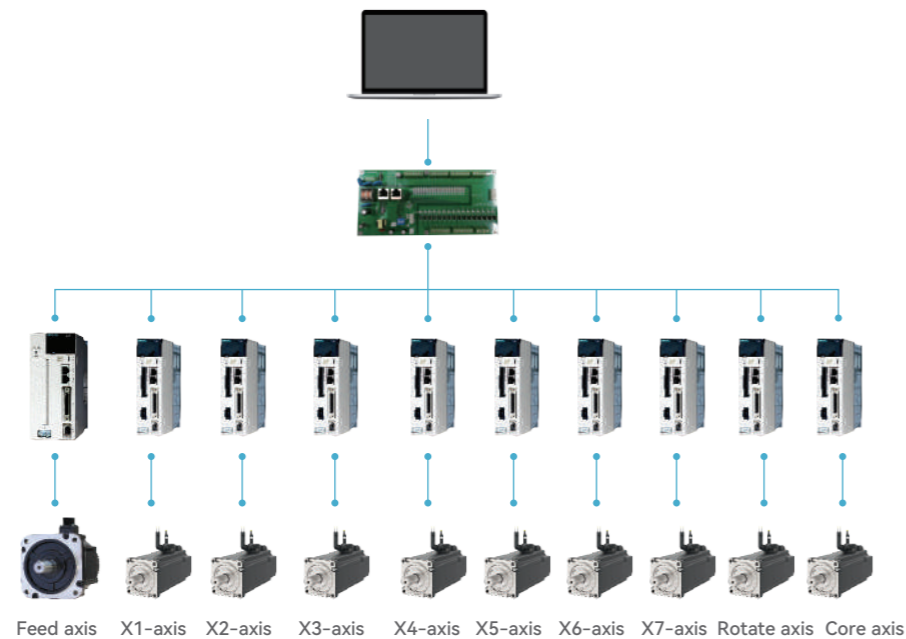

Lathe Controller Products



V800TA



V800TB



V800TP

Applications



Swiss-type Turning



Twin Tool Turret



Turning-milling Machine



Horizontal Lathe



Vertical Lathe

Software Functions

New Coordinates and Load Monitor Interface

Coordinates, programs, and graphs viewed simultaneously to minimize page changes and real-time monitoring of load conditions through bus communication.



Command Highlights & Instant Search

Processing program commands highlighted for easier viewing and instant auxiliary instructions to facilitate terminal programming.

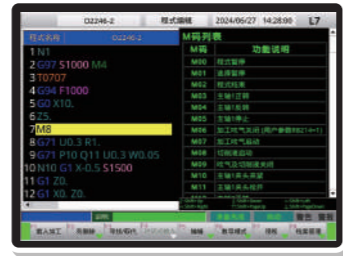

Elliptical Machining

X-axis and spindle coordinated for machine elliptical and cam profiles.



Intelligent Servo Tailstock

Real-time torque adjustment (no auxiliary springs required). Absolute servo system without homing blocks.



Threading Diagnostics

System calculation of commanded threading angles. Stable threading ensured when actual angles match commands.



Arc Threading

Arc threading available for specialized processes.

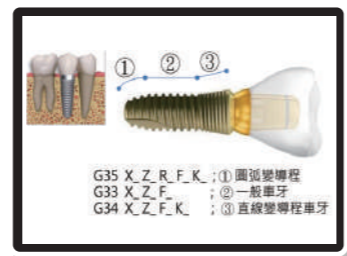

Online Oscilloscope

Built-in diagnostics for I/O status and PLC logic and timing issues.

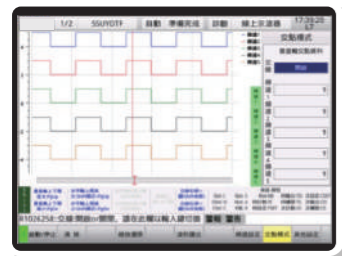

Circularity Verification

Guaranteed workpiece accuracy during initial machining. Reduced downtime, scrap rates, and inspection costs.

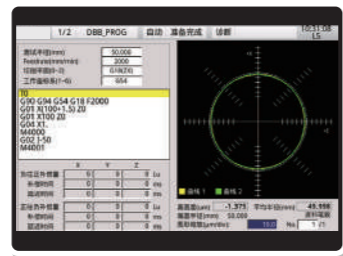

Chip Breaking

High-frequency reciprocating motion of the feed axes to achieve recutting, recommended for roughing, but can also be used for finishing.

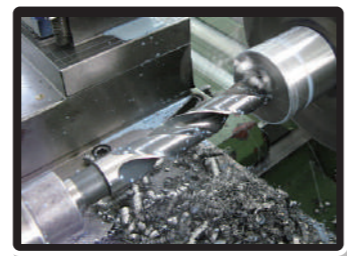

Smart Tool Load Monitoring

Auto-tuning of cutting loads for predictive tool life and load-based smart tool life management.



Lathe Graphic Interface

Mechanical position graphics available for system commands and actual motor feedback.

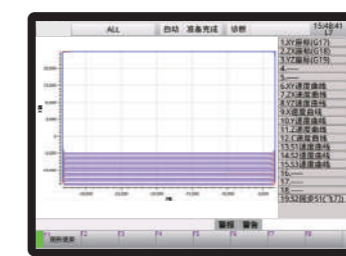

Finish Turning Allowance

Automatic adjustment of allowance direction along contours.

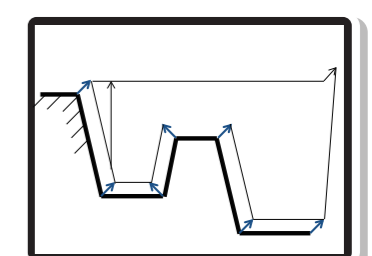

Dual-system Dedicated Functions

Synchronous/Phase-Matched Spindles

Main and sub-spindles synchronize for seamless transfer of round/polygonal workpieces.

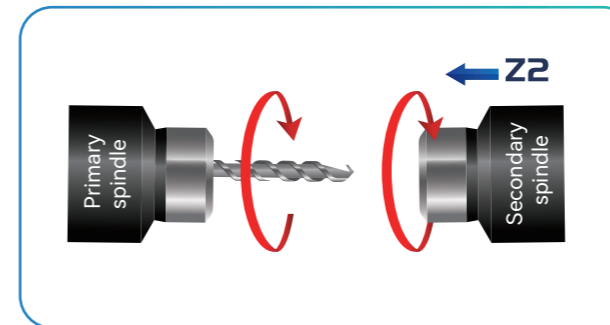

Servo Axis Sync Control

Ideal for long workpiece machining (e.g., threading, tapping, knurling).

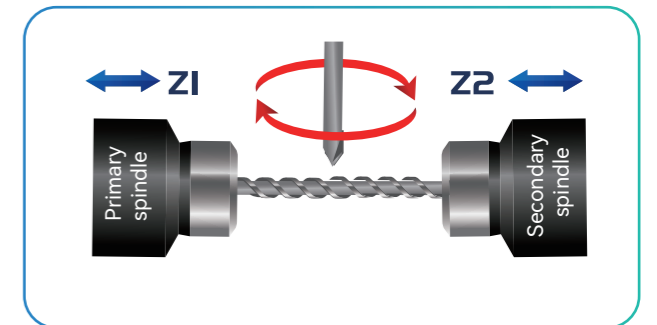

Servo Axis Overlap

Side milling or tapping on the sub-spindle while the main spindle runs continuously, minimizing idle time.

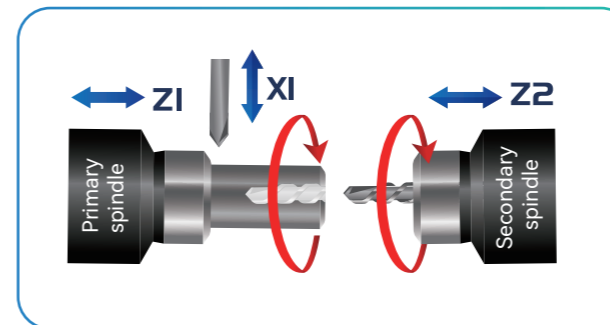

Hybrid Control

Programmable command-swapping for cross-path servo axis control.

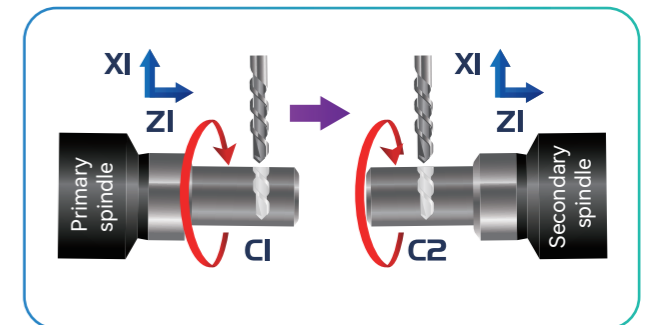

2-in-1 Control of Lathe & Robot

Random Position Setting



Tray Stacking Setting

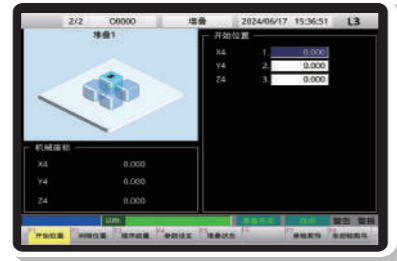

G-code Programming for Lathe Robot



Text-based Instruction



Protected Zone Setting

Prohibited areas easily set by teaching

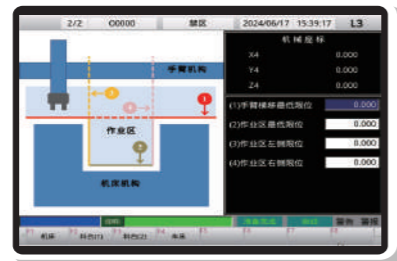

Diagnosis & Monitoring

Dynamic display of current robot movements



M-code Configuration

M-code available if needed



Full Tool Stacking

Fast machine processing management



Point Coordinates Designation

Preset function point position for teaching



Fast Import to Cloud

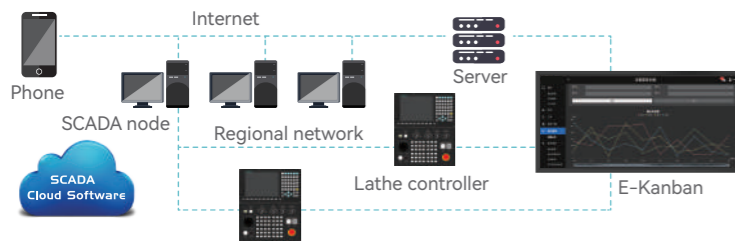

Cloud-based monitoring software enables real-time tracking of product quality and production efficiency. When defects occur, the system retrieves historical quality data for root-cause analysis, helping optimize production decisions and prevent recurrence. This smart manufacturing approach is ideal for high-precision mass production, which fulfills the needs of intelligent production line management and transparent production data visibility.

Function features

- Monitor production quality and consolidate statistical analysis data on the server.
- Access real-time work order status, machine conditions, and other production information anytime via the network.
- Customizable user permissions ensure secure data access and operations based on authorization levels.
- Upload/download and instantly review current machining programs online.
- Schedule machine maintenance with advance reminders; alerts are triggered for overdue tasks.
- Send instant anomaly alerts via Email/Line/WeChat/SMS to designated personnel when equipment issues occur.

Product Specification

Specification	V800TA	V800TB	V800TP
Screen size		10.4"	15"
Axial port		2	2
Communication		M III/EtherCAT	M III/EtherCAT
D/A output		2	2
MPG port		1	1
Input channel		128	128
Output channel		128	128
Front USB port		○	○
Front network port		--	--
Built-in handwheel		○	○
LED tool No. display		○	○
Controlled path No.		2	2
Controlled axis No.		9	9
Spindle No.		6	6

Note: ○ means: yes, -- means: no.

Accessory Specification

Specification	SIOA1700	SIOA1760R
Input voltage	DC24.0±10%	DC24.0±10%
Input current	1.5A	--
Input channel	22	16
Output channel	16	16
Input power	DC24V	DC24V
Optocoupler input	PNP/NPN switchable	PNP/NPN switchable
Output	Transistor low-level output contact, max: 200mA	Contact rating: AC250V 2A/DC30V 2A

Note: ○ means: yes, -- means: no.

Milling Machine Controller

- Robust secondary development support with multi-protocol compatibility including EtherCAT and MECHATROLINK-III.
- Enhanced computing core and dual-channel support for demanding machining operations.
- Fanless design with superior oil and dust resistance for harsh environments.



High-performance motion control technology
High-speed & high-precision cutting for flawless execution of machining programs
Real-time PLC for enhanced control on peripheral devices

Secondary development toolkit and architecture
PLC
Motion Macro language
Open architecture HMI (QUI-Designer)

Auxiliary functions
File protection
Online help
G/M code search

Milling Machine Controller

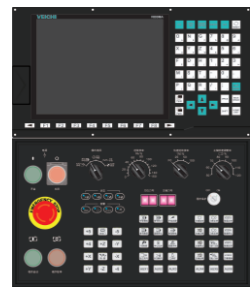

V800MA

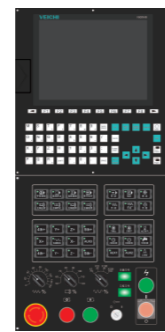

V800MB



V800MF

Applications



Machining Centers

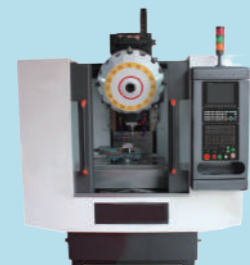

Drilling and Tapping Machines

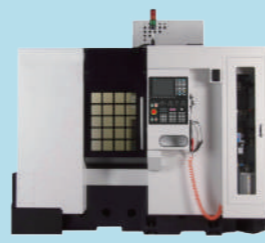

Milling Machines

Software Functions

Toolpath Preview

Pre-machining visualization to prevent operational errors

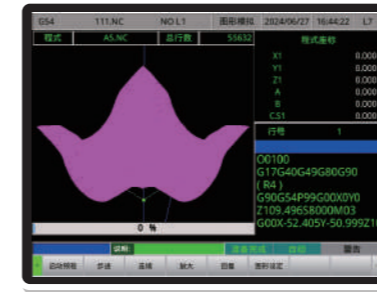

Automatic Tool Length Measurement

Intuitive HMI interface for simplified tool length input and operation



Macro Program Encryption

Non-decryptable protection on the encrypted macros



Structured Parameter Display

Grouped listing format with detailed descriptions
Isolated bit-type parameters for simplified setup (no manual calculations)



User-Friendly Tool Turret Debugging Interface

Pre-configured PLC functions and dedicated configuration pages for common tool libraries

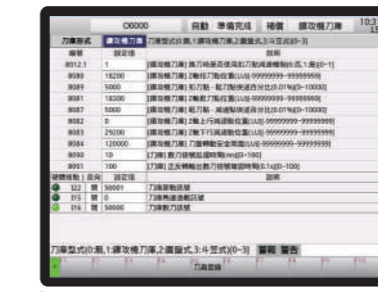

Intelligent Machining

Multi-level high-speed/high-precision options (including servo parameters) for manual or automated selection



CAD/CAM Program Smoothing

- Pre-smoothing of paths
- Reduced CAD/CAM transfer errors
- Enhanced machining speed and surface accuracy

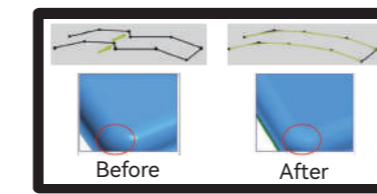

High-Speed & High-Precision Cutting

- Complete program detail rendering
- Ideal for precision engraving
- Pre-acceleration/deceleration
- Block look-ahead function
- Multi-block fitting technology

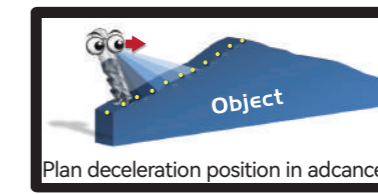

- Curve speed clamping
- Axis speed differential optimization
- Jerk control

Artificial Intelligence Control

Steel Die G05P4
Brass G05P3
Mg-Al Alloy G05P2

Three Major Development Tools

Macro Programming – High-Level Language Syntax

- ◎ VB-like syntax support
- ◎ Diverse built-in functions
- ◎ Specialized machining path generation (e.g., gears or tool processing) through mathematical operations
- ◎ Interface language for external communication, such as CCD

PLC Editor / Simulator / Waveform Debugging

- ◎ PLC Ladder Logic support
- ◎ Real-time PLC for more precise and stable peripheral control

HMI Development Tool – QUI Designer

- ◎ Drag-and-drop design interface with WYSIWYG
- ◎ Extended communication with motion programs via QUI-Macro, in addition to standard methods



Accessory Specification

Specification	SIOA1700	SIOA1760R
Input voltage	DC24.0±10%	DC24.0±10%
Input current	1.5A	--
Input channel	22	16
Output channel	16	16
Input power	DC24V	DC24V
Optocoupler input	PNP/NPN switchable	PNP/NPN switchable
Output	Transistor low-level output contact, max: 200mA	Contact rating: AC250V 2A/DC30V 2A

Note: ○ means: yes, -- means: no.

Product Specification

Specification	V800MA	V800MA	V800MF
Hardware	Screen size	10.4"	15"
	Axial port	2	2
	Communication	M III/EtherCAT	M III/EtherCAT
	D/A output	2	2
	MPG port	1	1
	Input channel	128	128
	Output channel	128	128
	Front USB port	○	○
	Front network port	--	--
	Built-in handwheel	○	○
	LED tool No. display	○	○
	Control	Controlled path No.	6
Controlled axis No.		32	32
Spindle No.		6	6

Note: ○ means: yes, -- means: no.

Naming Rules

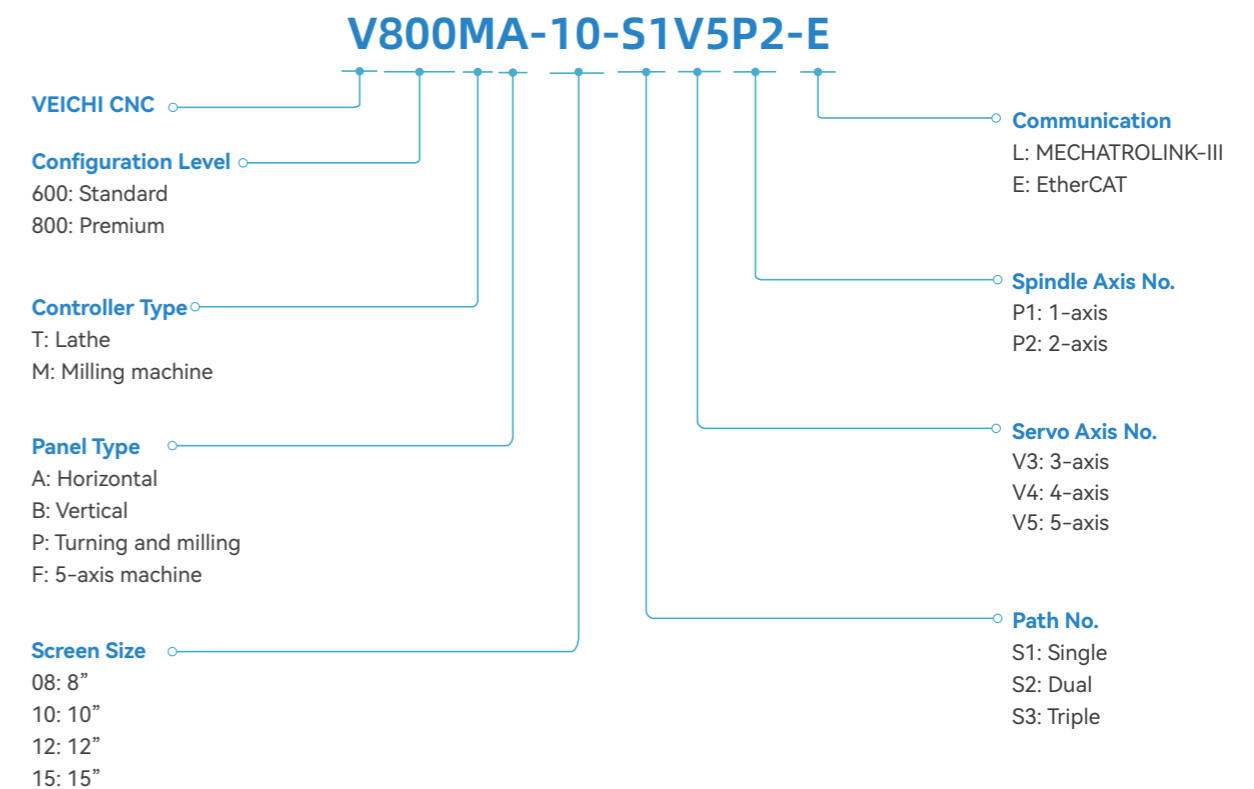

LS1 High-speed Liquid-cooled Motor

Powerheads for Mill-turn Machines

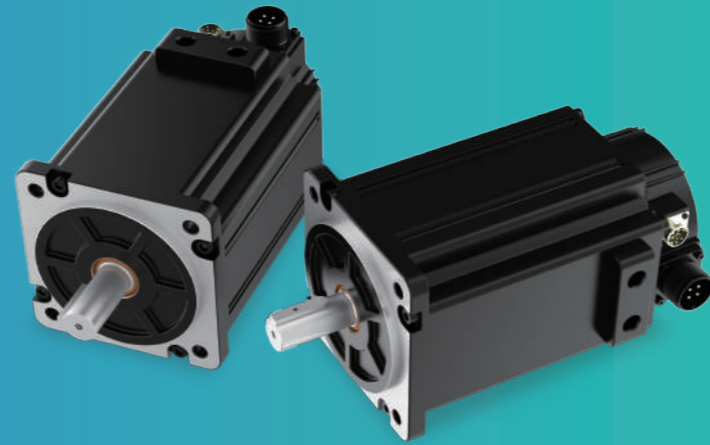

General Installation **Free Switching**

Compatible Design **Multiple Spigot Replacements**

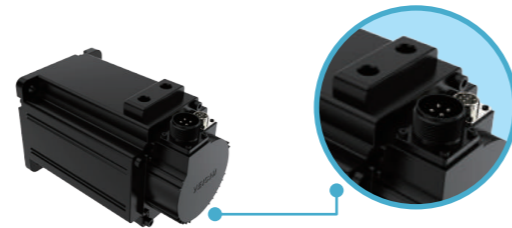

Low Temperature Rise
Liquid-cooled heat dissipation structure, suitable for high temperature environments with strong oil, dust or other pollution

Original temperature rise
60~75K
Current temperature rise
8~22K



Motor Head
Power heads for mill-turn machines



Usage

Liquid:

No. 5/10 spindle cooler oil, liquid-cooled purified water.

High RPM range:

Speed range 3000~8000(rpm), torque range 18~47.7(N·m)

Inlet/Outlet:

One-piece molded inlet and outlet to avoid the risk of welding leakage and liquid leakage.

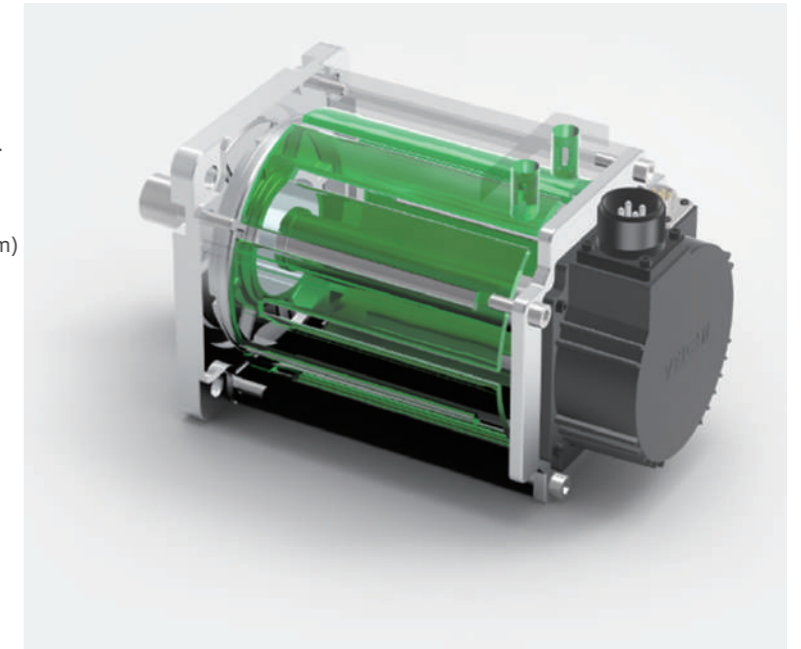

Naming Rules

LS1 - L 13 D - 5R5 30 - Q 1

Product Series
LS1 series

Inertia Level
L: Low

Flange
13: 130mm flange

Rated Voltage
D: 380V

Axis Extension
Keyed, without brake unit

Encoder Type
Q: 17-bit single-turn absolute encoder

Rated Speed
30: 3000rpm

Rated Power
5R5: 5.5kW

Technical Specification

Item	LS1-13D-5R530-□□
Voltage (V)	380
Power(kW)	5.5
Rated current (A)	18.2
Locked-rotor current (A)	21.8
Max. current(A)	48.6
Rated torque(N·m)	18
Locked-rotor torque(N·m)	21
Max. torque (N.m)	47.7
Rated speed (rpm)	3000
Max. speed (rpm)	8000
Straight-axis inductance Ld	1.66
Cross-axis inductance Lq	1.66
Rotor moment of inertia kg*cm ²	14.56
Work mode	S1 continuous operation
Pole number	10
Cooling method	IC87W
Ambient temperature	-20~40°C(non-condensation)
Ambient humidity	20%~90%RH(non-condensation)
Installation method	IM B3
Insulation class	Class F
Insulation voltage	AC1800V(1 min)
Housing IP	IP 67
Excitation mode	Permanent magnet
Excitation direction	Counterclockwise (CCW) rotation when viewed from the load side under a positive reference

Motor Sizes

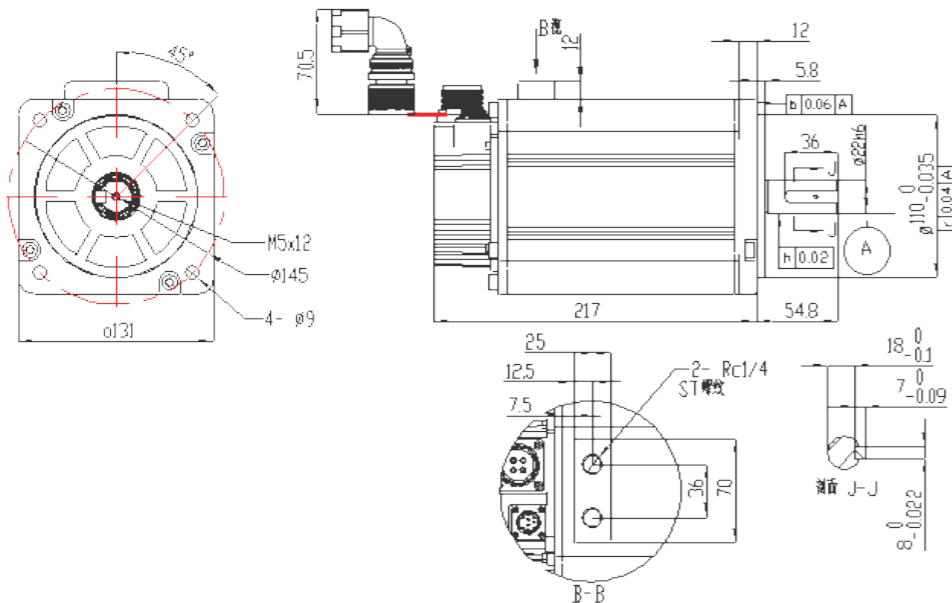

SD700 Series High-Performance Servo Drives



Speed loop response bandwidth up to 3kHz



Smart parameter configuration of inertia identification, loop gain and friction compensation



23-bit absolute encoder with 4Mpps high-speed communication



Multi-stage vibration suppression



Automatic bandwidth configuration and PID loop gain calculation



Robust control for stable operation with load inertia up to 30 times nominal



Comprehensive PC software, multi-channel monitoring, and user-friendly interface



New space-saving and streamlined structure

Servo Drive Naming Rules

SD 700 - 3R3 A - P A □

SD:
Servo drive

700:
High-performance servo drive

Rated Current:

(A) 220VAC				(D) 400VAC			
100	10A	7R6	7.6A	2R5	2.5A	110	11A
1R8	1.8A	9R5	9.5A	3R8	3.8A	170	17A
3R3	3.3A	120	12A	6R0	6.0A	240	24A
5R5	5.5A	160	16A	8R4	8.4A	300	30A

Product Management Code
Default for standard products

Encoder Type
A: Absolute

Drive Type
P: Pulse type
S: Standard
C: CANopen bus
E: EtherCAT
M: MECHATROLINK-II
L: MECHATROLINK-III
N: PROFINET bus

Rated Voltage
A: 220V AC
D: 400V AC

Appearance and Installation Dimensions

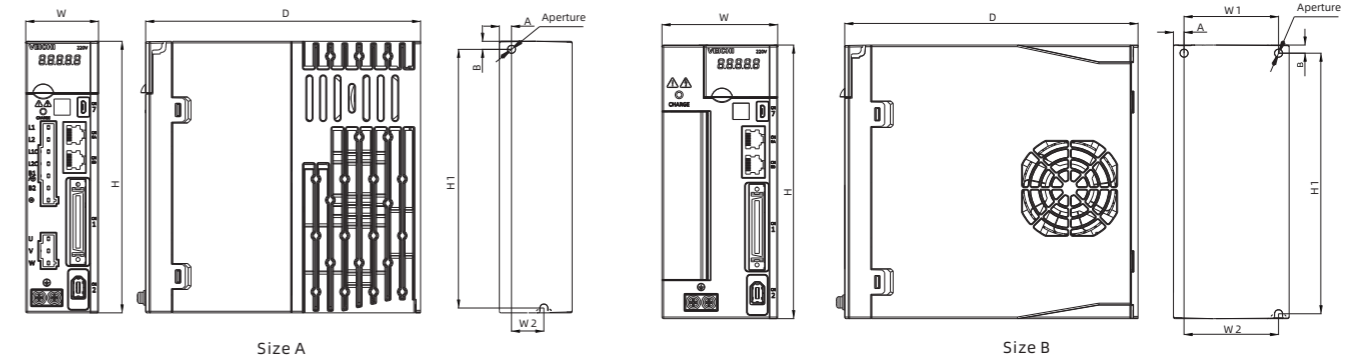

Case Type	Model	Overall Dimension(mm)			Installation Dimension(mm)						Aperture
		W	H	D	W1	W2	H1	H2	A	B	
A	SD700-1R1A-**-	45	168	170	\	20	160	\	7.5	5	2-M4
	SD700-1R8A-**-										
	SD700-3R3A-**-										
B	SD700-5R5A-**-	71	168	180	58	58	160	\	6.5	5	3-M4
	SD700-7R6A-**-										
	SD700-9R5A-**-										
	SD700-100A-**-										
	SD700-3R8D-**-										

Drive Power and Case Type

Model	Input	Output		Case Type
	Rated Voltage (V)	Rated Current (A)	Instantaneous Current (A)	
SD700-1R1A	Single-phase 220	1.1	3.9	A
SD700-1R8A	Single-phase 220	1.8	6.3	
SD700-3R3A	Single-phase 220	3.3	11.6	
SD700-5R5A	Single-phase/three-phase 220	5.5	16.5	B
SD700-7R6A	Single-phase/three-phase 220	7.6	22.8	
SD700-9R5A	Three-phase 220	9.5	23.8	C
SD700-120A	Three-phase 220	12.0	36.0	
SD700-160A	Three-phase 220	16.0	40.0	B
SD700-2R5D	Three-phase 400	2.5	7.5	
SD700-3R8D	Three-phase 400	3.8	11.4	C
SD700-6R0D	Three-phase 400	6.0	18.0	
SD700-8R4D	Three-phase 400	8.4	25.2	D
SD700-110D	Three-phase 400	11.0	27.5	
SD700-170D	Three-phase 400	17.0	42.5	E
SD700-240D	Three-phase 400	24.0	60.0	
SD700-300D	Three-phase 400	30.0	70.0	F
SD700-500D	Three-phase 400	50.0	115.0	
SD700-600D	Three-phase 400	60.0	120.0	F
SD700-700D	Three-phase 400	70.0	140.0	
SD700-800D	Three-phase 400	80.0	160.0	F
SD700-121D	Three-phase 400	120.0	240.0	

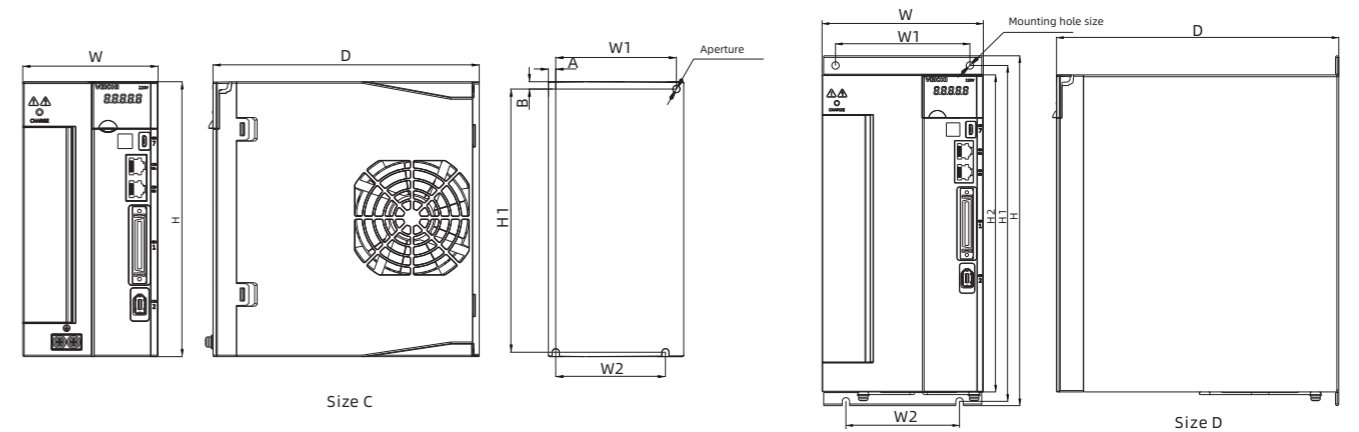

Case Type	Model	Overall Dimension(mm)			Installation Dimension (mm)						Aperture
		W	H	D	W1	W2	H1	H2	A	B	
C	SD700-120A-**-	92.5	188	182	82.5	75	180	\	5	5	3-M4
	SD700-160A-**-										
	SD700-6R0D-**-										
	SD700-8R4D-**-										
D	SD700-110D-**-	120	260	210	100	84.5	250	236	\	\	4-M5
	SD700-170D-**-										
	SD700-240D-**-										

Servo Motor Naming Rules

V7E - M 13 A - R85 15 - D 1 C

Product Series
V7E

Inertia Level
L: Low
M: Medium
H: High

Flange
04: 40mm 11: 110mm
06: 60mm 13: 130mm
08: 80mm 18: 180mm

Rated Voltage
A: 220V AC
D: 400V AC

Rated Power

Mark	Power (W)	Mark	Power (W)	Mark	Power (W)	Mark	Power (W)
R05	50	R75	750	1R5	1500	2R9	2900
R10	100	R85	850	1R8	1800	3R8	3800
R20	200	1R0	1000	2R0	2000	4R4	4400
R40	400	1R2	1200	2R3	2300	5R5	5500
R60	600	1R3	1300	2R6	2600	7R5	7500

Special motors for machine tools

	Axis Key	Brake	Oil Seal
1	●	X	●
2	●	●	●
3	●	X	X
4	●	●	X
5	X	X	●
6	X	●	●
7	X	X	X
8	X	●	X

Encoder Type
D: 23-bit integrated multi-turn absolute encoder
E: 24-bit integrated multi-turn absolute encoder
F: 24-bit split single-turn absolute encoder
Q: 17-bit single-turn absolute encoder

Rated Speed(RPM)
15:1500
20:2000
25:2500
30:3000

C Series Servo Motor

	60/80/110 Flange Motor Model									
Model V7E-	L06A-R4030-D□C	M06A-R4030-D□C	L08A-R7530-D□C	M08A-R7530-D□C	L08A-1R030-D□C	M08A-1R030-D□C	M11A-1R230-D□C	M11A-1R530-D□C	M11A-1R830-D□C	
Rated voltage (V)	220	220	220	220	220	220	220	220	220	220
Rated power (W)	400	400	750	750	1000	1000	1200	1500	1800	
Rated speed (RPM)	3000	3000	3000	3000	3000	3000	3000	3000	3000	3000
Max. speed (RPM)	6000	6000	6000	6000	5000	5000	5000	5000	5000	5000
Rated torque (N·m)	1.27	1.27	2.38	2.38	3.18	3.18	3.82	4.77	5.73	
Max. torque (N·m)	3.81	3.81	7.14	7.14	9.54	9.54	11.46	14.31	17.19	
Rated current (A)	2.6	2.6	4.6	4.6	4.8	4.8	6.3	7.6	9.3	
Max. current (A)	7.8	7.8	13.8	13.8	14.4	14.4	18.9	22.8	27.6	
Torquefactor (N·m/A)	0.49	0.49	0.52	0.52	0.66	0.66	0.61	0.63	0.62	
Moment of inertia (with brake) (kg.cm ²)	0.34 (0.36)	0.67 (0.69)	1.02 (1.13)	2.3 (2.41)	1.34 (1.45)	2.62 (2.73)	4.91 (5.52)	6.1 (6.71)	7.28 (7.89)	

	130 Flange Motor Model										
Model V7E-	M13A-1R020-D□C	M13D-1R020-D□C	H13A-R8515-D□C	H13D-R8515-D□C	M13A-1R120-D□C	M13D-1R120-D□C	M13A-1R520-D□C	M13D-1R520-D□C	H13A-1R315-D□C	H13D-1R315-D□C	M13A-1R720-D□C
Rated voltage (V)	220	380	220	380	220	380	220	380	220	380	220
Rated power (W)	1000	1000	850	850	1100	1100	1500	1500	1300	1300	1700
Rated speed (RPM)	2000	2000	1500	1500	2000	2000	2000	2000	1500	1500	2000
Max. speed (RPM)	3000	3000	3000	3000	4000	4000	3000	3000	3000	3000	4000
Rated torque (N·m)	4.78	4.78	5.41	5.41	5.25	5.25	7.16	7.16	8.28	8.28	8.12
Max. torque (N·m)	14.34	14.34	16.23	16.23	15.75	15.75	21.48	21.48	24.84	24.84	24.36
Rated current (A)	4.9	3.2	5.4	3.3	7	3.8	7.1	4.4	8.2	4.8	9.5
Max. current (A)	14.7	9.6	16.2	9.9	21	11.4	21.3	13.2	24.6	14.4	28.5
Torquefactor (N·m/A)	0.98	1.49	1.0	1.64	0.75	1.38	1.02	1.627	1.01	1.725	0.85
Moment of inertia (with brake) (kg.cm ²)	12.98 (15.12)	12.98 (15.12)	13.36 (15.5)	13.36 (15.5)	12.98 (15.12)	12.98 (15.12)	18.38 (20.52)	18.38 (20.52)	18.73 (20.78)	18.73 (20.78)	18.38 (20.52)

	130 Flange Motor Model											
Model V7E-	M13D-1R720-D□C	M13A-2R020-D□C	M13D-2R020-D□C	M13A-3R030-D1HC	H13A-1R815-D□C	H13D-1R815-D□C	M13D-3R630-D1HC	M13A-2R420-D□C	M13D-2R420-D□C	H13A-2R315-D□C	H13D-2R315-D□C	
Rated voltage (V)	380	220	380	220	220	380	380	220	380	220	380	
Rated power (W)	1700	2000	2000	3000	1800	1800	3600	2400	2400	2300	2300	
Rated speed (RPM)	2000	2000	2000	3000	1500	1500	3000	2000	2000	1500	1500	
Max. speed (RPM)	4000	3000	3000	5000	3000	3000	6000	4000	4000	2000	2000	
Rated torque (N·m)	8.12	9.55	9.55	9.55	11.46	11.46	11.46	11.46	11.46	14.64	14.64	
Max. torque (N·m)	24.36	28.65	28.65	28.65	34.38	34.38	34.38	34.38	34.38	43.92	43.92	
Rated current (A)	6	9.4	5.5	14.5	10.9	6.6	12	14.9	8.4	9.5	5.6	
Max. current (A)	18	28.2	16.5	43.5	32.7	19.8	36	44.7	25.2	28.5	16.8	
Torquefactor (N·m/A)	1.35	1.02	1.74	0.659	1.05	1.74	0.955	0.77	1.36	1.54	2.61	
Moment of inertia (with brake) (kg.cm ²)	18.38 (20.52)	25.58 (27.72)	25.58 (27.72)	25.58 (27.72)	26.6 (28.74)	26.6 (28.74)	36.38 (38.52)	25.58 (27.72)	25.58 (27.72)	36.38 (38.52)	36.38 (38.52)	

130/180 Flange Motor Model								
Model V7E-	H13A-2R315-D□C	H13D-2R315-D□C	M13A-3R120-D□C	M13D-3R120-D□C	M18A-2R915-D□C	M18D-2R915-D□LC	M18D-2R915-D□C	M18D-3R920-D□HC
Rated voltage (V)	220	380	220	380	220	380	380	380
Rated power (W)	2300	2300	3100	3100	2900	2900	2900	3900
Rated speed (RPM)	1500	1500	2000	2000	1500	1500	1500	2000
Max. speed (RPM)	3000	3000	4000	4000	3000	2000	3000	4000
Rated torque (N·m)	14.64	14.64	14.8	14.8	18.46	18.46	18.46	18.62
Max. torque (N·m)	43.92	43.92	44.4	44.4	46.15	46.15	46.15	46.55
Rated current (A)	14	8.4	16	11	16	7.1	10.7	13.2
Max. current (A)	42	25.2	48	33	40	17.75	26.75	33
Torque factor (N·m/A)	1.05	1.74	0.925	1.345	1.15	26	1.725	1.41
Moment of inertia (with brake) (kg·cm ²)	36.38 (38.52)	36.38 (38.52)	36.38 (38.52)	36.38 (38.52)	49.56 (50.05)	49.56 (50.05)	49.56 (50.05)	68.9 (75.39)

180 Flange Motor Model										
Model V7E-	M18D-4R415-D□LC	M18D-4R415-D□C	M18D-5R920-D□HC	M18D-5R515-D□LC	M18D-5R515-D□C	M18D-5R515-D□BC	M18D-7R520-D□HC	M18D-7R515-D□LC	M18D-7R515-D□C	M18D-7R515-D□BC
Rated voltage (V)	380	380	380	380	380	380	380	380	380	380
Rated power (W)	4400	4400	5900	5500	5500	5500	7500	7500	7500	7500
Rated speed (RPM)	1500	1500	2000	1500	1500	1500	2000	1500	1500	1500
Max. speed (RPM)	2000	3000	4000	2000	3000	3000	4000	2000	3000	3000
Rated torque (N·m)	28.01	28.01	28.17	35.02	35.02	35.02	35.81	47.75	47.75	47.75
Max. torque (N·m)	70	70	70.43	87.55	87.55	87.55	89.53	119.4	119.4	119.4
Rated current (A)	10.9	16.2	20	13.4	19	19	24.7	17	26	26
Max. current (A)	27.25	40.5	50	33.5	47.5	47.5	61.8	42.5	65	65
Torque factor (N·m/A)	2.57	1.729	1.41	2.61	1.84	1.84	1.45	2.81	1.84	1.84
Moment of inertia (with brake) (kg·cm ²)	68.9 (75.39)	68.9 (75.39)	110.11 (116.6)	110.11 (116.6)	110.11 (116.6)	110.11 (116.6)	156.6 (163.09)	156.6 (163.1)	156.6 (163.1)	156.6 (163.1)

C Series Servo Motor Installation Dimensions

60 flange

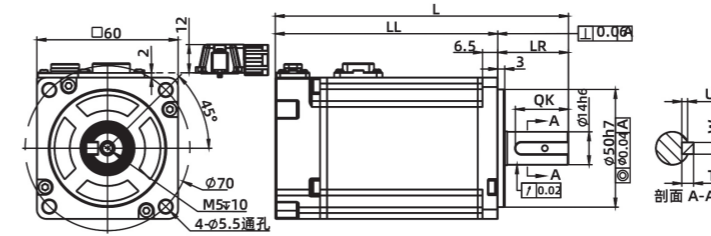

Unit: mm

Model	L	LL	LR	S	QK	U	W	T
V7E-L06A-R4030-D1C	124.5	94.5	30	14	22.5	2.5	5	5
V7E-L06A-R4030-D2C	155.5	125.5	30	14	22.5	2.5	5	5
V7E-M06A-R4030-D1C	135	105	30	14	22.5	2.5	5	5
V7E-M06A-R4030-D2C	165.5	135.5	30	14	22.5	2.5	5	5

80 flange

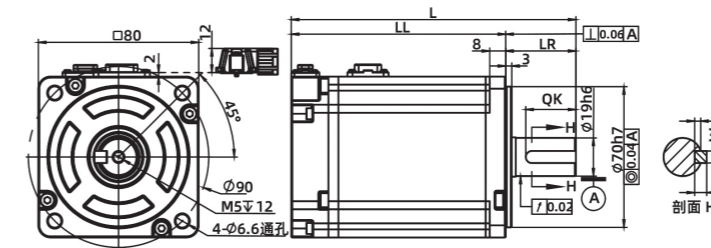

Unit: mm

Model	L	LL	LR	S	QK	U	W	T
V7E-L08A-R7530-D1C	142	107	35	19	25	3	6	6
V7E-L08A-R7530-D2C	174	139	35	19	25	3	6	6
V7E-M08A-R7530-D1C	152	117	35	19	25	3	6	6
V7E-M08A-R7530-D2C	184.5	149.5	35	19	25	3	6	6
V7E-L08A-1R030-D1C	156	121	35	19	25	3	6	6
V7E-L08A-1R030-D2C	188	153	35	19	25	3	6	6
V7E-L08M-1R030-D1C	166	131	35	19	25	3	6	6
V7E-L08M-1R030-D2C	198	163	35	19	25	3	6	6

110 flange

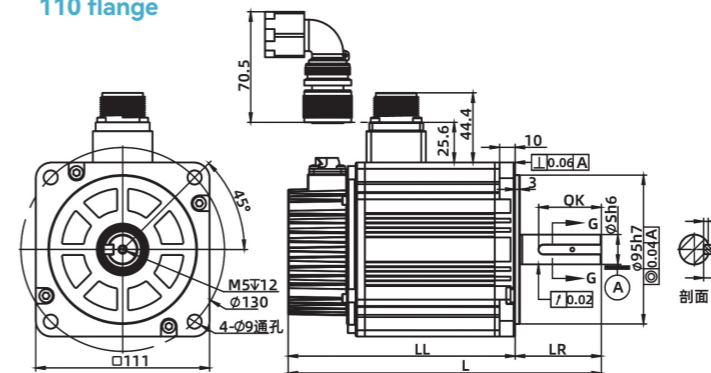

Unit: mm

Model	L	LL	LR	S	QK	U	W	T
V7E-M11A-1R230-D1C	190	135	55	19	40	3	6	6
V7E-M11A-1R230-D2C	221.2	166.2	55	19	40	3	6	6
V7E-M11A-1R530-D1C	200	145	55	19	40	3	6	6
V7E-M11A-1R530-D2C	231.2	176.2	55	19	40	3	6	6
V7E-M11A-1R830-D1C	210	155	55	19	40	3	6	6
V7E-M11A-1R830-D2C	241.2	186.2	55	19	40	3	6	6

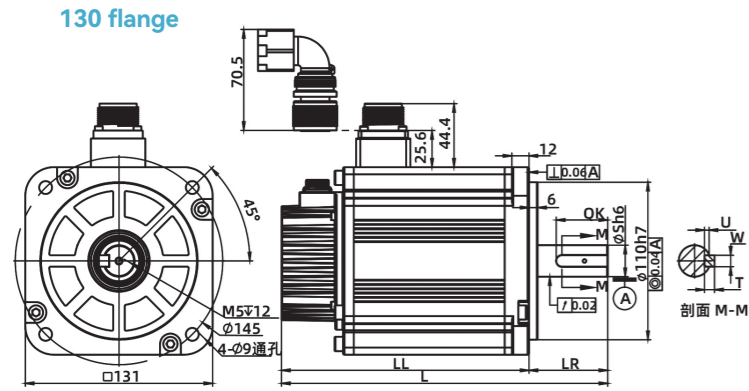

Unit: mm

Model	L	LL	LR	S	QK	U	W	T
V7E-M13□-1R020-D1C	193	138	55	22	36	3.2	8	7
V7E-M13□-1R020-D2C	221.2	166.2	55	22	36	3.2	8	7
V7E-H13□-R8515-D1C	198	143	55	22	36	3.2	8	7
V7E-H13□-R8515-D2C	226.2	171.2	55	22	36	3.2	8	7
V7E-M13□-1R120-D1C	193	138	55	22	36	3.2	8	7
V7E-M13□-1R120-D2C	221.2	166.2	55	22	36	3.2	8	7
V7E-M13□-1R520-D1C	208	153	55	22	36	3.2	8	7
V7E-M13□-1R520-D2C	236.2	181.2	55	22	36	3.2	8	7
V7E-H13□-1R315-D1C	214	159	55	22	36	3.2	8	7
V7E-H13□-1R315-D2C	242.2	187.2	55	22	36	3.2	8	7
V7E-M13□-1R720-D1C	208	153	55	22	36	3.2	8	7
V7E-M13□-1R720-D2C	236.2	181.2	55	22	36	3.2	8	7
V7E-M13□-2R020-D1C	228	173	55	22	36	3.2	8	7
V7E-M13□-2R020-D2C	256.2	201.2	55	22	36	3.2	8	7
V7E-M13A-3R030-D1HC	258	203	55	22	36	3.2	8	7
V7E-H13□-1R815-D1C	238	183	55	22	36	3.2	8	7
V7E-H13□-1R815-D2C	266.2	211.2	55	22	36	3.2	8	7
V7E-M13D-3R630-D1HC	258	203	55	22	36	3.2	8	7
V7E-M13□-2R420-D1C	228	173	55	22	36	3.2	8	7
V7E-M13□-2R420-D2C	256.2	201.2	55	22	36	3.2	8	7
V7E-H13□-2R315-D1LC	258	203	55	22	36	3.2	8	7
V7E-H13□-2R315-D2LC	286.2	231.2	55	22	36	3.2	8	7
V7E-M13□-3R120-D1C	258	203	55	22	36	3.2	8	7
V7E-M13□-3R120-D2C	286.2	231.2	55	22	36	3.2	8	7

Unit: mm

Model	L	LL	LR	S	QK	U	W	T
V7E-M18□-2R915-D1C	266	187	79	35	65	4.3	10	8
V7E-M18□-2R915-D2C	307.5	228.5	79	35	65	4.3	10	8
V7E-M18D-2R915-D1LC	266	187	79	35	65	4.3	10	8
V7E-M18D-2R915-D2LC	307.5	228.5	79	35	65	4.3	10	8
V7E-M18D-3R920-D1HC	290	211	79	35	65	4.3	10	8
V7E-M18D-3R920-D2HC	331.5	252.5	79	35	65	4.3	10	8
V7E-M18D-4R415-D1LC	290	211	79	35	65	4.3	10	8
V7E-M18D-4R415-D2LC	331.5	252.5	79	35	65	4.3	10	8
V7E-M18D-4R415-D1C	290	211	79	35	65	4.3	10	8
V7E-M18D-4R415-D2C	331.5	252.5	79	35	65	4.3	10	8
V7E-M18D-5R920-D1HC	325.5	246.5	79	35	65	4.3	10	8
V7E-M18D-5R920-D2HC	367	288	79	35	65	4.3	10	8
V7E-M18D-5R515-D1LC	325.5	246.5	79	35	65	4.3	10	8
V7E-M18D-5R515-D2LC	367	288	79	35	65	4.3	10	8
V7E-M18D-5R515-D1C	325.5	246.5	79	35	65	4.3	10	8
V7E-M18D-5R515-D2C	367	288	79	35	65	4.3	10	8
V7E-M18D-5R515-D1BC	325.5	246.5	113	42	96	4.2	12	10
V7E-M18D-5R515-D2BC	367	288	113	42	96	4.2	12	10
V7E-M18D-7R520-D1HC	372.5	293.5	79	35	65	4.3	10	8
V7E-M18D-7R520-D2HC	414	335	79	35	65	4.3	10	8
V7E-M18D-7R515-D1LC	372.5	293.5	79	35	65	4.3	10	8
V7E-M18D-7R515-D2LC	414	335	79	35	65	4.3	10	8
V7E-M18D-7R515-D1C	372.5	293.5	79	35	65	4.3	10	8
V7E-M18D-7R515-D2C	414	335	79	35	65	4.3	10	8
V7E-M18D-7R515-D1BC	372.5	293.5	113	42	96	4.2	12	10
V7E-M18D-7R515-D2BC	414	335	113	42	96	4.2	12	10

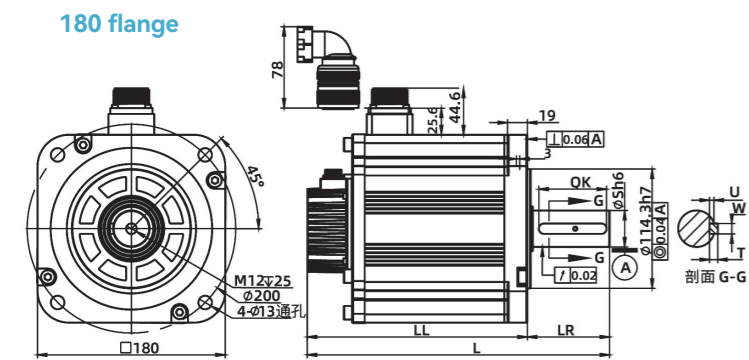

SD700 Series Servo Drive Cable

Power Cable Naming Rules

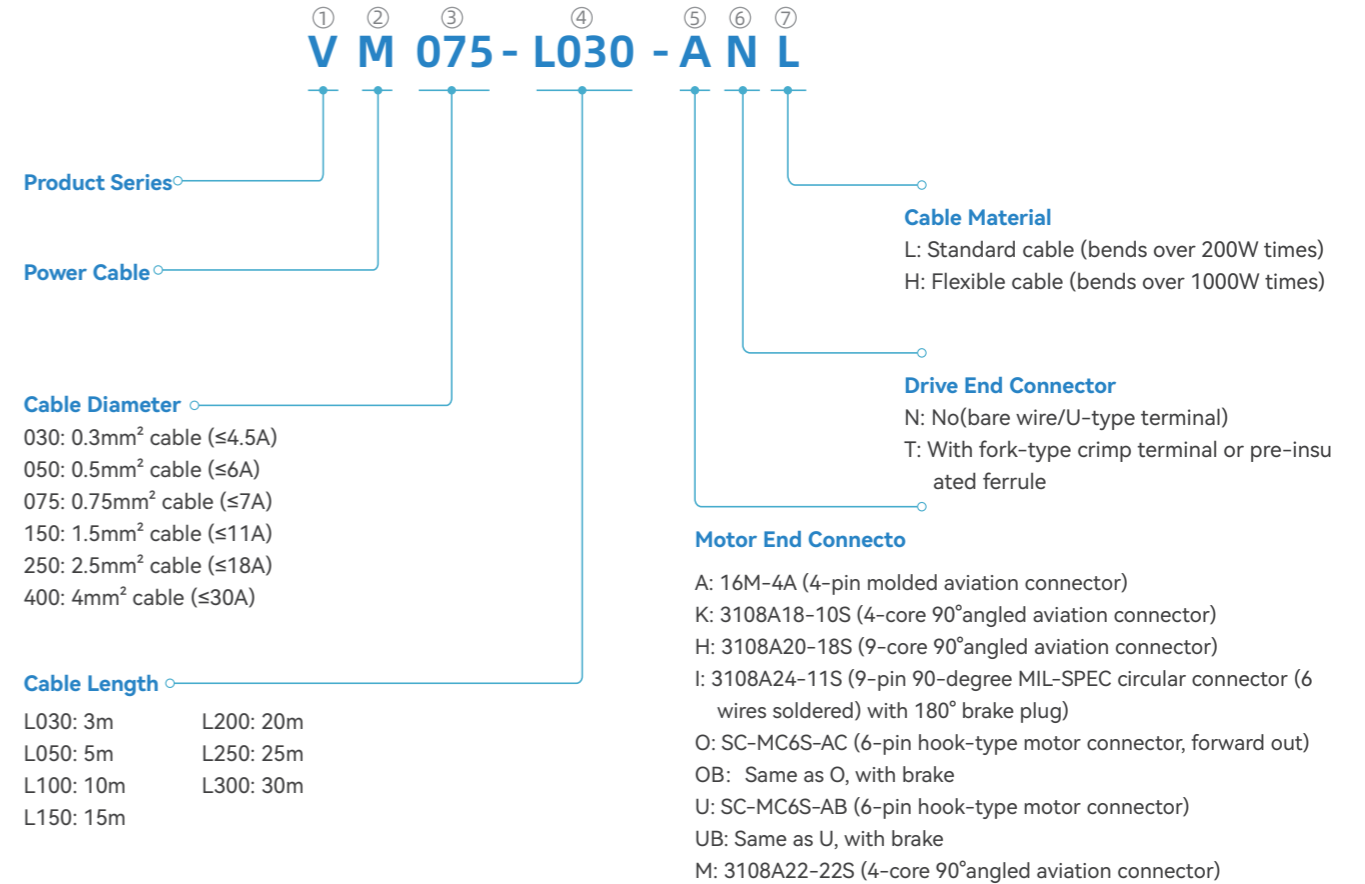

Motor Power Cables

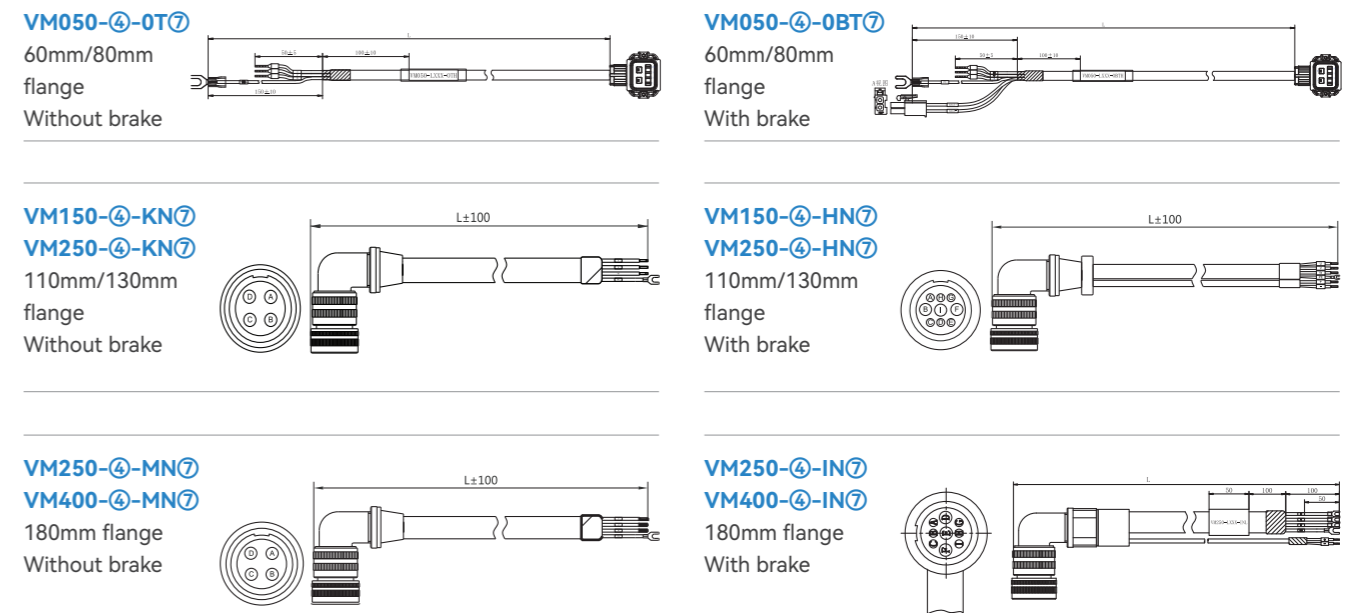

Encoder Cable Naming Rules

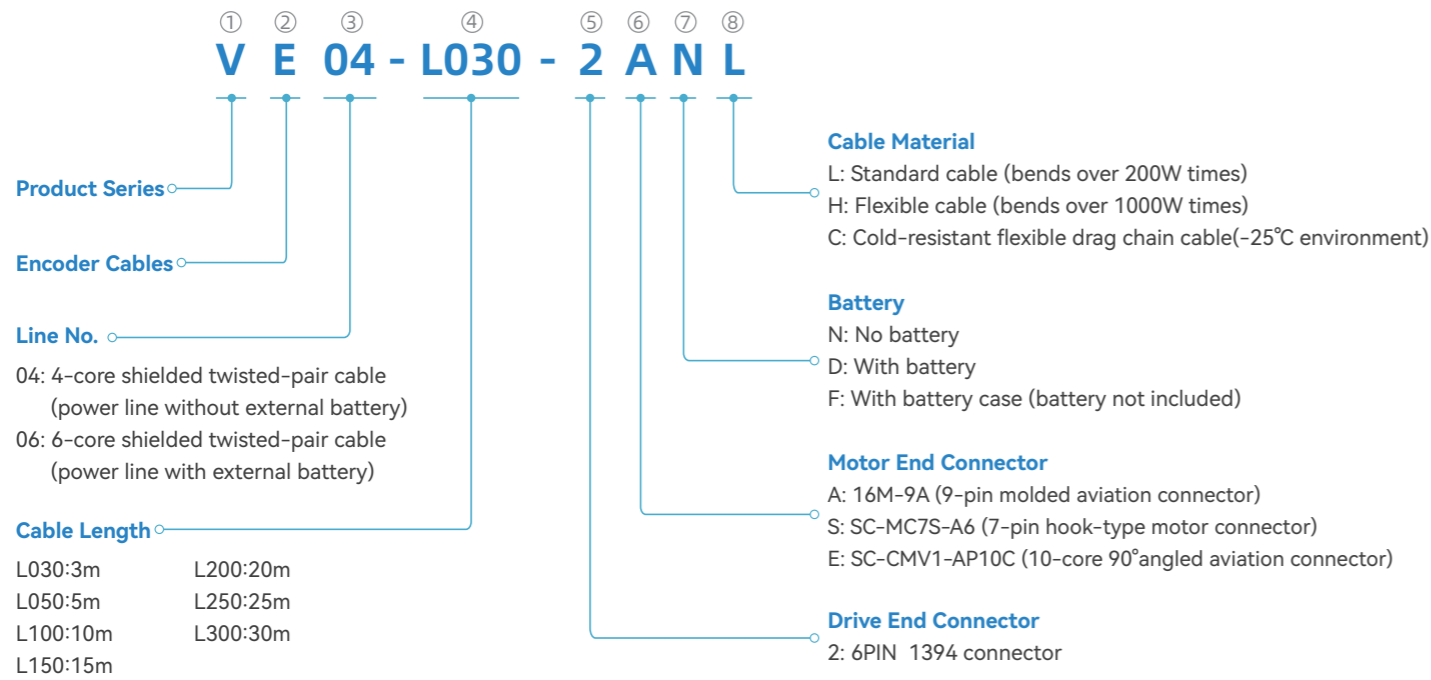

Note: When encoder wire ⑤⑥ defined as "2S" is longer than 15 meters, it is necessary to use the solution of encoder wire ⑤⑥ defined as "2A" plus adapter wire.

Encoder Cables

VE04-④-2SN⑧

40mm/60mm/
80mm flange
Without battery

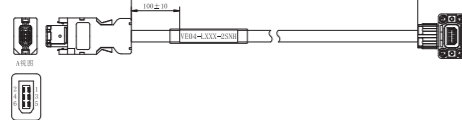

VE06-④-2SD⑧

40mm/60mm
/80mm flange
With battery

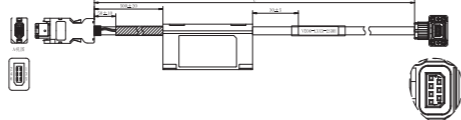

VE04-④-2EN⑧

110mm/130mm/
180mm flange
Without battery

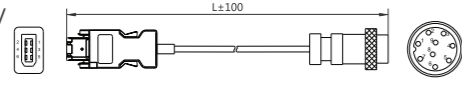

VE06-④-2ED⑧

110mm/130mm/
180mm flange
With battery

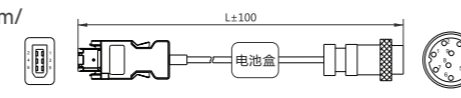

System Composition

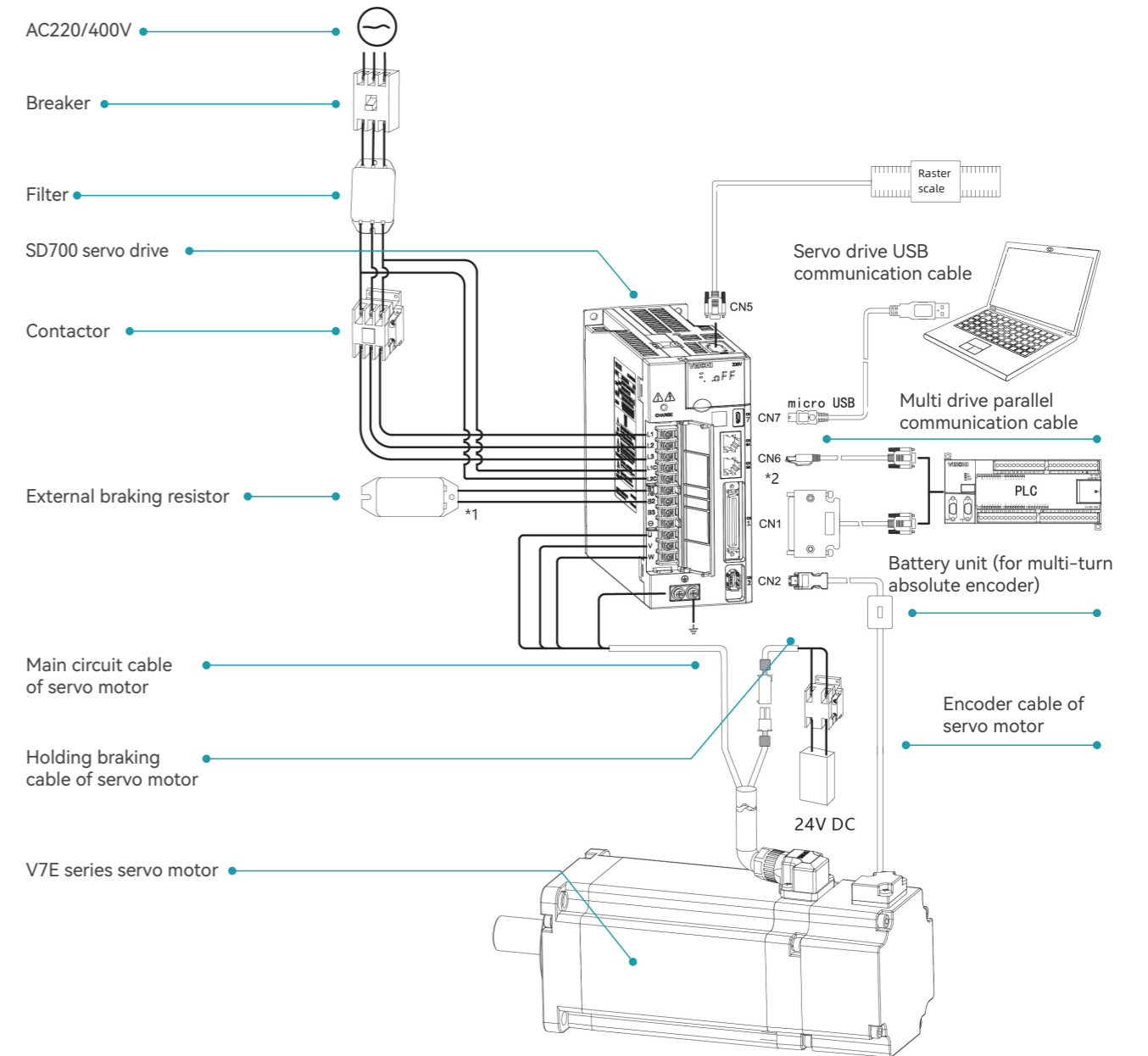



*1: When using the external braking resistor, please disconnect the short wire between B2-B3 terminals at first;

*2: CN6A and CN6B are two communication interfaces with the same pin definition, thus either is workable. The EtherCAT bus wiring must be set top in and bottom out.

SD500 Series Spindle Servo Drive





 Precise Speed and Position Control – Positioning accuracy within ± 1 pulse

 ARM+CPLD Architecture – Delivers superior performance for demanding applications

 Encoder Breakage Detection – Ensures system reliability

 Automatic Load Inertia Identification & Loop Parameter Auto-tuning – Optimized performance with minimal setup

 Full-Closed-Loop Vector Control – Dual encoder interfaces as standard

 Multi-Step Positioning & Rigid Tapping – Error within $\pm 2\%$

 Slim Book-Style Design – Saves installation space

 Independent Cooling Duct & Power Module Isolation – Enhances product reliability

Servo Drive Naming Rules

SD 500 - 5R5 D - P B

SD:
Servo drive products

500:
Spindle servo drive products

Rated Power

004: 4kW	018: 18kW
5R5: 5.5kW	022: 22kW
7R5: 7.5kW	030: 30kW
011: 11kW	037: 37kW
015: 15kW	

Encoder Type
B: Incremental encoder
Z: Sine-cos encoder

Drive Type
P: Pulse
E: EtherCAT
L: MECHATROLINK-III

Rated Voltage
D: 380V AC

Installation Dimensions

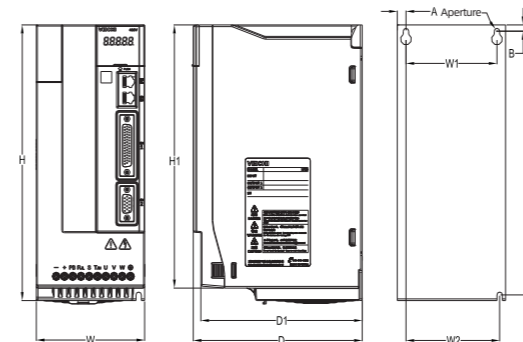

Model	Outer Dimension (mm)					Installation Dimensions (mm)					Aperture
	W	H	H1	D	D1	W1	W2	H2	A	B	
SD500-004D-*	100	242	231	156	149	84	86.5	231.5	8	5.5	3-M4
SD500-5R5D-*											
SD500-7R5D-*	116	320	307.5	176	169	98	100	307.5	9	6	3-M5
SD500-011D-*											

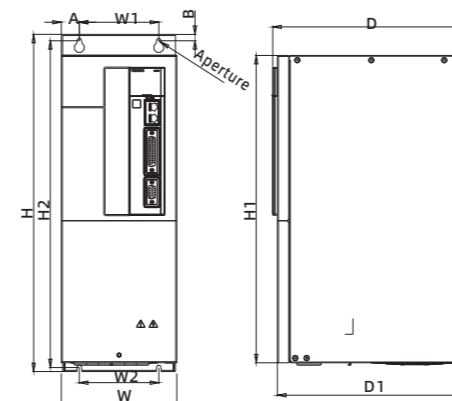

Model	Outer Dimension (mm)					Installation Dimensions (mm)					Aperture
	W	H	H1	D	D1	W1	W2	H2	A	B	
SD500-015D-*	145	424.5	387	242	/	100	100	411.5	23	8	4-M5
SD500-018D-*											
SD500-022D-*	185	471	433	242	/	140	140	457	22	8.75	4-M6
SD500-030D-*											
SD500-037D-*											

Models

Model	Input Power	Rated Current (A)	Motor (kW)	Brake Unit	Resistor (Ω /kW)
SD500-004D-	Three-phase 380V 50/60Hz	10	4	Built-in	50/1.0
SD500-5R5D-		13	5.5		50/1.0
SD500-7R5D-		17	7.5		45/1.5
SD500-011D-		25	11		35/2.0
SD500-015D-		32	15		30/3.0
SD500-018D-		38	18		30/3.0
SD500-022D-		45	22		25/4.0
SD500-030D-		60	30		18/6.0
SD500-037D-		75	37		18/7.0

Servo Motor Naming Rules

CM 2 S - 1560 D 004 - U2 28 N 3

Product Series
Spindle motor

Motor Base
A: 130 2: 200
0: 165 4: 265
1: 180 6: 360

Frame Size
S,M,L,H,E,F

Reference Speed/Maximum Speed
1560: 1500/6000rpm
20A0: 2000/10000rpm

Rated Voltage
D: 380V

Installation Method

3: Horizontal mounting
5: Vertical mounting
7: Horizontal/Vertical mounting

Axis Extension

K: Keyed
N: Not keyed

Axis Diameter

28: 28mm
38: 38mm

Encoder Type

N0: No encoder
U1: Incremental encoder 1024 lines
U2: Incremental encoder 2500 lines
Z1: Sine-cosine encoder 1024 lines

Rated Power

2R2: 2.2kW	015: 15kW
004: 4kW	018: 18kW
5R5: 5.5kW	022: 22kW
7R5: 7.5kW	030: 30kW
011: 11kW	037: 37kW

Motor Specification and Installation Dimensions

Model	Rated Power kW	Speed r/min	Voltage V	Current A	Torque N·m	Inertia kgm ²	Frame No.	L (mm)	L1 (mm)	L2 (mm)	D (mm)	F (mm)	G (mm)
	Continuous rating	Reference/ max. speed	Reference volt.	Continuous rating	Continuous rating								
CM0M-1560D2R2-	2.2	1500/6000	380	5.1	14	0.0077	165	335	95	112	28	-	-
CM0L-1560D004-	4	1500/6000	380	8.8	25.5	0.0116		385	140	159	28	-	-
CM0H-1560D5R5-	5.5	1500/6000	380	12.2	35	0.0162		445	200	219	28	-	-
CM1S-1560D2R2-	2.2	1500/6000	380	5	14	0.0071	180	334	65	-	28	-	-
CM1M-1560D004-	4	1500/6000	380	7.7	25.5	0.0101		369	100	-	28	-	-
CM1L-1560D5R5-	5.5	1500/6000	380	11.9	35	0.0151		419	150	-	28	-	-
CM2S-1560D004-	4	1500/6000	380	8.2	25.5	0.0128	200	375	109	-	38	-	-
CM2M-1560D5R5-	5.5	1500/6000	380	11.7	35	0.0169		405	139	-	38	-	-
CM2L-1560D7R5-	7.5	1500/6000	380	15.4	48	0.0236		455	189	-	38	-	-
CM2H-1560D011-	11	1500/6000	380	22.7	70	0.0303	265	505	239	-	38	-	-
CM4S-1560D011-	11	1500/6000	380	21.6	70	0.0605		482	133	-	42	12	45
CM4M-1560D015-	15	1500/6000	380	29.1	96	0.0791		510	173	-	42	12	45
CM4L-1560D018-	18.5	1500/6000	380	35.7	118	0.0954	265	545	208	-	55	16	59
CM4H-1560D022-	22	1500/6000	380	42	140	0.1117		580	243	-	55	16	59
CM4F-1560D030-	30	1500/6000	380	56.5	191	0.1676		700	363	174	55	16	59

CM0M,0L,0H Series Specification and Installation Dimensions

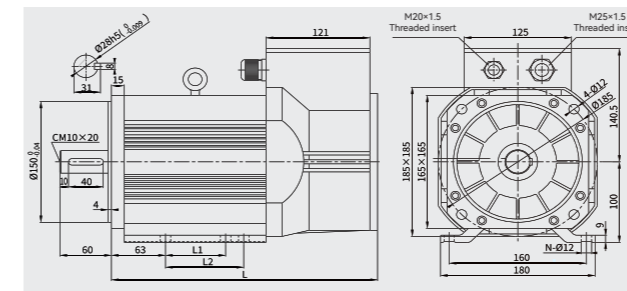

CM1S,1M,1L Series Specification and Installation Dimensions

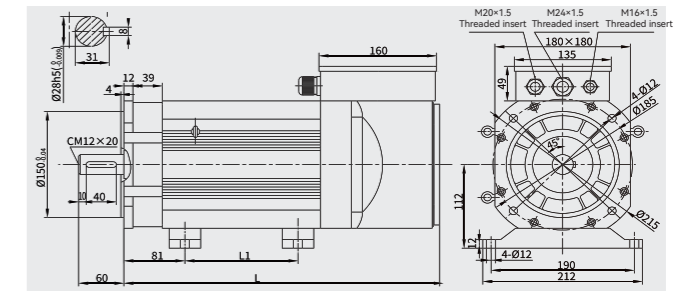

CM2S,2M,2L,2H Series Specification and Installation Dimensions

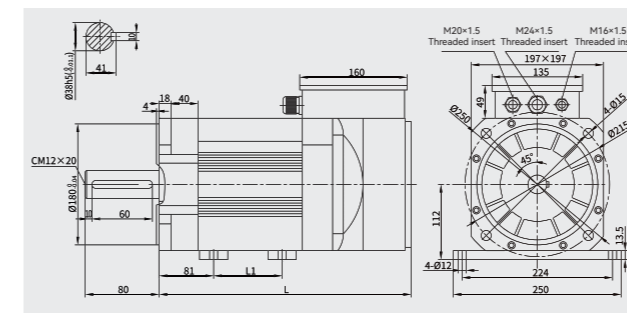

CM4S,4M,4L,4H,4F Series Specification and Installation Dimensions

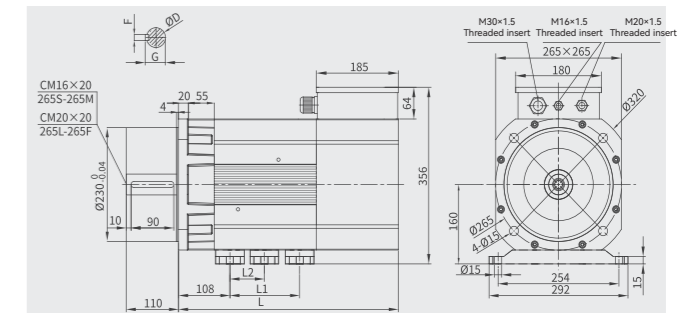

Pulse Wiring

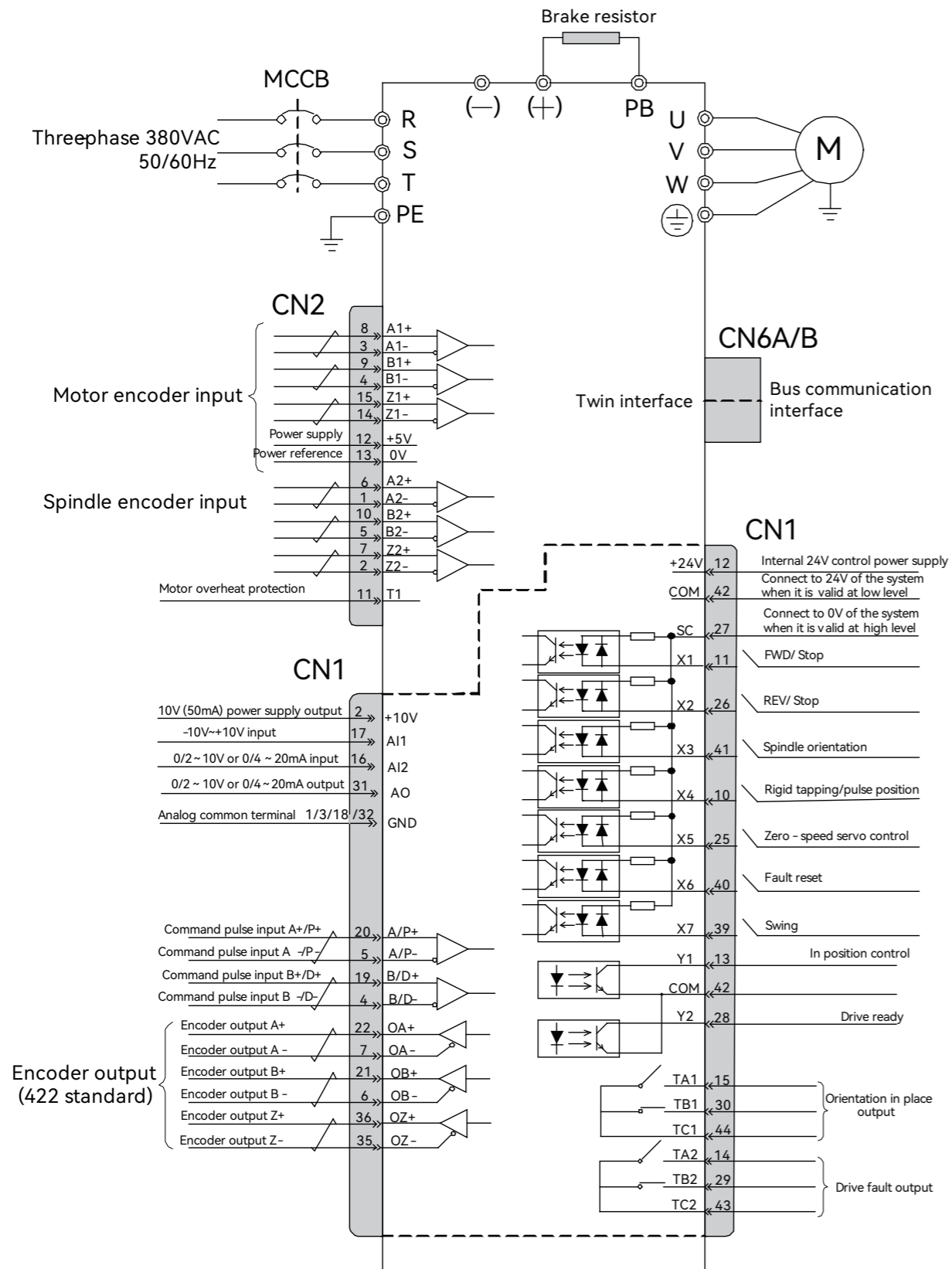

Service & Scope

Pioneering Technology , Unmatched Service

VEICHI Electric has established an integrated global service network through its innovative "Region + Industry" marketing strategy, which synergizes cross-sector resources and distribution channels to deliver comprehensive solutions. With permanent business and technical support teams strategically located across 21 major Chinese cities and overseas operations including Indian subsidiaries, the company is supported by an extensive network of 313 domestic and international distributors that ensure seamless market coverage. By consistently delivering superior product quality backed by professional technical support and service excellence, VEICHI Electric continues to enhance its global brand reputation while driving sustainable international growth through reliable, customer-centric solutions.

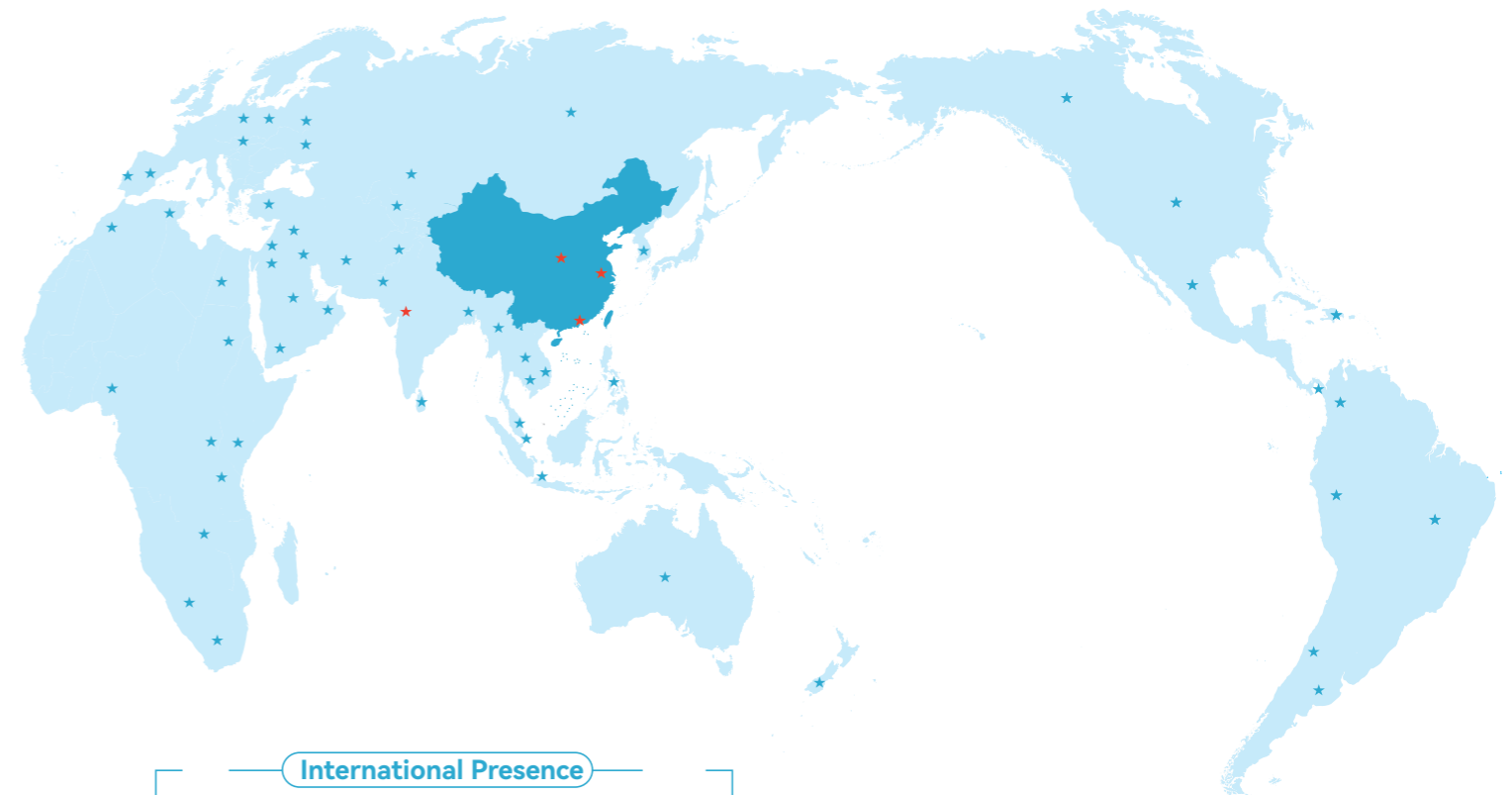

International Presence

Offices/service centers in South-East Asia, South Asia, CIS, Middle East, Europe, Africa and the Americas

China Coverage

21 local service centers nationwide, 22 provinces/municipalities and Hong Kong/Macau/Taiwan covered distribution network



21 domestic stations



6 overseas offices



300+ dealers