

VC Series PLC



VEICHI

Suzhou VEICHI Electric Co., Ltd
No.1000 Songjia Road, Guoxiang street, Wuzhong Economic
and Technological Development Zone, Suzhou

Tel: +86-512-6617 1988 Fax: +86-512-6617 3610
Facebook: <https://www.facebook.com/veichigroup>
Whatsapp: +86- 138 2881 8903
<https://www.veichi.com/>



Official Website
*Version:2023 V1.2
VEICHI Electric Co., Ltd all rights reserved,
subject to change without notice.

About us

Veichi (stock code: 688698) has always committed to electric drive and industrial control since its foundation. As an all-round company engaged in R & D, manufacturing and sales on high-tech industrial automation products, Veichi has been identified with several honorary titles such as the third patch of Specialized and Sophisticated Enterprises That Produce New and Unique Products, New and High-tech Enterprise, Jiangsu Engineering Technology Research Center, Jiangsu Provincial-level Enterprise Technology Center, Jiangsu Private-own Technical Enterprise, and has obtained the highest level of enterprise credit. Through years of independent research and development, Veichi now has been authorized with patents totaling 163 by the end of June, 2023, and among them 43 are for invention.

Having established R & D center and manufacturing bases in Suzhou, Shenzhen and Xi'an, added with the wholly-owned subsidiary in India, Veichi now are dealing with customers from several nations and regions and has the full capability to provide safe, competitive and trustworthy products and services to customers from the larger world.

Veichi provides various products including AC drive, servo

system, and control system, which are applied in all sorts of fields like heavy industry, mining, petroleum and petrochemical, machine tools, hydraulic transmission, photovoltaic pumping, high-efficiency energy, robotics, printing and packaging, textile, new energy, medical and many other industries

20 service stations and 211 contracted distributors cover 31 provinces on China mainland and Hong Kong, Macao and Taiwan regions, which guarantees a massive and efficient network for sales and services for our customers.

Veichi will continue to abide by the operation philosophy, that is, guided by market demand and driven by technological innovation, enlarge and enhance its core business like AC drive, servo system, control system and SIoT. And Veichi will always be devoted to providing quality products and services for customers and further make contributions to the development of electric drive and industrial control.

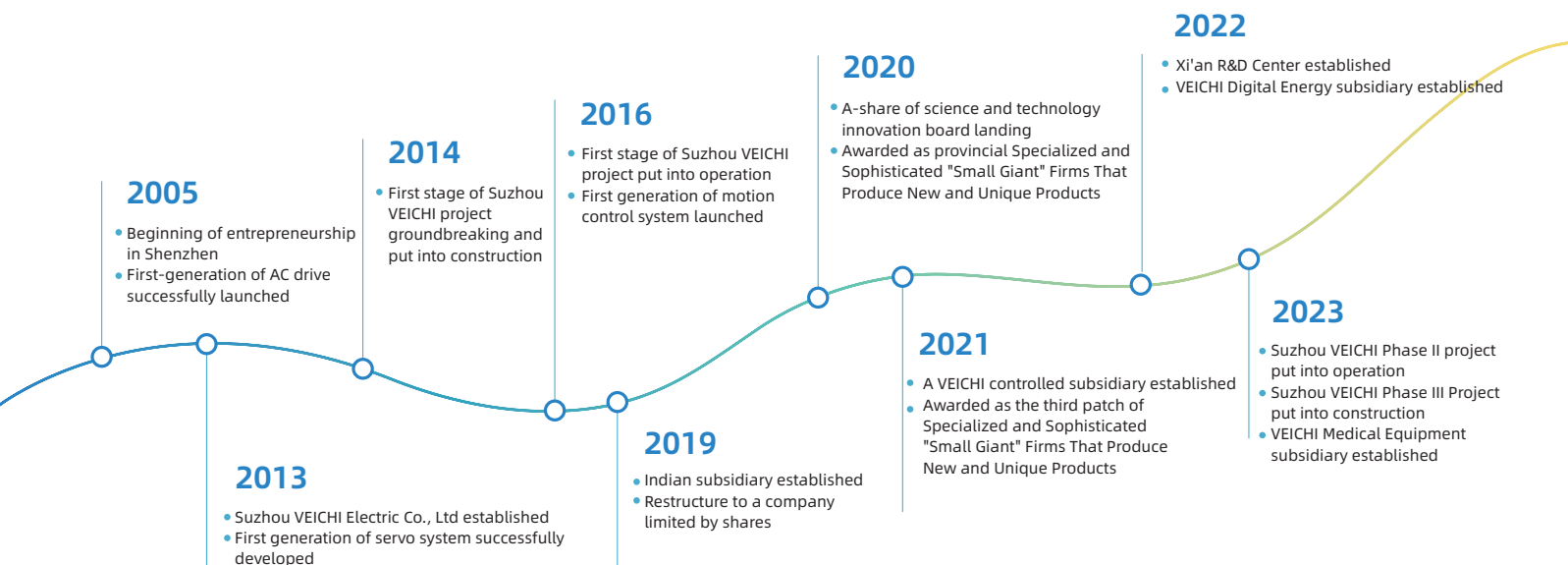

PLC series product planning

VEICHI PLC is divided into several series of single module type, general-purpose type, bus-type, high-performance type, motion control type and industrial Ethernet type.

- VC1 and VC1S are designed for the high cost-effective applications of logic control below three pulses;
- VC2 is designed for applications based on the CANopen bus control;
- VC3 is designed for applications of multi-channel pulse control;
- VC3M is designed for the pulse-based motion control;
- VC5 is designed for industrial Ethernet applications based on the EtherCAT protocol.

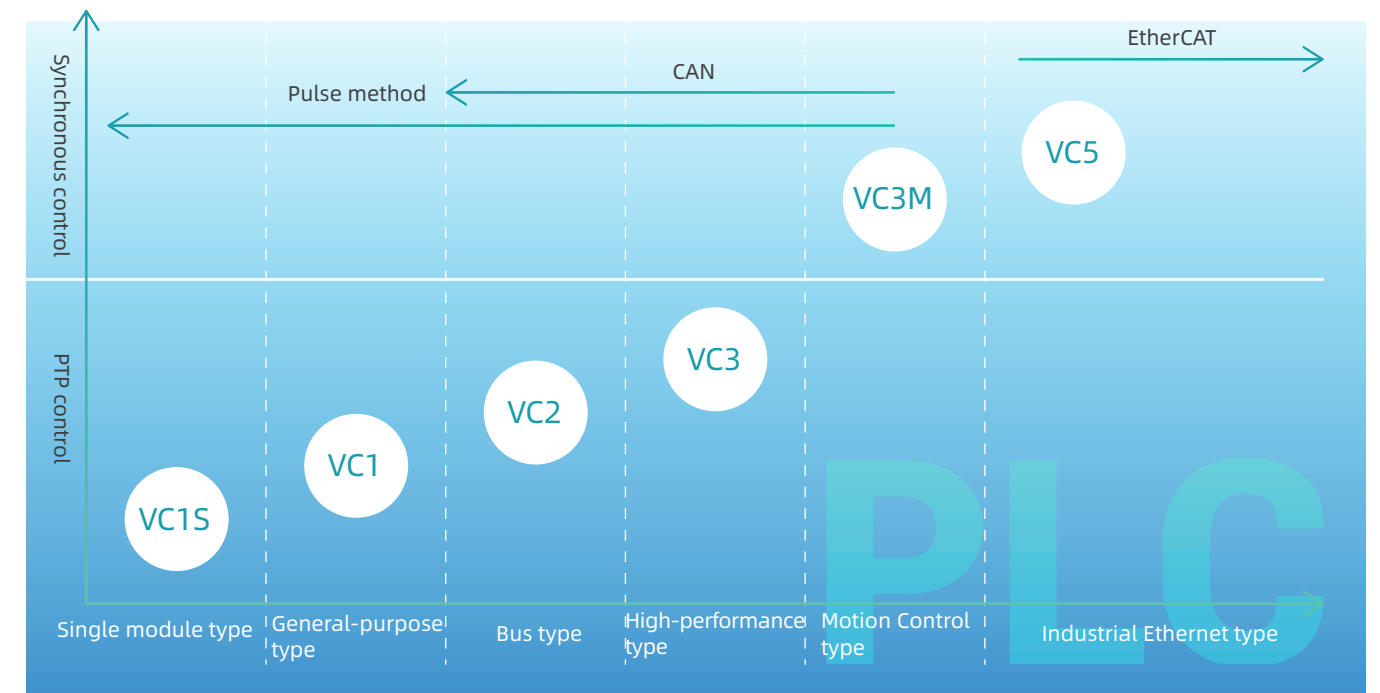
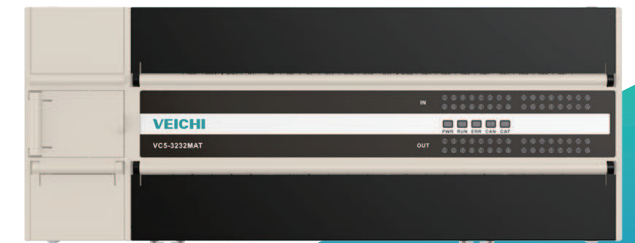

Veichi industrial automation control system solutions

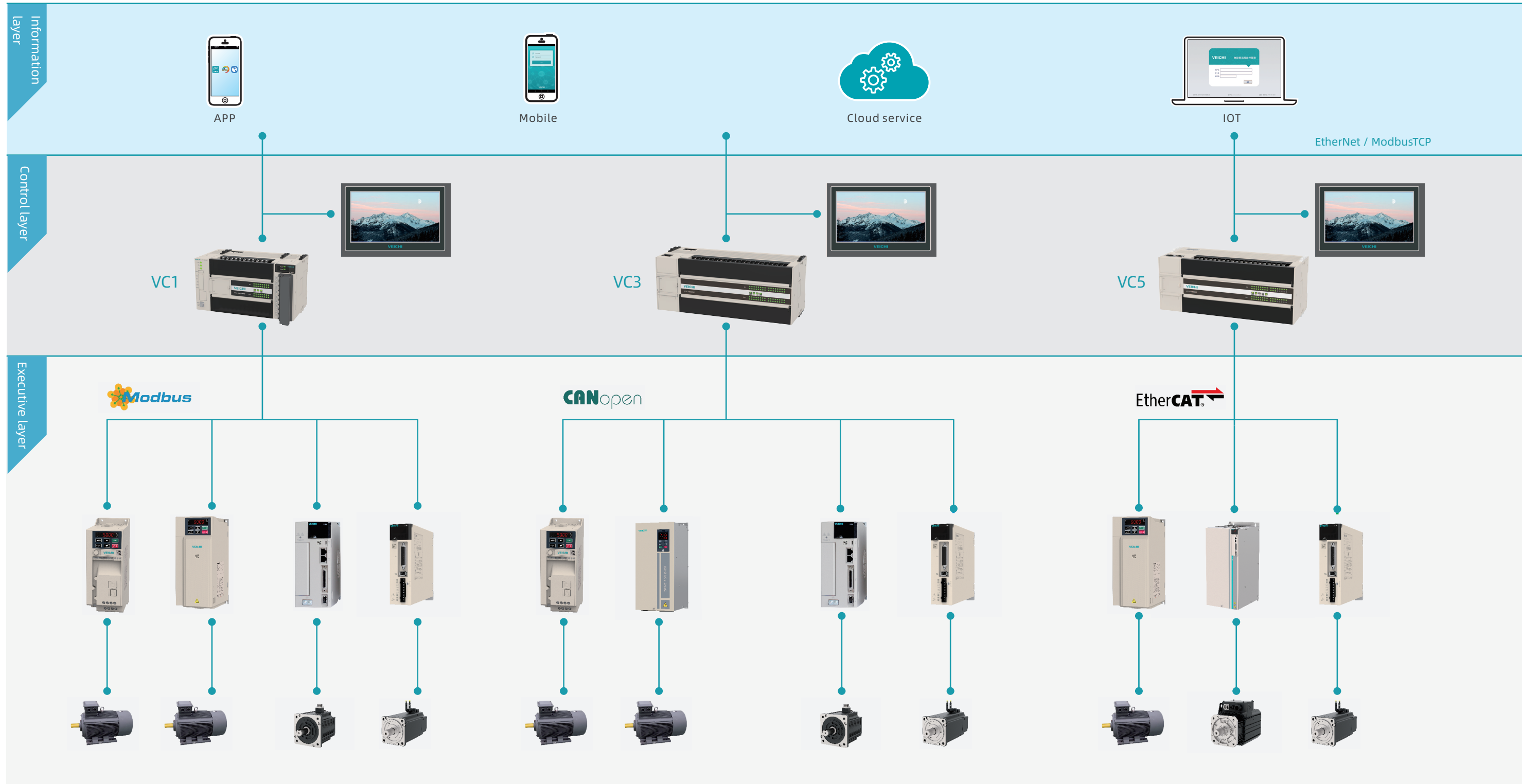

VC series main module & IO expansion module naming rules

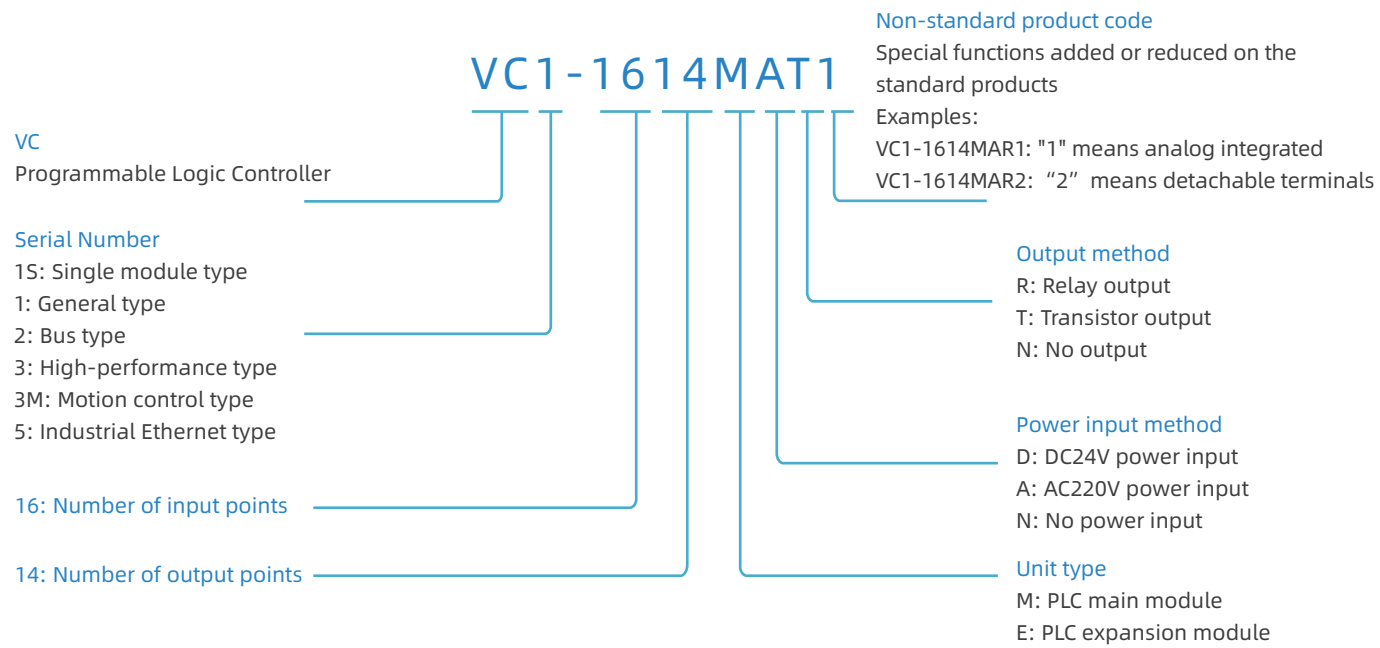

VC1 series PLC port introduction

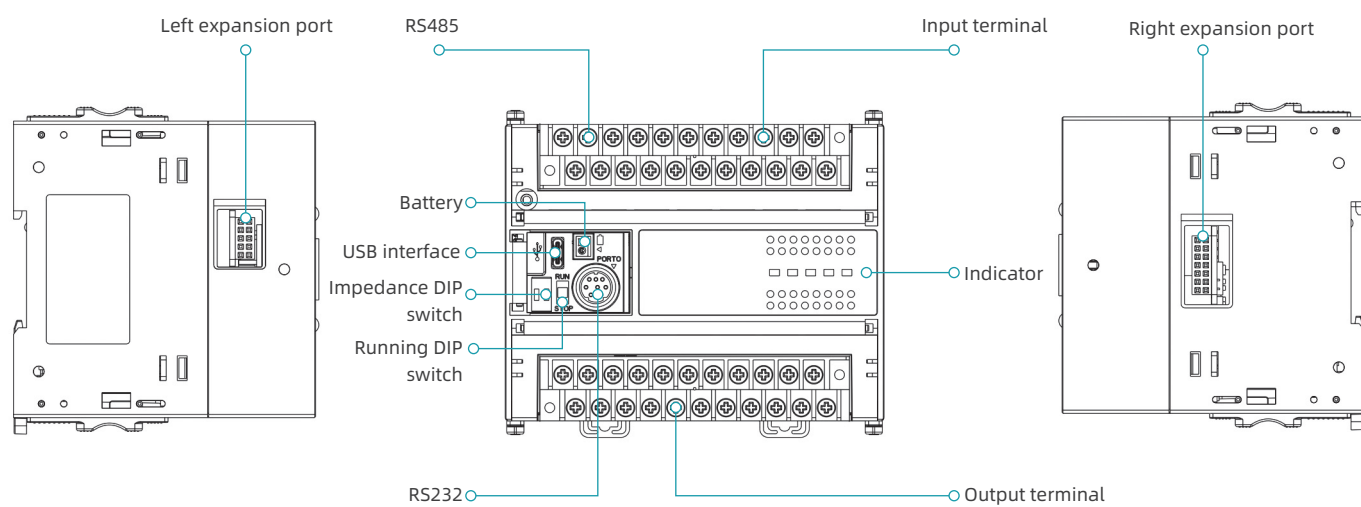

VC1S Series PLC

The VC1S series PLC is a single module PLC with a streamlined mechanism that can perform logic control and data operations, etc., with rich basic functions and excellent cost performance.

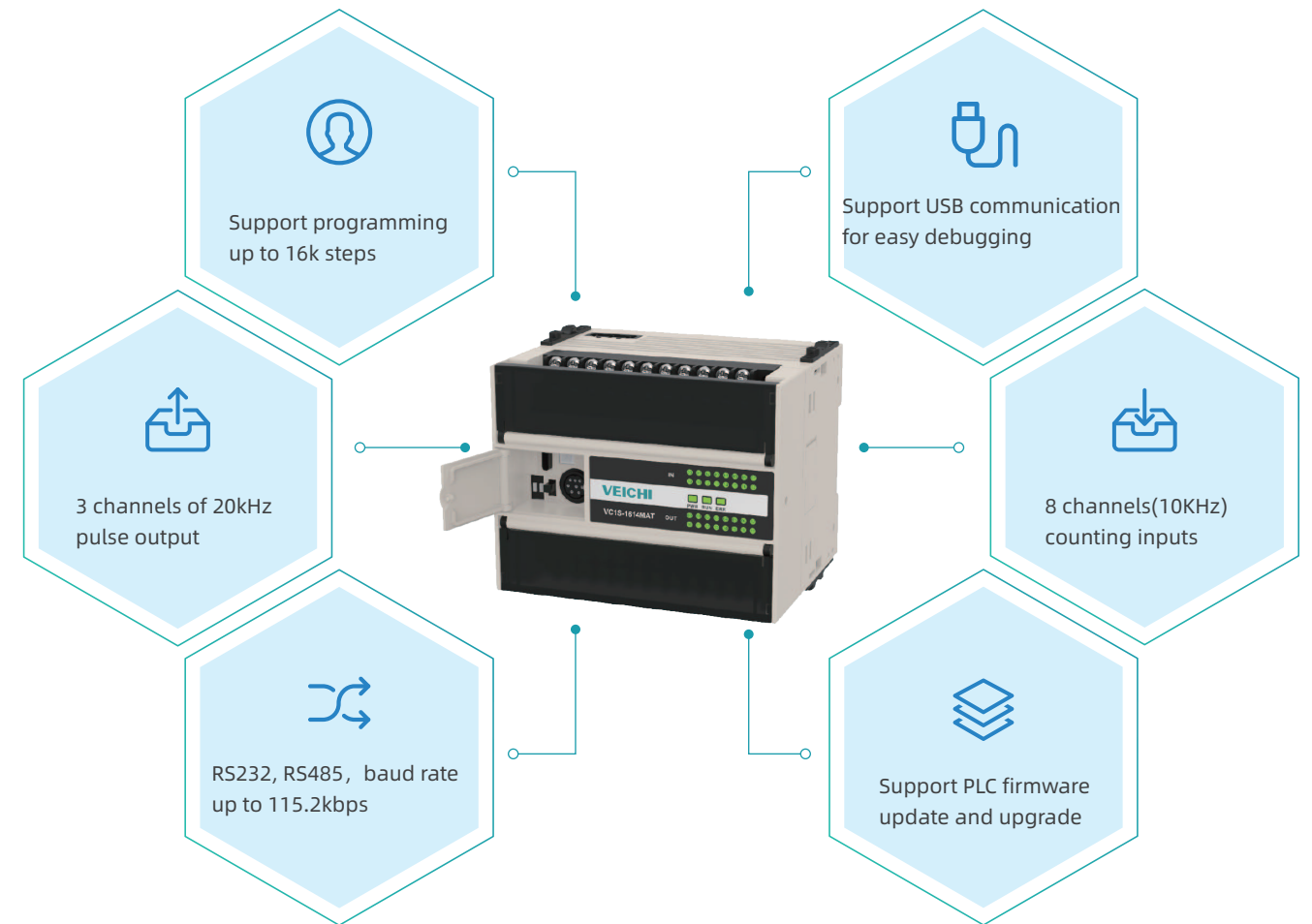

High-speed counter

- 8 pulse counters, support 8 counter interrupts
- Support single-phase, dual-phase (Up/Down), AB-phase (1X and 4X) counters counting frequency of 5-10KHz

High-speed pulse output

- 3 channels of 20KHz pulse output, channels Y0,Y1,Y2 respectively
- Software provides PLS (PWM or PTO), positioning control command, etc.

Serial communication port

- The body provides one RS232 and one RS485 serial communication port, named COM0 and COM1 respectively, with a maximum communication rate of 115.2K.
- COM0 port can be used as a programming port and also supports Modbus RTU slave protocol.
- COM1 port supports Modbus RTU master and slave protocols, free communication, N:N protocol, built-in termination resistor, and dialable code

USB programming port

- Support USB2.0, compatible with common Type-C USB phone data cable

VC1S series product specifications

Index		Specifications
Communication	Port	2 asynchronous serial communication ports: communication port 0: RS232; communication port 1: RS485; 1 way USB interface
	Communications Baud Rate	1.2kbps~115.2kbps
	Communication protocols	Modbus communication protocol, free port protocol, N:N (VEICHI-specific protocol)
	USB communication	USB2.0, Type-C interface, support program upload and download, monitoring, firmware upgrade
Digital input and output characteristics	Type of input	Source type, drain type
	Rated voltage	DC24V, 4mA
	Logic 1 [Voltage Range]	18~30VDC
	Logic 0 [Voltage Range]	0~4VDC
	Input Filter	8 input points. Software could set the filtering time and the subsequent points use hardware filtering, the filtering constant is 10ms
	Allowable leakage current [max]	1mA
	Isolation	Photoelectric isolation, 500VAC, 1 min
	High-speed counter	Single-phase 8 channels with maximum input frequency of 10 kHz Dual-phase 4 channels with maximum input frequency of 5KHz
	Maximum pulse output (transistor)	3-channel 100KHz pulse output
	General Features	Basic instruction execution time
Real-time clock		No support
Max. I/O points		Stand-alone
Max. expansion module		No support
Power down save soft components		FLASH permanent preservation, maximum 2K word components
Program power-down hold		Support, power down permanent storage

VC1S series selection table

Product Model	Digital port (DI/DO)	Removable terminals	Output Type	Power supply	Dimension (unit mm) (L*W*H)	Certification
VC1S-0808MAR	8DI/8DO	X	Relay	220VAC	115*90*92.7	CE
VC1S-0808MAT	8DI/8DO	X	Transistor	220VAC	115*90*92.7	CE
VC1S-1212MAR	12DI/12DO	X	Relay	220VAC	115*90*92.7	CE
VC1S-1212MAT	12DI/12DO	X	Transistor	220VAC	115*90*92.7	CE
VC1S-1614MAR	16DI/14DO	X	Relay	220VAC	115*90*92.7	CE
VC1S-1614MAT	16DI/14DO	X	Transistor	220VAC	115*90*92.7	CE
VC1S-2820MAR	28DI/20DO	X	Relay	220VAC	192.5*90*92.7	CE
VC1S-2820MAT	28DI/20DO	X	Transistor	220VAC	192.5*90*92.7	CE
VC1S-3624MAR	36DI/24DO	X	Relay	220VAC	192.5*90*92.7	CE
VC1S-3624MAT	36DI/24DO	X	Transistor	220VAC	192.5*90*92.7	CE

VC1 Series PLC

The VC1 series PLC is a general-purpose PLC with small structure, powerful functions and extremely high cost performance. It can be widely used in machine manufacturing industries such as CNC machine, textiles, packaging, plastic steel, air conditioners, elevators, printing and so on.

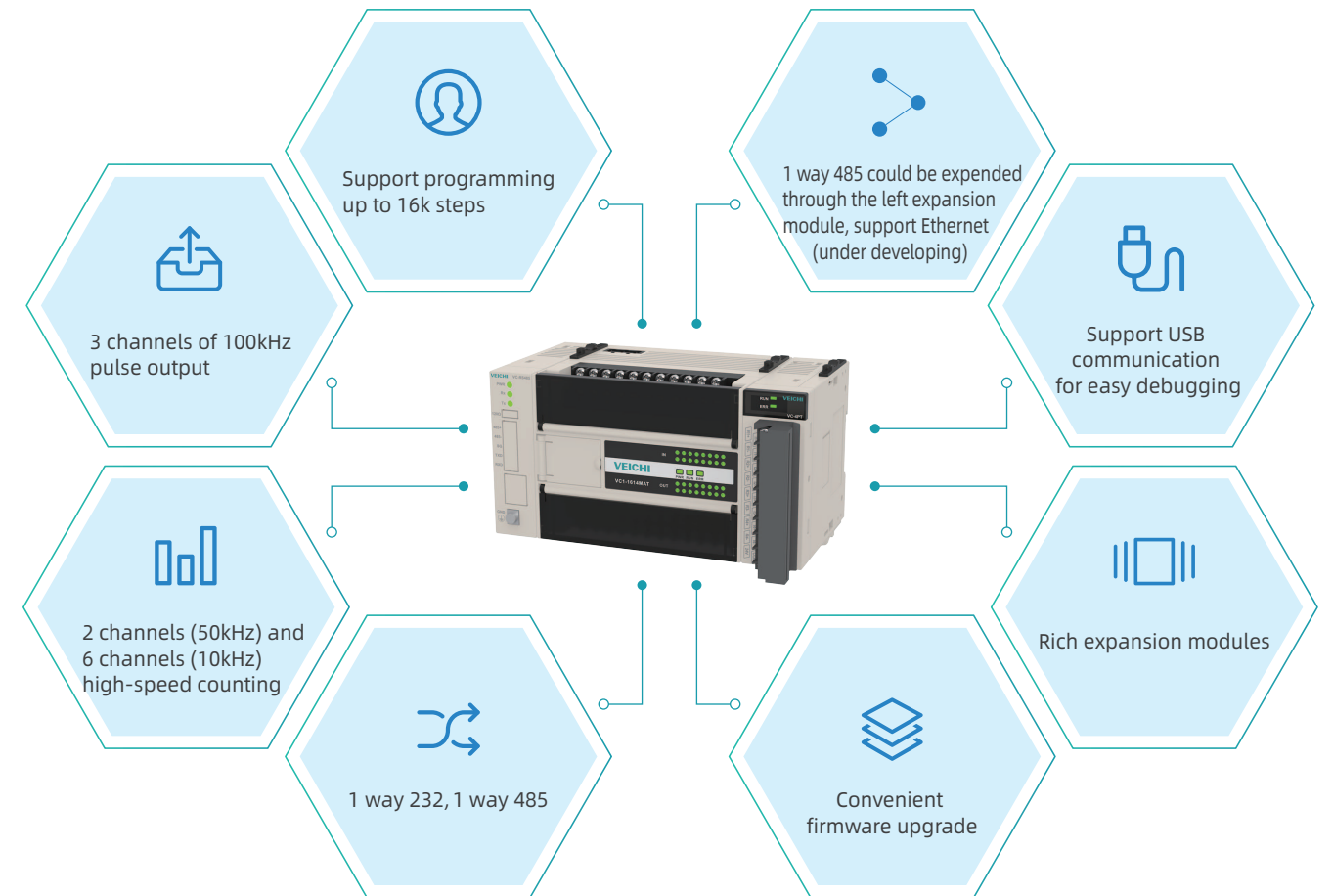

8-channel high-speed counter

- Single-phase supports 8 channels with maximum frequency of 50KHz, dual-phase supports 4 channels with maximum frequency of 25KHz
 - Support single-phase, dual-phase (Up/Down), AB-phase (1X frequency and 4X frequency) counting method
- Provides 3 high speed pulse outputs**
- Provides 3 high speed pulse outputs
 - Output frequency of 100KHz
 - Supports positioning control command groups for simple motion control applications

USB programming port

- Support USB2.0, compatible with common TYPE-C USB phone data cable

Serial communication port

- The body provides one RS232 and one RS485 serial communication port, named COM0 and COM1 respectively, with a maximum communication rate of 115.2K.
- COM0 port can be used as a programming port and also supports Modbus RTU slave protocol.
- COM1 supports Modbus RTU master and slave protocols, free communication, N:N protocol, built-in termination resistor, dialable code

Left Expansion Module

- Expansion module for 1 RS485 communication port, named COM2, supports Modbus RTU master and slave protocols, free communication, VEICHI's own N:N protocol, providing a more cost-effective solution for more applications

VC1 series product specifications

Index		Specifications
Communication	Ports	2 asynchronous serial communication ports: communication port 0: RS232; communication port 1: RS485; 1 way USB interface
	Communications Baud Rate	1.2kbps~115.2kbps
	Communication protocols	Modbus communication protocol, free port protocol, N:N (VEICHI-specific protocol)
	USB communication	USB2.0, Type-C interface, support program upload and download, monitoring, firmware upgrade
Digital input and output characteristics	Type of input	Source type, drain type
	Rated voltage	DC24V, 4mA
	Logic 1 [Voltage Range]	18~30VDC
	Logic 0 [Voltage Range]	0~4VDC
	Input Filter	8 input points. Software could set the filtering time and the subsequent points use hardware filtering, the filtering constant is 10ms
	Allowable leakage current [max]	1mA
	Isolation	Photoelectric isolation, 500VAC, 1 min
	High-speed counter	Single-phase 50KHz [2pcs], 10KHz [6pcs] Dual-phase 25KHz [1pcs], 5KHz [3 pcs]
	Maximum pulse output (transistor)	3-channel 20KHz pulse output
	General Features	Basic instruction execution time
Real-time clock		±45 sec/month (room temperature)
Max. I/O points		128
Max. expansion module		15 (max. 8 functional modules)
Power down save soft components		FLASH permanent preservation, maximum 2K word components
Clock		Support
Program power-down hold		Support, power down permanent storage

VC1 series selection table

Product Model	Digital port (DI/DO)	Removable terminals	Output Type	Power supply	Dimension (unit mm) (L*W*H)	Certification
VC1-0806MAR	8DI/6DO	X	Relay	220VAC	115*90*92.7	CE
VC1-0806MAT	8DI/6DO	X	Transistor	220VAC	115*90*92.7	CE
VC1-0806MDR	8DI/6DO	X	Relay	24VDC	115*90*92.7	CE

Product Model	Digital port (DI/DO)	Removable terminals	Output Type	Power supply	Dimension (unit mm) (L*W*H)	Certification
VC1-0806MDT	8DI/6DO	X	Transistor	24VDC	115*90*92.7	CE
VC1-1208MAR	12DI/8DO	X	Relay	220VAC	115*90*92.7	CE
VC1-1208MAT	12DI/8DO	X	Transistor	220VAC	115*90*92.7	CE
VC1-1208MDR	12DI/8DO	X	Relay	24VDC	115*90*92.7	CE
VC1-1208MDT	12DI/8DO	X	Transistor	24VDC	115*90*92.7	CE
VC1-1410MAR	14DI/10DO	X	Relay	220VAC	115*90*92.7	CE
VC1-1410MAT	14DI/10DO	X	Transistor	220VAC	115*90*92.7	CE
VC1-1410MDR	14DI/10DO	X	Relay	24VDC	115*90*92.7	CE
VC1-1410MDT	14DI/10DO	X	Transistor	24VDC	115*90*92.7	CE
VC1-1614MAR	16DI/14DO	X	Relay	220VAC	115*90*92.7	CE
VC1-1614MAT	16DI/14DO	X	Transistor	220VAC	115*90*92.7	CE
VC1-1614MDR	16DI/14DO	X	Relay	24VDC	115*90*92.7	CE
VC1-1614MDT	16DI/14DO	X	Transistor	24VDC	115*90*92.7	CE
VC1-2820MAR	28DI/20DO	X	Relay	220VAC	192.5*90*92.7	CE
VC1-2820MAT	28DI/20DO	X	Transistor	220VAC	192.5*90*92.7	CE
VC1-2820MDR	28DI/20DO	X	Relay	24VDC	192.5*90*92.7	CE
VC1-2820MDT	28DI/20DO	X	Transistor	24VDC	192.5*90*92.7	CE
VC1-3624MAR	36DI/24DO	X	Relay	220VAC	192.5*90*92.7	CE
VC1-3624MAT	36DI/24DO	X	Transistor	220VAC	192.5*90*92.7	CE
VC1-3624MDR	36DI/24DO	X	Relay	24VDC	192.5*90*92.7	CE
VC1-3624MDT	36DI/24DO	X	Transistor	24VDC	192.5*90*92.7	CE
VC1-0806MAR2	8DI/6DO	Removable	Relay	220VAC	115*90*92.7	CE
VC1-0806MAT2	8DI/6DO	Removable	Transistor	220VAC	115*90*92.7	CE
VC1-1208MAR2	12DI/8DO	Removable	Relay	220VAC	115*90*92.7	CE
VC1-1208MAT2	12DI/8DO	Removable	Transistor	220VAC	115*90*92.7	CE
VC1-1410MAR2	14DI/10DO	Removable	Relay	220VAC	115*90*92.7	CE
VC1-1410MAT2	14DI/10DO	Removable	Transistor	220VAC	115*90*92.7	CE
VC1-1614MAR2	16DI/14DO	Removable	Relay	220VAC	115*90*92.7	CE
VC1-1614MAT2	16DI/14DO	Removable	Transistor	220VAC	115*90*92.7	CE
VC1-2820MAR2	28DI/20DO	Removable	Relay	220VAC	192.5*90*92.7	CE
VC1-2820MAT2	28DI/20DO	Removable	Transistor	220VAC	192.5*90*92.7	CE
VC1-3624MAR2	36DI/24DO	Removable	Relay	220VAC	192.5*90*92.7	CE
VC1-3624MAT2	36DI/24DO	Removable	Transistor	220VAC	192.5*90*92.7	CE
VC1-1616MAR-T	16DI/16DO(2PT)	Removable	Relay	220VAC	192.5*90*92.7	CE

VC3 Series PLC

The VC3 series PLC is a high performance PLC with small structure, powerful functions, and high cost performance, which could be used for multi-channel pulse control applications. It can be widely used in machine manufacturing industries such as CNC machine, textiles, packaging, plastic steel, air conditioners, elevators, printing and so on.

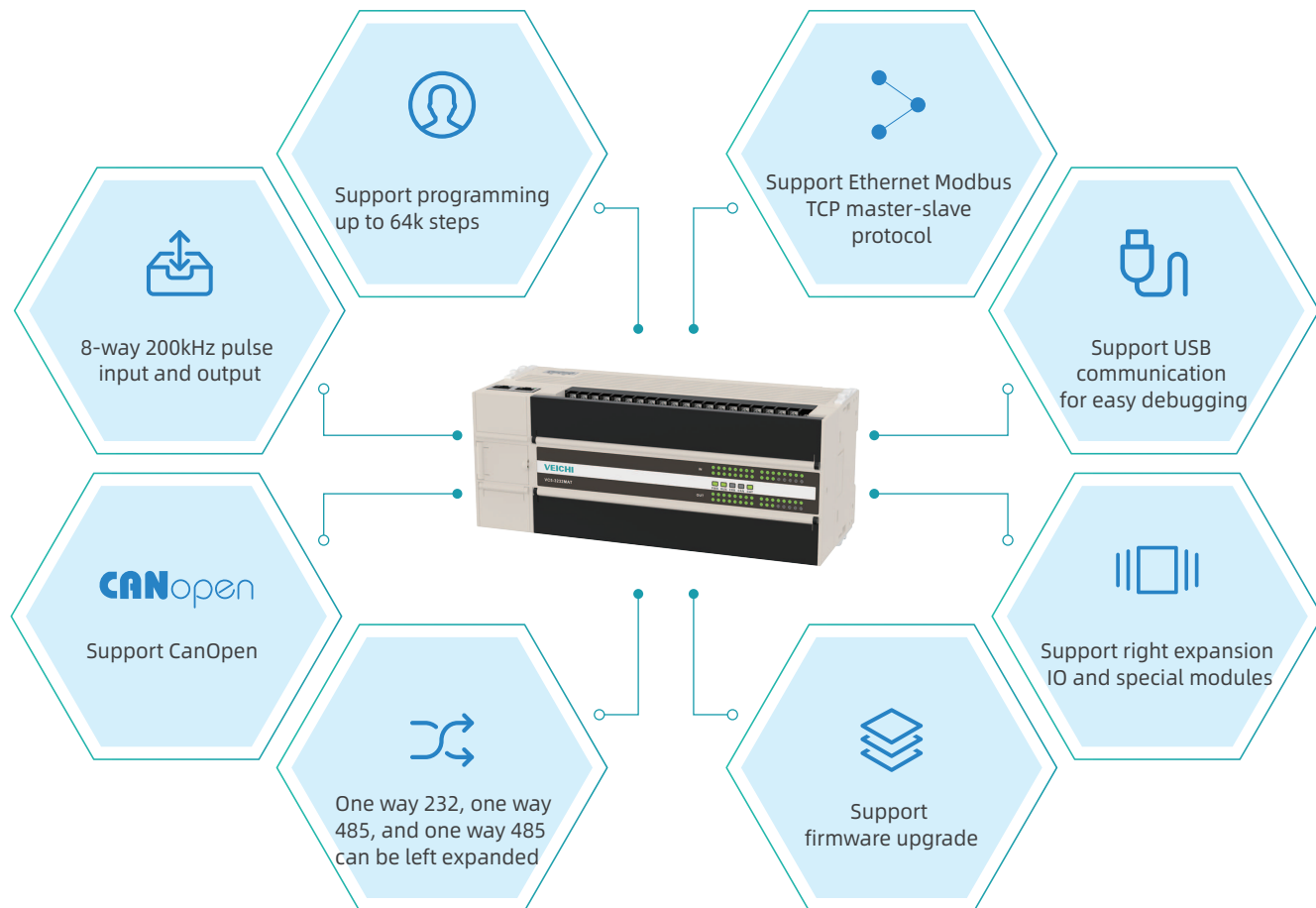

8-channel high-speed pulse output

- Provide 8 high speed pulse outputs.
- Output frequency of 200KHz
- Support positioning control command group, easy for users to realize simple motion control applications
- Function upgrade VC3M, can support linear, circular interpolation, electronic gear, electronic cam motion control

8-channel high-speed counter

- Single-phase supports 8 channels with maximum frequency of 2000KHz, dual-phase supports 4 channels with maximum frequency of 200KHz
- Support single-phase, dual-phase (Up/Down), AB-phase (1X frequency and 4X frequency) counting.

Support Ethernet

- Support Modbus TCP master-slave protocol, can upload/download and monitor the program, can support 16 slave stations and 4 master stations at the same time

Serial communication port

- The body provides one RS232 and one RS485 serial communication port, named COM0 and COM1 respectively, with a maximum communication rate of 115.2K.
- COM0 port can be used as a programming port and also supports Modbus RTU slave protocol.
- COM1 supports Modbus RTU master and slave protocols, free communication, N:N protocol, built-in termination resistor, and dialable code

CAN Interface

- Supports CANOPEN DS402 Master Protocol
- CANOPEN DS301 protocol

USB programming port

- Support USB2.0, compatible with common Type-C USB phone data cable

VC3 series PLC port introduction

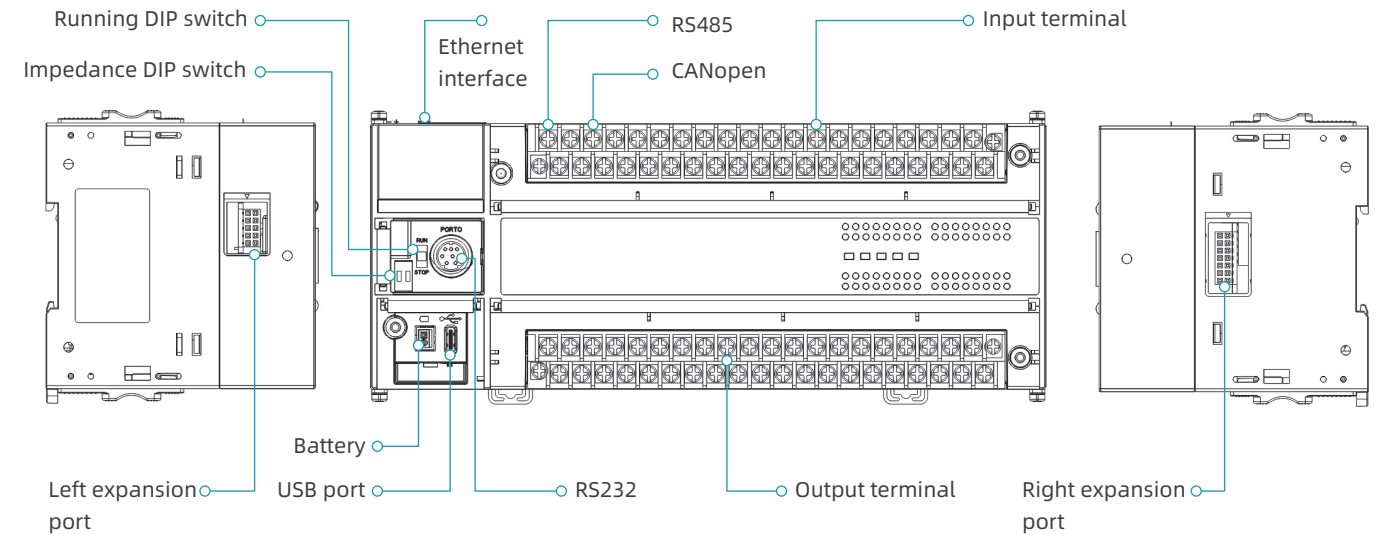

VC3 Series PLC Advantages

VC3M is upgraded on the basis of VC3 platform. With more powerful motion control functions, it could control the multi-axis synchronous motion, and be used for various fields

Linear interpolation, circular interpolation

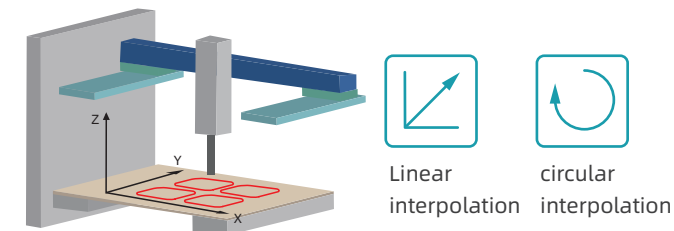

Support 2-axis linear and circular interpolation, corresponding to 2-axis XY platform control, to achieve accurate positioning of the slide.

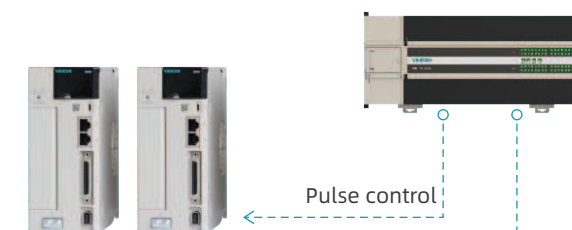

Select the interpolation function to perform linear or circular trajectory operation in XY platform

Electronic gear, electronic cam

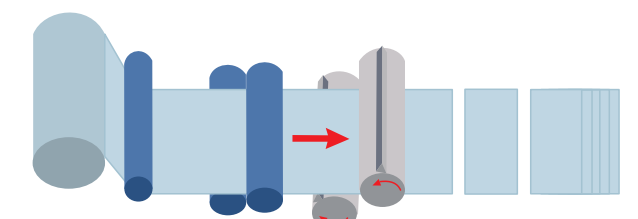

Flying shear function: Track the progress of the material, set the cutting length, automatically plan the operation track, to achieve the material fixed length cutting .

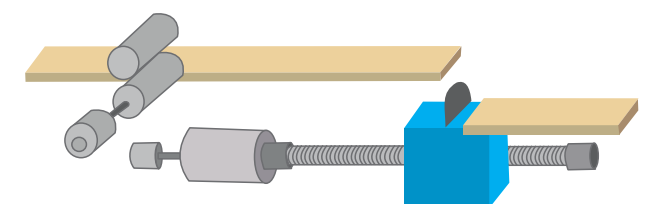

Chasing shear function: Set the starting point and length of the synchronization zone, confirm the allowable travel range of the chasing shear axis and the starting point & end point of the round-trip movement, and plan the cam trajectory curve to achieve synchronized cutting.

VC3 series product specifications

Index		Specifications
Communication function	Ports	2 asynchronous serial communication ports: communication port 0: RS232; communication port 1: RS485; 1 channel Ethernet, 1 channel CAN interface, 1 channel USB interface
	Communications Baud Rate	1.2kbps~115.2kbps
	Communication Protocol	Modbus/FreePort/N:N/CANopen/ModbusTCP/Programming Port Protocol
	USB communication	USB2.0, Type-C interface, support program upload and download, monitoring, firmware upgrade
Digital input and output characteristics	Input Type	Source type, drain type
	Rated voltage	DC24V, 4mA
	Maximum allowable continuous voltage	DC30V
	Logic 1 [Voltage range]	18~30VDC
	Logic 0 [Voltage Range]	0~4VDC
	Input Filter	X0-X7 each channel can be individually set digital filter, input filter constant range (0-60000)*0.25u
	Allowable maximum leakage current	1mA
	Isolation	Photoelectric isolation, 500VAC, 1 min
General Features	High-speed counter	Single-phase 200KHz [8pcs] Dual 200KHz [4pcs]
	Basic instruction execution time	0.065us
	Real-time clock	±45 sec/month (room temperature)
	Max. I/O points	512
	Greater Expansion Module	15 (max. 8 functional modules)
	Power down save soft components	All soft components except R
	Clock	Support
	Program save when power off	Support, save permanently when power off

Digital output characteristics	relay	transistor	
output type	relay	Transistor, NPN output	
		Universal model	Motion Control Model
Rated voltage	24VDC/220VAC	24VDC	
Pulse frequency (maximum)	1Hz	200KHz (8way)	Support 8 channels of 200KHz (transistor output) Support 2-axis linear and circular interpolation Support 4-axis electronic cam

VC3 series selection table

Product Model	Digital port (DI/DO)	Removable terminals	Output type	Power supply	Power supply	Dimensions (unit mm) (L*W*H)	Certification
VC3-1616MAR	16DI/16DO	Removable	Relay	x	220VAC	160*90*92.7	CE
VC3-1616MAT	16DI/16DO	Removable	Transistor	8 way	220VAC	160*90*92.7	CE
VC3-1616MAT-4	16DI/16DO	Removable	Transistor	4 way	220VAC	160*90*92.7	CE
VC3-1616MAT-6	16DI/16DO	Removable	Transistor	6 way	220VAC	160*90*92.7	CE
VC3-3232MAR	32DI/32DO	Removable	Relay	x	220VAC	230*90*92.7	CE
VC3-3232MAT	32DI/32DO	Removable	Transistor	8 way	220VAC	230*90*92.7	CE
VC3-3232MAT-4	32DI/32DO	Removable	Transistor	4 way	220VAC	230*90*92.7	CE
VC3-3232MAT-6	32DI/32DO	Removable	Transistor	6 way	220VAC	230*90*92.7	CE
VC3M-1616MAT	16DI/16DO	Removable	Transistor	8 way	220VAC	160*90*92.7	CE
VC3M-3232MAT	32DI/32DO	Removable	Transistor	8 way	220VAC	230*90*92.7	CE
VC3-1616MDR	16DI/16DO	Removable	Relay	x	24VDC	160*90*92.7	CE
VC3-1616MDT	16DI/16DO	Removable	Transistor	8 way	24VDC	160*90*92.7	CE
VC3-1616MDT-4	16DI/16DO	Removable	Transistor	4 way	24VDC	160*90*92.7	CE
VC3-1616MDT-6	16DI/16DO	Removable	Transistor	6 way	24VDC	160*90*92.7	CE
VC3-3232MDR	32DI/32DO	Removable	Relay	x	24VDC	230*90*92.7	CE
VC3-3232MDT	32DI/32DO	Removable	Transistor	8 way	24VDC	230*90*92.7	CE
VC3-3232MDT-4	32DI/32DO	Removable	Transistor	4 way	24VDC	230*90*92.7	CE
VC3-3232MDT-6	32DI/32DO	Removable	Transistor	6 way	24VDC	230*90*92.7	CE
VC3M-1616MDT	16DI/16DO	Removable	Transistor	8 way	24VDC	160*90*92.7	CE
VC3M-3232MDT	32DI/32DO	Removable	Transistor	8 way	24VDC	230*90*92.7	CE

VC5 series PLC

The VC5 series is a high-performance small PLC with EtherCAT bus, including 32/64-point specifications, which makes the line equipment run rapidly and relieves the huge pressure on production. VC5 can simplify the wiring, speed up the programming and debugging time, meet the requirements of the shaft capacity and the strict cost control requirements, and realize the multi-axis servo control.

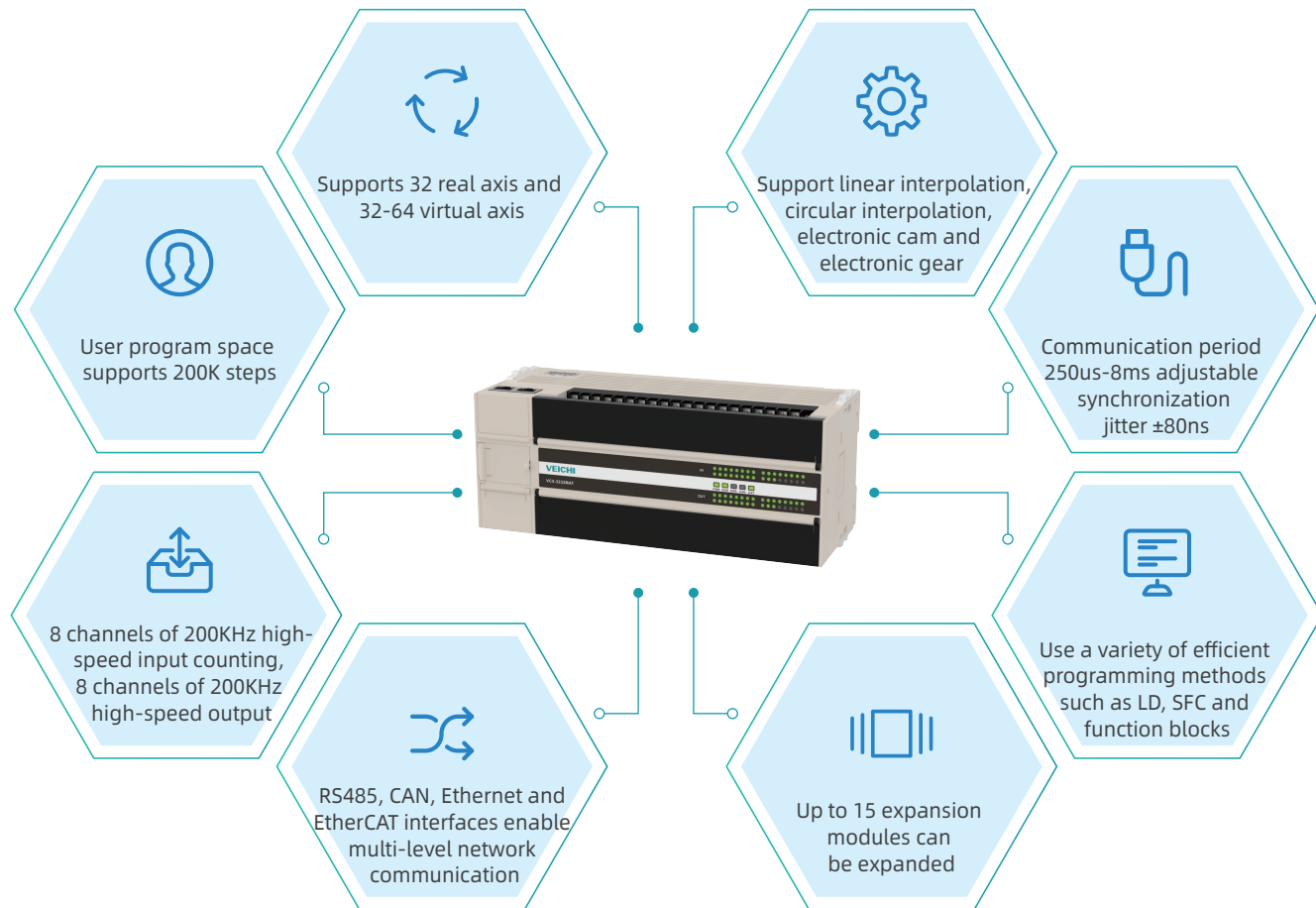

EtherCAT bus

- A maximum of 32 real axis EtherCAT bus motion control, a total of 64 real axis virtual axis, including: bus servo axis, bus encoder axis, local pulse axis, local encoder axis;
- Support absolute/relative, speed, torque, jog control, interpolation functions;
- Supports up to 72 EtherCAT slaves ;

sport control

- Based on PLCopen motion control instructions, it can achieve a maximum of 32 cycles of motion control;
- The host supports 4-axis 200KHz pulse output, 8-channel 200KHz high-speed input;

Rich programming

- Use LD/SFC programming, function block instructions and other efficient;
- Efficient programming methods; Use the oscilloscope function of the host computer to make debugging more editable;

High-speed input and output

- The host body comes with 32 channels of input and 32 channels of output, including 8 channels of high-speed input and 8 channels of high-speed output, which can realize 4-axis pulse output and 4-axis encoder counting;
- Up to 15 expansion modules can be expanded;

Electronic cam, electronic gear

- Support linear interpolation, circular interpolation, support electronic cam and electronic gear functions;

VC5 series PLC product advantages

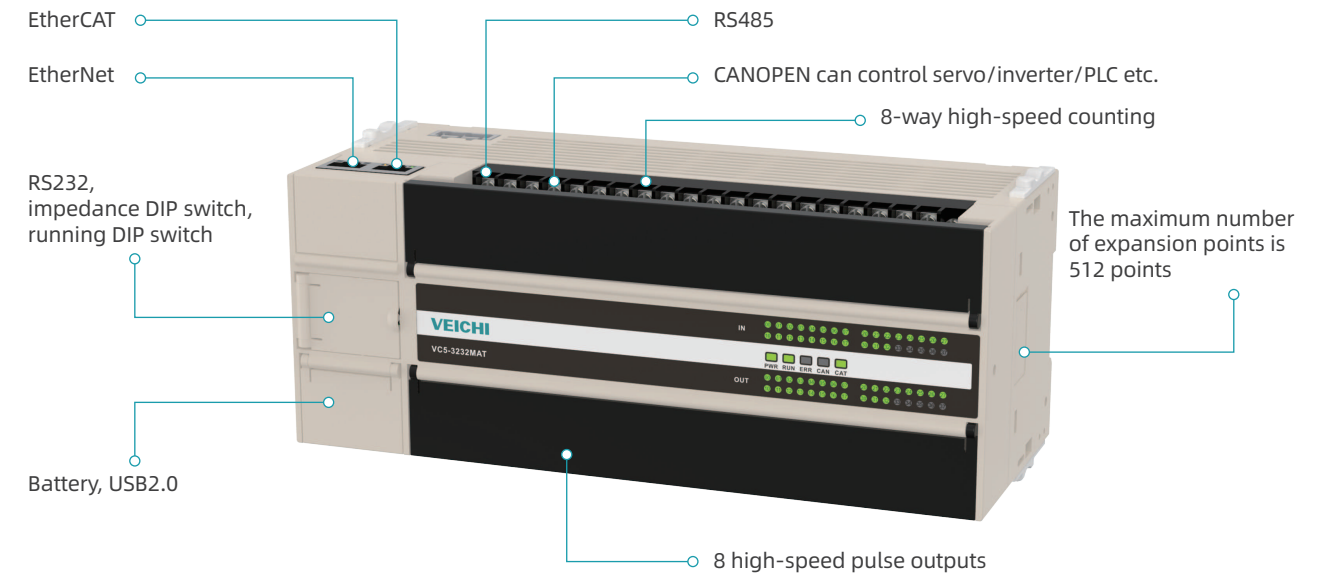

- Motion network bus EtherCAT, the fastest communication cycle is 250us
- Support multi-axis commands such as electronic gear and electronic cam
- Support single-axis motion commands such as position, speed, and homing
- The spindle can choose encoder or virtual axis, real axis. external input etc.
- Supports Servo Probe, High Speed Probe, Encoder Probe
- Supports phase compensation, motion superposition, etc.

Generalization of EtherCAT

VC5 fulfills the requirement of "implementing multi-axis positioning control with small equipment" in a true sense.

No complicated wiring is required, saving design man-hours and wiring man-hours, and easy maintenance.

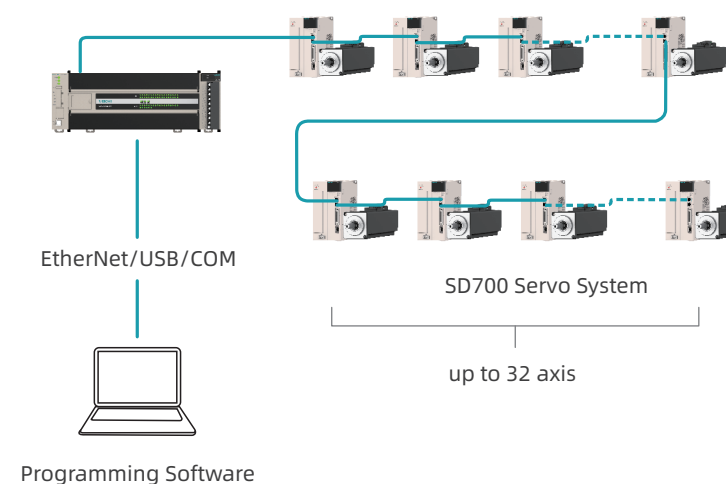

Instructions support Jerk acceleration and deceleration methods

When smooth acceleration and deceleration are required, the Jerk value can be adjusted to smooth the curve and reduce mechanical impact.

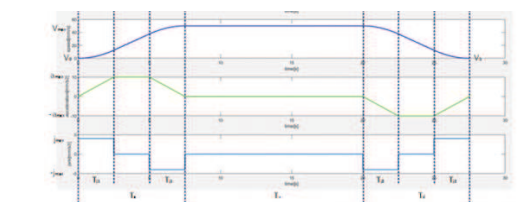

(The abscissa is time, the ordinate of the first graph is velocity, the ordinate of the second graph is acceleration, and the ordinate of the third graph is the rate of change of acceleration)

- No need to calculate, directly obtain the corresponding acceleration and deceleration rate of change through the acceleration and deceleration time
- It directly reflects the change of the smoothness of the acceleration and deceleration curve

VC5 series technical parameters

Index		Specification
Communication function	Port	2 asynchronous serial communication ports: communication port 0: RS232; communication port 1: RS485; 1 Ethernet, 1 CAN interface, 1 EtherCAT, 1 USB interface
	Communication baud rate	1.2kbps~115.2kbps
	Protocol	Modbus/Freeport/N:N/CANopen/ModbusTCP/Programming port protocol
	USB communication	USB2.0, Typc interface, support program upload and download, monitoring, firmware upgrade
Digital input and output characteristics	Input type	Source, drain type
	Rated voltage	DC24V, 4mA
	Logic 1 [Voltage Range]	18~30VDC
	Logic 0 [Voltage Range]	0~4VDC
	Input filter	Digital filter can be set independently for each channel of X0-X7, input filter constant range (0-60000)*0.25us
	Allowable leakage current [Maximum]	1mA
	Isolation	Photoelectric isolation, 500VAC, 1 minute
	High-speed counter	Single-phase 200KHz [8 pieces] Dual-phase 200KHZ [4 pieces]
	High-speed pulse output	8 channels 200KHz
	General Features	Basic instruction execution time
Real Time Clock		±45 seconds/month (normal temperature)
Maximum I/O Points		512
Maximum expansion module		15 (maximum 8 functional modules)
Power down save soft components		All soft components except W
Clock		Support
Program power-down hold		Support, power down permanent storage
EtherCAT	Communication cycle	Adjustable from 250us-8ms
	Number of control axis	Up to actual axis: 32 axis, imaginary axis 32-64
	Position Control	PTP control, absolute positioning, relative positioning, Jerk acceleration and deceleration
	Operation Control Mode	Straight line, circular arc, cam
	Return to home mode	Pulse support 11 kinds/bus support servo all kinds
	Synchronous jitter	±80ns

VC5 series selection table

Product Model	Digital port (DI/DO)	Removable terminals	Output type	Bus axis	Power supply	Dimensions (unit mm) (L*W*H)	Certification
VC5-3232MAT-8	32DI/32DO	Removable	Transistor	8	220VAC	230*90*92.7	CE
VC5-3232MAT-16	32DI/32DO	Removable	Transistor	16	220VAC	230*90*92.7	CE
VC5-3232MAT-32	32DI/32DO	Removable	Transistor	32	220VAC	230*90*92.7	CE
VC5-1616MAT-8	16DI/16DO	Removable	Transistor	8	220VAC	160*90*92.7	CE
VC5-1616MAT-16	16DI/16DO	Removable	Transistor	16	220VAC	160*90*92.7	CE
VC5-1616MAT-32	16DI/16DO	Removable	Transistor	32	220VAC	160*90*92.7	CE
VC5-1616MAT-48	16DI/16DO	Removable	Transistor	48	220VAC	160*90*92.7	CE

Expansion Modules and Options



IO Expansion Module	Instruction	Certification
VC-0808ENR	8 points DC24V input, 8 points relay output	CE
VC-0808ENT	8 points DC24V input, 8 points transistor output	CE
VC-1600ENN	16 points DC24V input	CE
VC-0016ENR	16-point relay output	CE
VC-0016ENT	16-point transistor output	CE

Left Expansion Module	Instruction	Certification
VC-RS485	RS485 left Expansion Module	CE
VC-ENet	Ethernet Left Expansion Module	CE

Special Modules	Instruction	Certification
VC-4AD	4-channel analog input module	CE
VC-4DA	4-channel analog output module	CE
VC-4TC	4-way thermocouple temperature module	CE
VC-4PT	4-way RTD temperature module	CE
VC-24V5POW	24V extension power module	CE

Optional Accessories	Instruction	Wire length
VC-SL1	DB9 to DIN8 touch screen PLC serial connection cable	3m
VC-SL2	USB A head to DIN8 serial communication cable	3m
VC-SL3	USB communication cable	3m

Installation size of left and right expansion modules with different points of main module

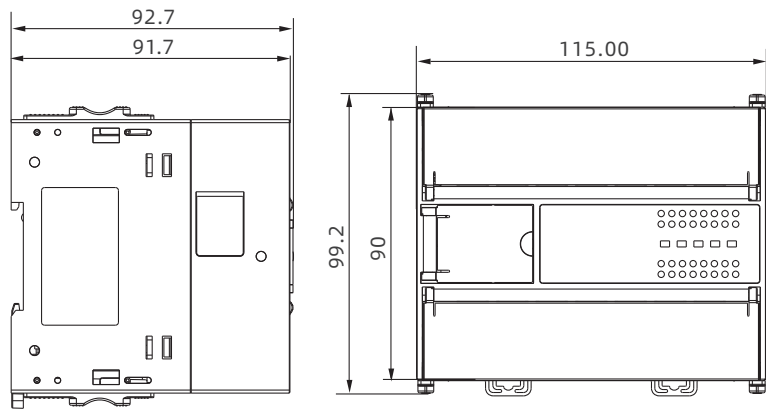

Dimensional drawing of VC1 main module

Applicable models

VC1-0806MAR
VC1-0806MAT
VC1-1208MAR
VC1-1208MAT
VC1-1410MAR
VC1-1410MAT
VC1-1614MAR
VC1-1614MAT
VC1-0806MAR2
VC1-0806MAT2
VC1-1208MAR2
VC1-1208MAT2
VC1-1410MAR2
VC1-1410MAT2
VC1-1614MAR2
VC1-1614MAT2

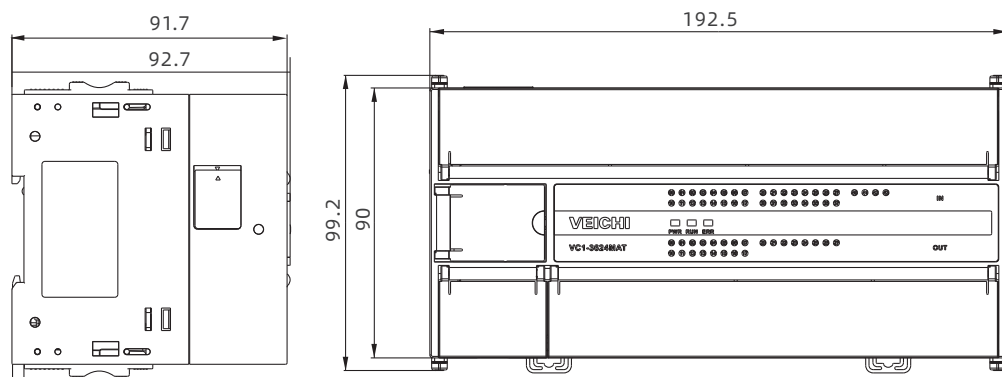

VC1 main module long point size diagram

Applicable models

VC1-2820MAR
VC1-2820MAT
VC1-3624MAR
VC1-3624MAT
VC1-2820MAR2
VC1-2820MAT2
VC1-3624MAR2
VC1-3624MAT2

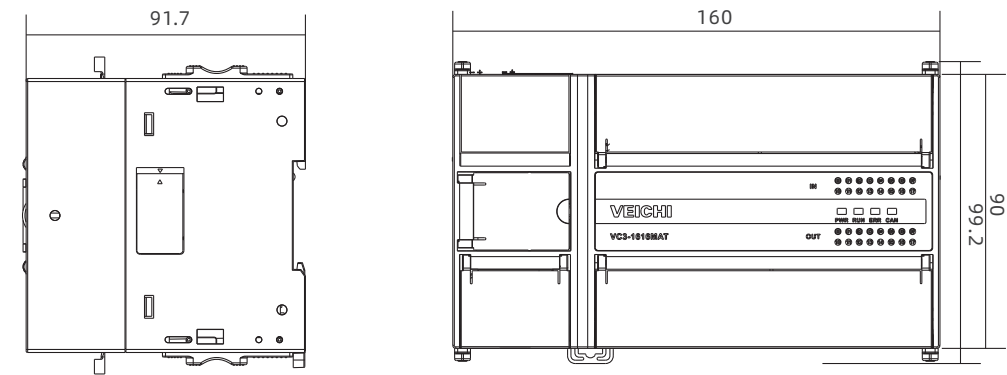

VC3/VC5 main module dimensional drawing

Applicable models

VC3-1616MAT
VC3-1616MAR
VC3-1616MAT-4
VC3-1616MAT-6
VC3M-1616MAT
VC5-1616MAT

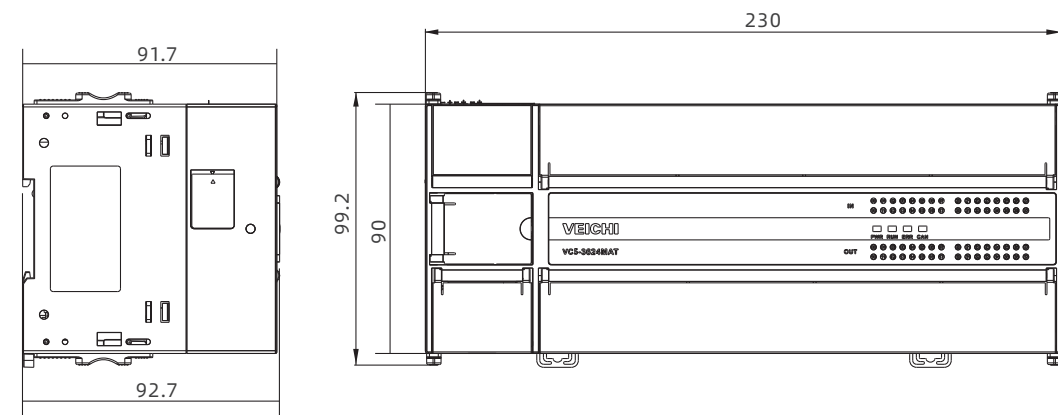

VC3/VC5 long point master module size diagram

Applicable models

VC3-3232MAT
VC3-3232MAR
VC3-3232MAT-4
VC3-3232MAT-6
VC3M-3232MAT
VC5-3232MAT

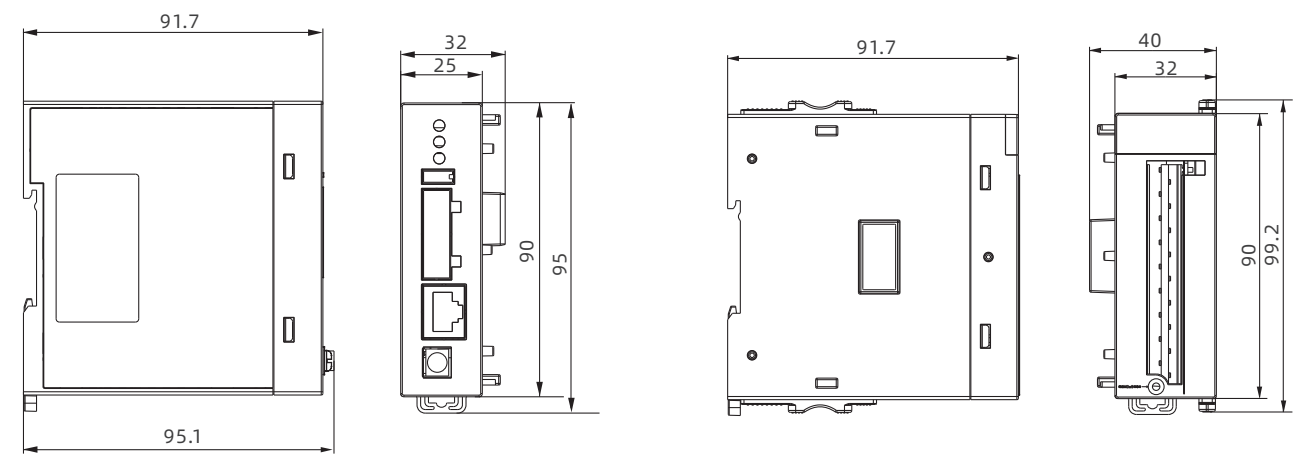

Left expansion module size chart

Right expansion module size chart

programming software

Quickly set complex instruction addresses, inputs and outputs, and other parameters. Automatically generate execution subroutines to ensure accurate and precise programs; add function blocks and oscilloscope functions to make debugging more convenient

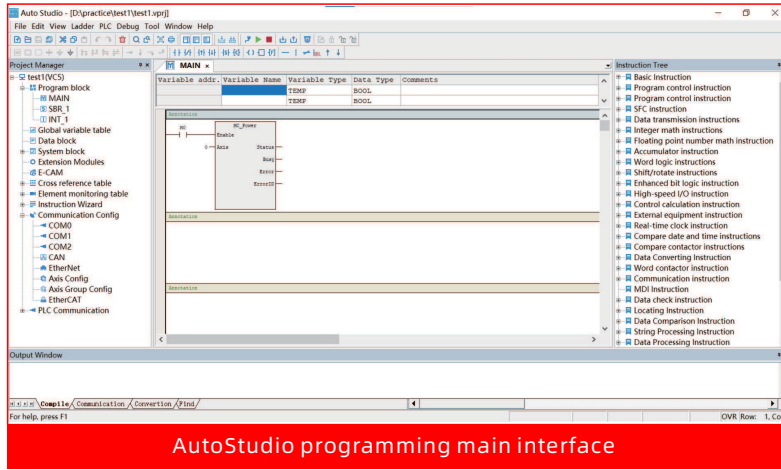

AutoStudio programming main interface

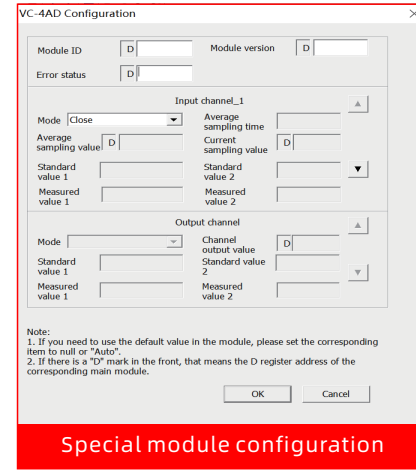

Special module configuration

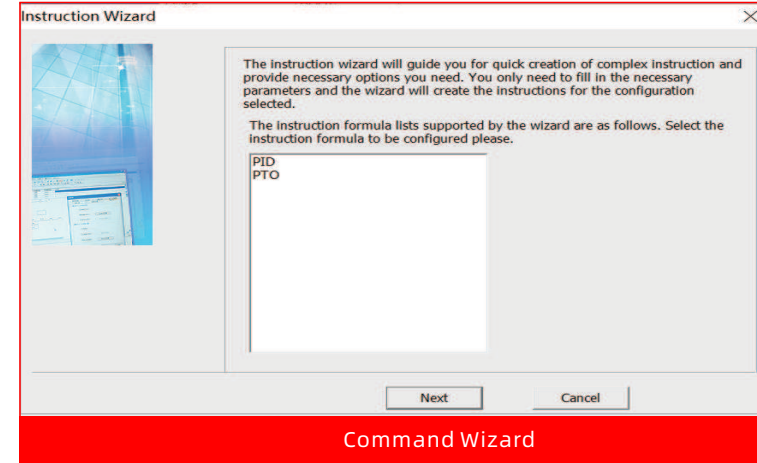

Command Wizard

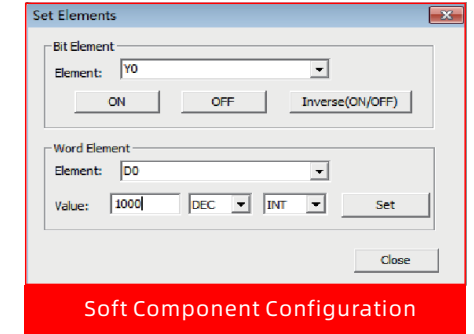

Soft Component Configuration

Support multiple programming languages and their mutual conversion

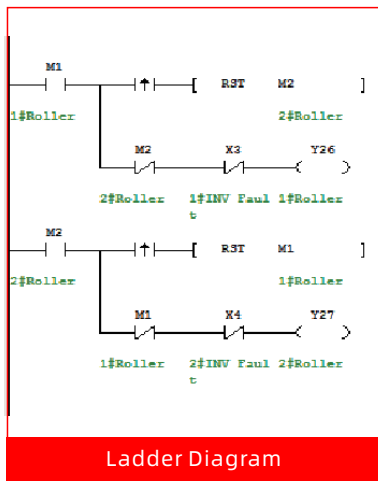

Ladder Diagram

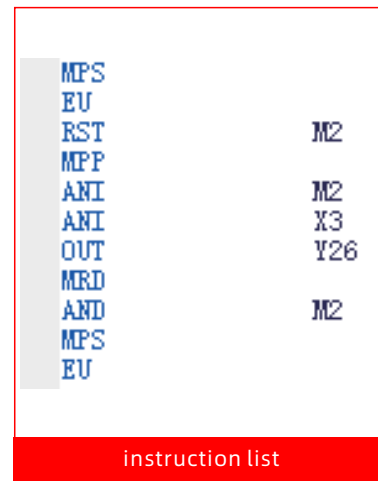

instruction list

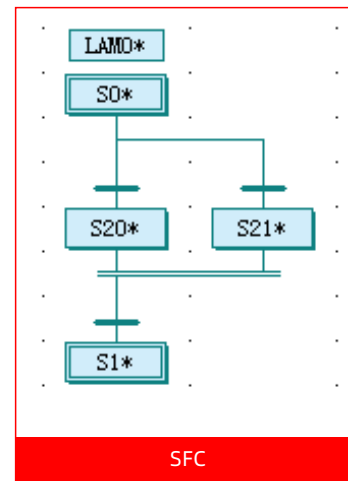

SFC

Num	Slave ID	Com Type/Func	Trigger Elem	Slave Reg	Length	Master Elem	Remark
0	1	trigger read resistor (03)	MC000	7000	1	D0000	
1	1	trigger read resistor (03)	MC001	2000	1	D0100	
2	1	loop read resistor (03)		2000	1	D0200	
3	1	loop read resistor (03)		2000	1	D0300	

ModBus Command Form

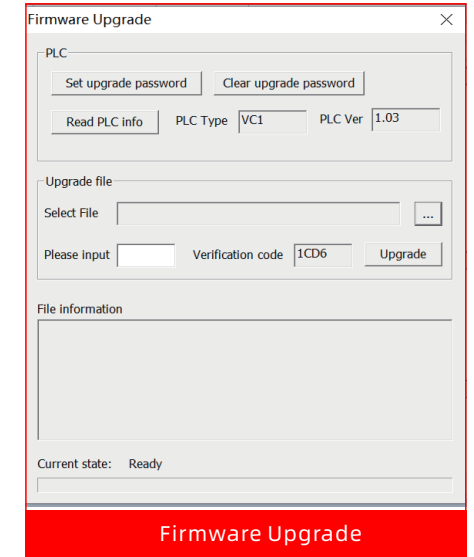

Firmware Upgrade

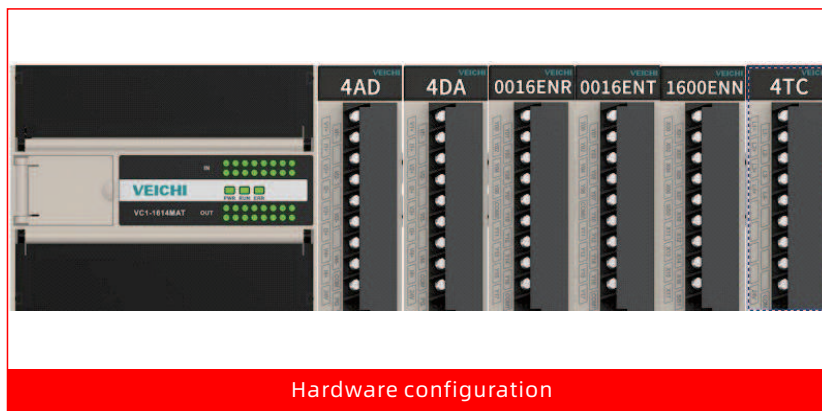

Hardware configuration

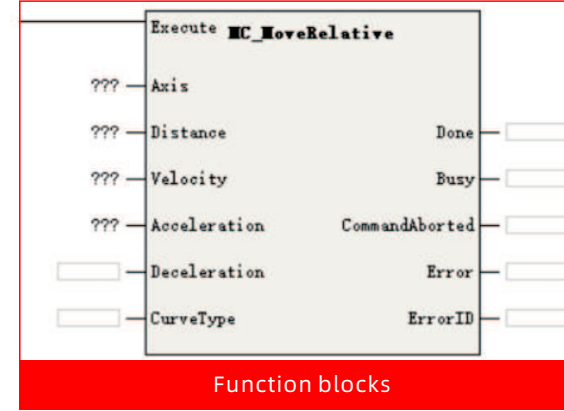

Function blocks

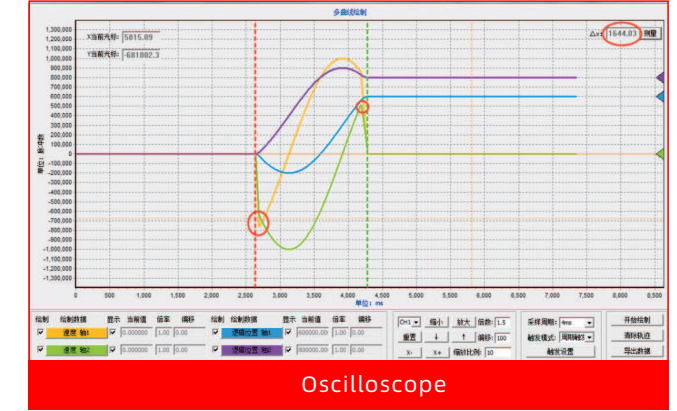

Oscilloscope