

VEICHI



MANUAL

**AC70S Construction Hoist
Specialized Inverter**

CONTENT

Chapter 1 Overview	1
1.1 Safety requirement and cautions	1
1.2 Technical Specification.....	3
1.3 Product Features	5
Chapter 2 Before Use	6
2.1 Purchase inspection.....	6
2.2 Nameplate	6
2.3 Model and rated output current	7
2.4 Dimension	7
2.5 Electrical installation	8
2.6 Standard connecting diagram	9
2.7 Main circuit terminal	10
Chapter 3 Keyboard and Operation	11
3.1 Keyboard appearance and function	11
3.2 Indicator light meanings	12
Chapter 4 Function Parameter Table	13
4.1 Basic parameter	13
4.2 Special Function Description	20
4.3 Monitor code	21
Chapter 5 Fault Information	23
5.1 Fault Information	23
Chapter 6 Debugging Instructions	26
6.1 Debugging Steps	26
6.2 Debugging Precautions	27
6.3 Problems & Solutions in the Debugging Process	27

Chapter 1 Overview



Thanks for using construction hoist specialized frequency inverter produced by Veichi electric Co., Ltd. This manual tells you how to use it perfectly. Please read this manual carefully and fully understand the safety requirement and cautions before use (installation, wiring, operation, maintain, checking, and etc...).

1.1 Safety requirement and cautions

Pls do fully understand this part before using the inverter.

Warning signs and meanings

This manual has used below signs that mean it is an important security content. While operating against the rules, there is danger of injury even death or machine system damage.

 Danger	<p>Danger: Wrong operation may cause death or large accident.</p>
 Warn	<p>Warning: Wrong operation may cause death or large accident.</p>
 Caution	<p>Caution: Wrong operation may cause minor wound.</p>
Important	<p>Important: Wrong operation may cause the inverter and other related machine system damage.</p>

Operation requirement



Only Professional trained person are allowed to operate the equipment such as installation, wiring, running, maintain and etc. "Professional trained person" in this manual means the workers on this product must experience professional skill train, must be familiar with installation, wiring, running and maintain and can rightly deal with emergency cases in use.

Safety guidance



Safety regulations and warning signs come for your security. They are measures to prevent the operator and machine system from damage. Please carefully read this manual before using and strictly observe the regulations and warning signs while operating. Safety regulations and warning signs are classified into: routine regulation, transport and store regulation, installation and wiring regulation, running regulation, maintenance regulation, dismantlement and disposal regulation.

● Routine regulation

 Warn	<ul style="list-style-type: none"> ● This product carries dangerous voltage and controls driver (motion) machine with potential danger. If you don't abide by the regulations or requirements in this manual, there is danger of body injury even death and machine system damage. ● Only qualified personnel are allowed to operate the equipment. Before using this product, the operator must be familiar with all safety specifications and operation regulations in this manual. Safe and stable work of the product is based on right operation and maintenance. ● Do not wire while the power is connected. Otherwise, there is danger of death for electric shock. Before wiring, inspection, maintenance, please cut power supply of all related equipment and ensure mains DC voltage falling to safe range. And please operate it after 5 mins.
--	---

 Caution	<ul style="list-style-type: none"> ● Away from children and public. ● Only used in application fields as maker stated. Without permission not used in special fields such as emergency, succor, ship, medical treatment, aviation, nuclear and. Etc.) ● Unauthorized alteration or use of accessories which are not sold or recommended by the maker may cause faults.
 Important	<ul style="list-style-type: none"> ● Please make sure this manual is in the final user's hand before using, and make sure that the final user can read this manual carefully before using. ● Before installation and debugging please carefully read and totally understand these safety regulation and warning signs.

● Transport and store regulation

 Warn	<ul style="list-style-type: none"> ● Correct transport, store, installation and careful operation and maintenance are important for inverter safe operation.
 Caution	<ul style="list-style-type: none"> ● In transport and store process, make sure the inverter is free from impact and vibration. It must be stored in a dry, no corrosive air, no conductive dust) and the temperature must be lower than 60°C.

● Installation and wiring regulation

 Warn	<ul style="list-style-type: none"> ● Only professional trained person can operate it. ● Power wire, motor wire and control wire should be all connected firmly. Earth terminal must be reliable and earth resistance must be lower than 10Ω. ● Before opening the pane), please cut all related equipment power supply and make sure the mains DC voltage is falling to safe range and operate after 5mins. ● Human body electrostatic will inverter inner sensitive components seriously. Before operation, please follow ESD measures. Otherwise, there is danger of inverter damage. ● Inverter output voltage is pulse wave. If components such as capacitor which improves power factor and pressure-sensitive resistance for anti-thunder and so on are installed at the output side, please dismantle them or change to input side. ● Not install switch components such as breaker and contactor at the output side. (If there must be (installed, please make sure the output current is 0 while the switch acting).
--	---

● Run regulation

 Warn	<ul style="list-style-type: none"> ● Inverter runs at high voltage. So dangerous voltage is inevitably in some components. ● No matter where the fault is, there is a danger of serious accident, even human body injury, and that means exist potential dangerous malfunction possibility). So there must be additional external prevent measures or other safety devices, such as independent current limiting switch, machinery fense and so on. ● In order to guarantee the right action of the motor's overload protection, the parameters of motor input to the inverter must be in full compliance with the actual used motor.
--	--

● Maintenance regulation

 Warn	<ul style="list-style-type: none"> ● Only Shenzhen Veichi Electric co., ltd service department or its authorized service center or professional person trained and authorized by Veichi can maintain the products. They should be very familiar with the safety warning and operation gist in this manual. ● Any defective components must be changed in time.
--	--

- Before opening the inverter to repair please cut power supply of all related equipment and ensure mains DC voltage in safe range. And please do operation after 5 mins.

• Dismantlement and disposal regulation



- Packing case can be reused. Please keep them and reuse or send back to maker.
- Dismantled metal components are retractable and can be reused.
- Some components such as electrolytic capacitor are harmful to environment. Please dispose according to environmental protection departments.

1.2 Technical Specification

Items		Description
Power Input	Voltage, frequency	Three phase 380V 50/60Hz
	Allowable fluctuations	Voltage: 320V-440V; voltage unbalance rate: <3%; Frequency: $\pm 5\%$; distortion rate: confirm to IEC61800-2.
	Power factor	≥ 0.94 (with DC reactor)
	Efficiency	$\geq 96\%$
Output	Output voltage	3 phase, 0-input voltage, tolerance less than 5%, in standard rating condition
	Output frequency range	0-320Hz
	Output frequency accuracy	$\pm 0.5\%$ of maximum frequency
	Overload tolerance	150% rated current: 1min, 180% rated current: 10s, 200% rated current: 0.5s
Key Control Performance	Carrier frequency	0.6-15.0kHz
	Steady speed control accuracy	VC without PG: $\leq 1\%$ rated synchronized speed
	Starting torque	Flux VC without PG: 180% rated torque at 0.5Hz
	Frequency accuracy	Digital input: maximum $\times \pm 0.01\%$ Analog input: maximum $\times \pm 0.2\%$
	Frequency resolution	Digital input: 0.01Hz Analog input: maximum $\times 0.05\%$
Basic Functions	DC braking	Starting frequency: 0.00-60.00Hz Braking time: 0.0-60.0s Braking current: 0.0-150.0% rated current
	Accelerate / Decelerate curve	Two modes: line ACC./DEC, S curve ACC./DEC.; Four sets ACC./DEC., time unit: 0.01s, maximum: 650.00s.
	AVR (Auto Voltage Regulation)	Auto voltage regulation for keeping output voltage stable when grid voltage fluctuation.
	Auto current limit	Auto current limit during running mode to avoid trip occurs frequently.

	Momentary power loss with no stop running function	Achieve continuous running through bus voltage control, when momentary power loss.	
	Frequency setting channels	Keypad digital setting, potentiometer of keypad, analog voltage terminal VS1, analog voltage terminal VS2, analog current terminal AS, communication given and multiple terminal, main and auxiliary composition setting.	
	Feedback input channel	Voltage terminal VS1, VS2, current terminal AS, communication given and pulse input PUL.	
	Running command channel	Keyboard given, external terminal given, communication given.	
	Input command signal	Start, stop, FWD/REV, JOG, multiple speed, free stop, reset, ACC/DEC time selection, frequency setting channel selection, external fault alarm.	
	External output signal	1 relay output, 2 collector output, 0-10V output, 4-20mA output, frequency pulse output.	
Protection function		Overvoltage, undervoltage, current limit, overcurrent, overload, electric thermal relay, overheat, overvoltage stall, data protection.	
Keyboard display	LED display	Double line 4 digital tube display	Can monitor the status of 2 VFD.
	Parameter copy	Upload & download parameter code of inverter to achieve easy & fast parameter copy.	
	Monitor function	Output frequency, given frequency, output current, input voltage, output voltage, motor speed, PID feedback value, PID given value, module temperature, input/output terminal status.	
	Alarm	Overvoltage, undervoltage, overcurrent, short circuit, phase loss, overload, overheat, overvoltage stall, current limit, data protect damage; Fault running state at present; Fault history.	
Environment	Installation site	Indoor, altitude $\leq 1000\text{m}$, no corrosive gases and direct sunshine	
	Temperature, humidity	-10 ~ +40 °C (wall-mounted type) 20%~90%RH (no condensation)	
	Vibration	$\leq 0.5\text{g}$ under 20Hz	
	Store temperature	-25~+65 °C	
	Installation type	Wall-mounted type	
	Protection degree	IP54	
	Cooling method	Forced air-cooling	

1.3 Product Features

- The installation is simple. Without changing the original power frequency box case, only needed to install the drive and resistance box, the whole transformation work will be completed.
- Do not need to replace the console. Using the original console can also achieve smooth switch between low speed and high speed, and enhance work efficiency.
- Do not need to add the deceleration limit switch and speed bump iron. It can guarantee precise leveling at any speed without impacting the bottom.
- Cost-effective. Compared to complete sets of cabinet with frequency inverter, the integrated control system is cheap with comparative performance.
- It can display a variety of limit status, up and down signal, and it is easy in maintenance and repair.
- The mounting bar can be of any combination to achieve flexible installation such as up-and-down installation, left-and-right installation.
- The thickness of machine body is only 205mm, suitable for in-cage installation (usually the thickness of frequency inverter is 260mm).
- Specially designed with IP54 protection grade for the construction hoisting site.
- According to the mechanical characteristics of construction lift in use, the product has tested by the vibration test rig for seismic test.
- Dedicated logic brake sequencing control ensures safety and reliability.
- Stable performance, safe and reliable. With zero speed torque maintaining function, It does not rely on the support of brake action during forward and reverse zero-speed.
- Built-in braking unit with resistance short-circuit protection.
- During frequent jog operation, it has zero dead zone compensation without vibration and downside phenomenon, suitable for worm gear reducer, gear machine and other integrated construction machine of any drive mechanism.
- No need to set parameters, users can connect the motor and control wire correctly. It can work normally after start.

Chapter 2 Before Use

2.1 Purchase inspection

When you receive the product, please check if there is any damage on the outer packing before you open it. If the package is ok, please open it and check the inverter. Note: any damage caused in transport will not be duty of our company, but please contact us and the transport company immediately.

After checking the product, please also check if the model is the one you ordered. The model of the product is on the nameplate "MODEL" column. If the model is not in accordance with your need, please contact the agent or the sales department in our company.

2.2 Nameplate

Nameplate position and content

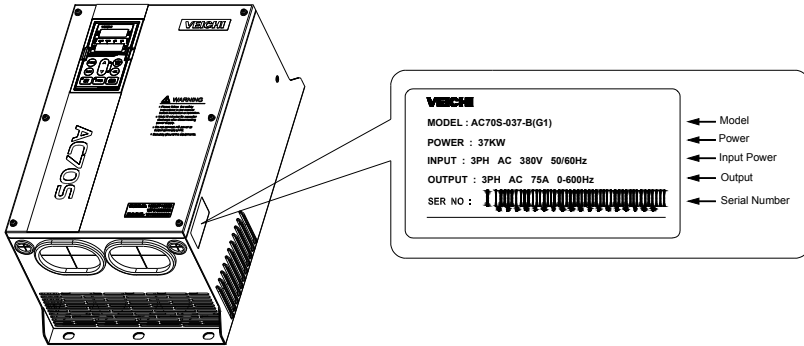

Model explanation

AC70S - 037 - B(G1)

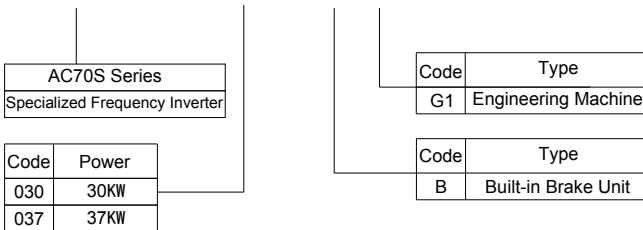

2.3 Model and rated output current

Model	Adaptive motor power	Rated input voltage	Rated current	Motor configuration
AC70S-O30-B(G1)	30KW	3PH 380VAC	60A	11KW*2 13KW*2
AC70S-O37-B(G1)	37KW		75A	11KW*3 15KW*2

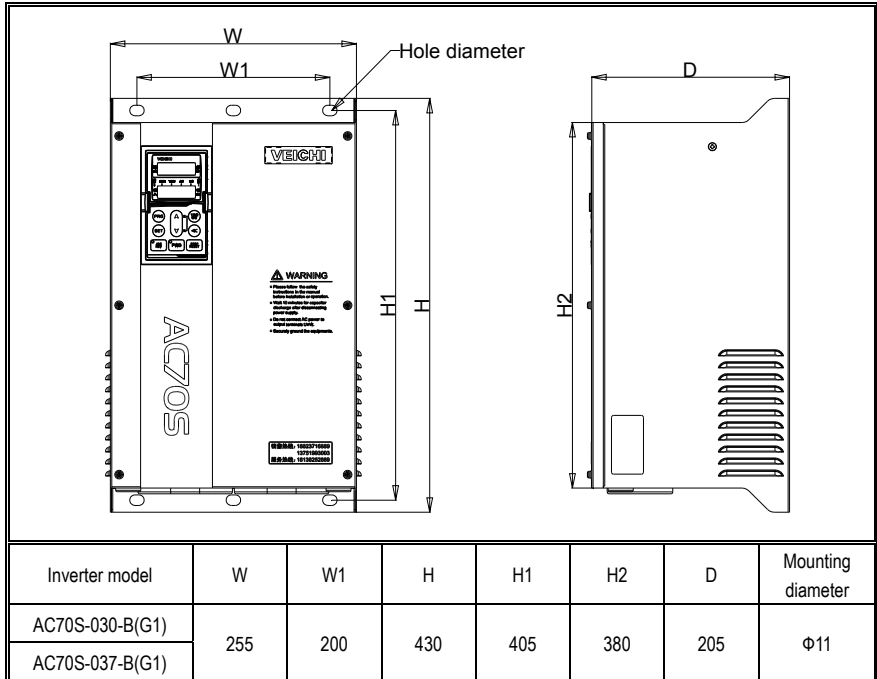

2.4 Dimension



2.5 Electrical installation

This section is to ensure the safe use of this product, maximize give play to the performance of inverter, the reliable running of inverter, the users must comply with the below considerations and requirements.

Safety Precautions

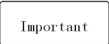
	<ul style="list-style-type: none"> ● In the operation, inverter must be reliable ground connection, otherwise it may cause personal injury and equipment working failed. ● To insure the safety running of inverter, installation and wiring must be done by professional electrical engineering personnel only. ● Do the relevant operation only under the state of power off, otherwise there is the risk of electric shock and death. ● Before doing the relevant operation, please power-off all the related equipment, and confirm that the major loop DC voltage has fallen to safe level. After that, please wait for 5mins and then continue the relevant operation.
	<ul style="list-style-type: none"> ● The inverter's control cable, power cable and the connecting cable of the motor must be isolated to each other, do not put them all in the same cable slot or on the cable rack. ● This equipment can only be used in the application which prescribed by the manufacturer. If you need to use it in other special occasion, please consult the sales department of our company.
	<ul style="list-style-type: none"> ● Testing the insulation of inverter and its connecting wires by the high voltage insulation test equipment is forbidden. ● When doing the insulation test to the inverter and its peripherals (filter, reactor, etc.), please first use the 500V megohmmeter to measure its insulation resistance to earth, the insulation resistance is not less than 4M Ω .

Special considerations for field installation and debugging:

1. When the motor drive board and hoisting cage release (pin roll not connected), use the handle to increase/decrease inching operation, at this time, if the driving board kept moving upward direction, this is normal phenomenon, it means the electrical connection is in the right direction. If the driving board kept moving downward direction, it means the motor connection is in the opposite direction, needs to change the motor cable.
2. When the GPS remote control is locked, the inverter will show "E.EF" or "LIFE" default, cannot be reset. It is only allowed to run downward, not allowed to run upward.

2.6 Standard connecting diagram

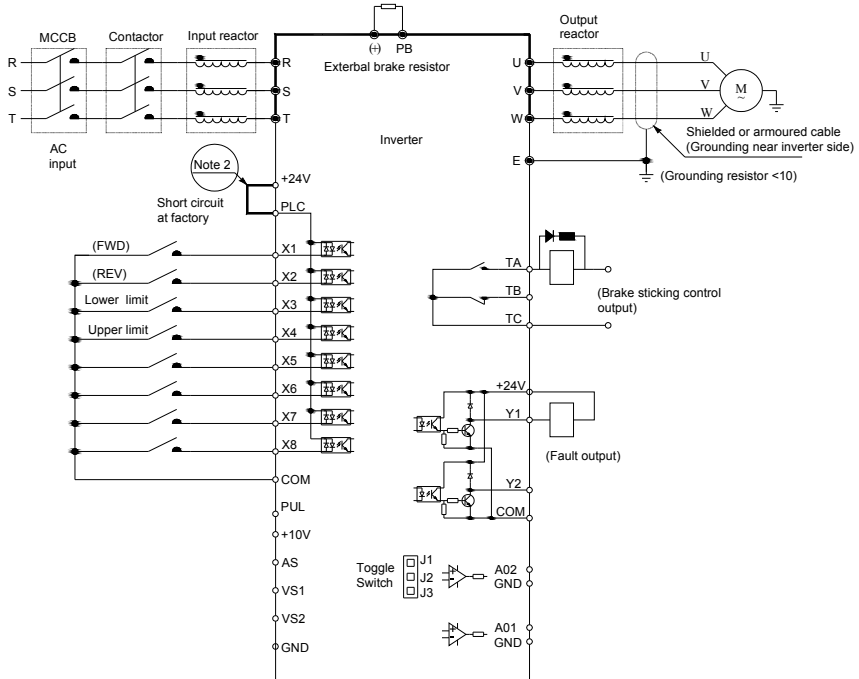

Precautions:

1. Multi-functional input terminal (X1~X8) can choose NPN or PNP transistor signal as the input, the bias voltage can choose the inverter internal power supply (+24V terminal) or external power supply (PLC terminal), factory value "+24V" and "PLC" are short connected.
2. Analog monitoring output is for the specialized output of frequency meter, ammeter, voltmeter, etc. Cannot be used for the control operations, like feedback control.
3. Due to the variety of pulse type in the actual use, the specific connecting mode please refers to the detailed description.

2.7 Main circuit terminal

- The permutation and definition of main circuit terminal

The display order of Power main circuit terminal:

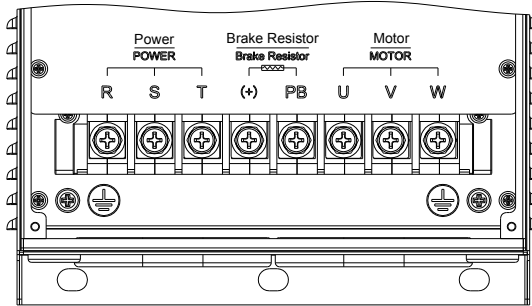







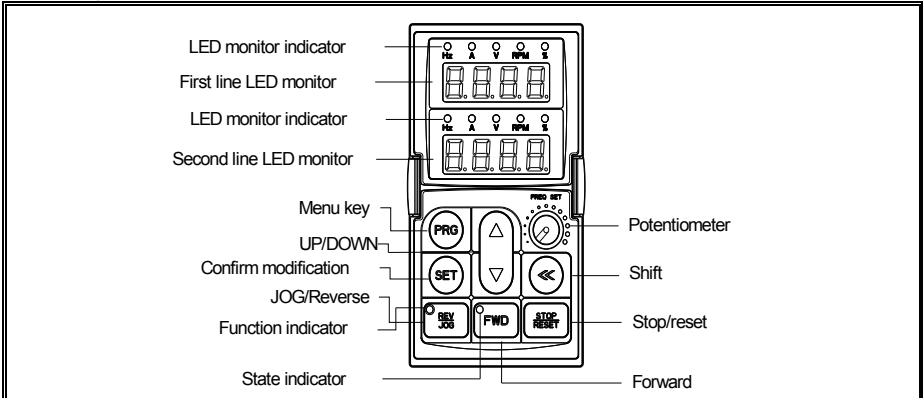

Terminal Symbol	Terminal Name	Terminal Function Definition
(+)	Braking resistor terminal	Used for external braking resistor, achieve to rapid downtime. (+) as DC bus positive pole.
PB		
R	Inverter input terminal	Used for connecting 3PH AC power supply.
S		
T		
U	Inverter output terminal	Used for connecting motor.
V		
W		
	Ground connection	Ground terminal, ground resistance <math><10\Omega</math>
E		

The permutation and definition of main circuit terminal for AC70S (G1) series inverter

Chapter 3 Keyboard and Operation

3.1 Keyboard appearance and function



Key	Name	Function
	Menu key	Enter menu while standby or running. Press this key to return while modify parameter. While standby or running, press for 1 sec to enter condition monitoring interface.
	Confirm/modify key	Press to modify parameter while in menu interface. Press again to confirm after modifying. While standby or running, press to change LED monitoring items at stop.
	Up/down key	Select parameter group in menu interface. Modify parameter while in modify interface; Such as change the FE.14 parameter of lower limit leveling position tuning under standby or running monitoring state.
	Shift key	Used for select the function no.(changed by up/down key) when in menu interface. Used for select the parameter no.(changed by up/down key) when in modify parameter interface.
	Forward run key	While run/stop is controlled by keyboard, press this key, inverter forward rotate and the indicator is always on. While reverse, the indicator sparks.
	Jog/reverse key	This key function can be defined by parameter F4.01.Press it, machine reverse and indicator is off if this key is defined as REVE RSE.Machine will Jog-indicator is on if defined as JOG.
	Stop/reset key	Machine stop if press it while run/stop is controlled by key board. Its efficiency range is defined via function no.F4.02.Inverter reset if press it in fault state(no set if fault is not solved)

3.2 Indicator light meanings

	Name	State	Meaning
Unit indicator light	Hz	Spark	Digital display the given frequency.
	Hz	On	Digital display the output frequency.
	A	On	Digital display the actual output current.
	V	On	Digital display the input voltage.
	V	Spark	Digital display the output voltage.
	S	On	Time unit is second.
	S	Spark	Time unit is ms, min, or h.
	RPM	On	Digital display motor speed.
State indicator light	FWD	On	Inverter running in FORWARD
	FWD	Spark	Inverter running in REVERSE
	FWD	Off	Inverter stops.
Function indicator light	REV/JOG	On	JOG.
	REV/JOG	Off	Reverse.

Chapter 4 Function Parameter Table

“●”: Means that the parameter can be revised during frequency inverter in a running state

“○”: Means that the parameter cannot be revised when in a running state

4.1 Basic parameter

No.	Function description	Range of setting and definition	Factory default	Property
F0.00	Control mode	1: VC without PG 1	1	○
F0.01	Model selection	0: Integrated control system for construction hoist 1: Special frequency inverter for construction hoist 2: Special driver for construction elevator	2	○
F0.02	Run command channel	0: Keyboard control 1: Terminal control 2: RS485 communication control	1	○
F0.03	Frequency given main channel selection	0: Keyboard number given 6: RS485 communication port given	0	○
F0.08	Keyboard number giving frequency	0.00-Upper limit	50.00Hz	●
F0.09	Max. frequency output	0.00-320.00Hz	50.00Hz	○
F0.11	Upper limit frequency	0.00-320.00Hz	50.00Hz	○
F0.14	ACC time 1	0.01-650.00s	6.5s	●
F0.15	DEC time 1	0.01-650.00s	2.0s	●
F0.17	Carrier frequency	0.6-2.0KHz	1.0KHz	●
F0.18	Carrier frequency PWM characteristic selection	LED "0" digit: 0: Unrelated to temperature 1: Related to temperature LED "00" digit: 0: Unrelated to output frequency 1: Related to output frequency LED "000" digit: 0: Fixed carrier 1: Random carrier LED "0000": 0: PWM mode 1 1: PWM mode 2 2: PWM mode 3	1000	●
F0.19	Parameter initialization	0: No action 1: Recovery factory setting 2: Clear malfunction records	0	○
F0.20	AVR function selection	0: invalid 1: all valid 2: Invalid in DEC only	1	●
F1.08	DC braking start frequency during stopping	0.00-50.00Hz	3.50Hz	●
F1.09	DC braking current during stopping	0.0-150.0%	120.0%	●
F1.10	DC braking waiting time during stopping	0.0-60.0s	0.0s	●

F1.11	DC braking duration during stopping	0.0-60.0s	1.0s	●
F1.25	FWD/REV dead time	0.0-120.0s	0.1s	●
F1.26	Minimum output frequency	0.00-60.00Hz	1.90Hz	●
F1.27	0 speed hold torque	0.0-150.0%	120.0%	●
F2.00	Multifunction input terminal 1(X1)	0: No function 1: FWD 2: REV 5:REV JOG 6:Free stop 7:Emergency stop 8:Fault reset 11:Frequencies decrease (DW) 15: Multistage speed terminal 1 16: Multistage speed terminal 2 17: Multistage speed terminal 3 18: Multistage speed terminal 4 48: Lower limit input terminal 49: Upper limit input terminal	1	●
F2.01	Multifunction input terminal 2(X2)		2	●
F2.02	Multifunction input terminal 3(X3)		48	●
F2.03	Multifunction input terminal 4(X4)		49	●
F2.04	Multifunction input terminal 5(X5)		6	●
F2.05	Multifunction input terminal 6(X6)		8	●
F2.06	Multifunction input terminal 7(X7)		8	●
F2.07	Multifunction input terminal 8(X8)		11	●
F2.29	Output terminal 1(Y1)		0: No output 3:Fault trip alarm 1(alarm while fault self-recover) 20:Hoist band-brake logic control 29: Phase fault output	3
F2.30	Output terminal 2(Y2)	29		●
F2.31	Relay output terminal(TA/TC)	20		●
F2.32	Upward start frequency	0.00-50.00Hz	4.50Hz	●
F2.33	Upward start frequency delay time	0.00-10.00s	0.7s	●
F2.34	Upward brake releasing current value	0.00-500.00%	100.00%	●
F2.35	Upward brake releasing current duration	0.00-10.00s	0.10s	●
F2.36	Downward start frequency	0.00-50.00Hz	3.50Hz	●
F2.37	Downward start frequency delay time	0.00-10.00s	0.5s	●
F2.38	Downward brake releasing current value	0.00-500.00%	100.00%	●
F2.39	Downward brake releasing current duration	0.00-10.00s	0.10s	●
F2.40	Upward stop-band brake frequency	0.00-50.00Hz	2.00Hz	●
F2.41	Upward stop-band brake delay time	0.00-10.00s	0.35s	●
F2.42	Downward stop-band brake frequency	0.00-50.00Hz	2.00Hz	●
F2.43	Downward stop-band brake delay time	0.00-10.00s	0.35s	●
F2.44	Loose-brake signal output delay	0.00-10.000s	0.150s	●
F2.45	Band-brake signal output delay	0.00-10.000s	0.050s	●

F3.15	Vector 1 mode setting		0032	○
F4.01	User password	0000~9999	****	
F4.05	Function parameter copy	0: No operation 1: Upload parameter from inverter to keyboard and save 2: Upload parameter from keyboard to inverter and save	0	○
F4.11	The display content of the first line at the running state	LED "0" digit: display the first group 0: Given frequency 1: Output frequency 2: Output current 3: Input voltage 4: Output voltage 5: Mechanical speed 6: Input terminal state 1 7: Reserved 8: Reserved 9: Reserved A: Output power B: DC bus voltage C: Module temperature 1 D: Module temperature 2 E: ON/OFF state of input terminal X F: ON/OFF state of output terminal Y LED "00" digit: display the second group LED "000" digit: display the third group LED "1000": display the fourth group	3215	
F4.12	The display content of the first line at the stop-state	LED "0" digit: display the first group LED "00" digit: display the second group LED "000" digit: display the third group LED "0000": display the fourth group	3215	
F4.13	The display content of the second line at the running state	LED "0" digit: display the first group LED "00" digit: display the second group LED "000" digit: display the third group LED "0000": display the fourth group	0E26	
F4.14	The display content of the second line at the stop-state	LED "0" digit: display the first group LED "00" digit: display the second group LED "000" digit: display the third group LED "0000": display the fourth group	0E26	
F4.15	Torque compensation coefficient	0.0-5000.0%	30.0%	●
F5.01	Motor poles	2-48	4	○
F5.02	Motor rated power	0.4-1000.0kW	33kW	○
F5.03	Motor rated frequency	0.01-Max. frequency	50	○
F5.04	Motor rated speed	0-65000rpm	1390rpm	○
F5.05	Motor rated voltage	0-1500V	380V	○
F5.06	Motor rated current	0.1-2000.0A	55.6A	○
F5.07	Motor no-load current	0.01-650.00A	20.97A	○
F5.08	Motor stator resistance	0.001-65.000	0.103	○
F5.09	Motor Rotor resistance	0.001-65.000	0.083	●

F5.10	Motor stator-rotor inductance	0.1-6500.0mH	33.2mH	●
F5.11	Motor stator-rotor mutual inductance	0.1-6500.0mH	32.0mH	●
F5.12	Motor parameter self-adjustment selections	0: No operation 1: Rotary self learning 2: Static self learning	0	●
F5.13	Rated field voltage ratio	0-1000	200	○
F5.14	Torque component	0-1000	600	○
F8.12	Torque boost	0.1-30.0%	0.0%	○
F8.14	V/F slip compensation	0.0-200.0%	0.0%	●
Fb.00	0 current running alarm selection	"0" digit: Run enabled signal abnormal alarm 0: invalid 1:valid "00" digit: 0 current running alarm selection 0: invalid 1:valid	0011	○
Fb.01	0 current running filter time	0.020-1.000	0.100	●
Fb.02	0 current running judge threshold value	0-1000	200	○
Fb.03	Low voltage self-adaptation filter coefficient	10-5000	500	●
Fb.04	Low voltage self-adaptation function selection	LED single digit: Low voltage self-adaptation function 0: invalid 1:valid LED tens digit: Reserved LED hundreds digit: Reserved LED thousands digit: Reserved	0000	●
Fb.05	The starting voltage of low voltage frequency down	0.0-100.0%	90.0%	○
Fb.06	The recovery voltage of low voltage frequency down	0.0-100.0%	92.0%	●
Fb.07	The deviation adjustment of low voltage frequency	0.0-20.0%	5.0%	●
Fb.08	High speed gear frequency	0.00-200.00Hz	50.00Hz	●
Fb.09	Light-load frequency raising function selection	LED "0" digit: Light-load frequency raising function frequency function 0: invalid 1:Judged by the current 2:Judged by the weight LED "00" digit: Reserved	0000	●
Fb.10	Load calculating time	0.000-10.000s	1.000s	●
Fb.11	Exit judgment current 1 when raise frequency	0.0-150.0%	100.0%	●

Fb.12	Exit judgment current 2 when raise frequency	0.0-150.0%	50.0%	●
Fb.13	Upward over frequency limit	0.00-100.00Hz	15.00Hz	●
Fb.14	Downward over frequency limit	0.00-100.00Hz	15.00Hz	●
Fb.15	Upward raising frequency judgment value	0.0-100.0%	65.0%	●
Fb.16	Downward raising frequency judgment value	0.0-100.0%	45.0%	●
FE.03	Deceleration optimization function selection	0: invalid 1:valid	1	●
FE.04	Linear speed	0.0-200.0(m/min)	34.0	●
FE.05	The frequency corresponded with linear speed	0.0-100.00Hz	50.00Hz	●
FE.06	Deceleration stop distance	0.000-3.000m	0.500m	●
FE.07	Deceleration optimization model selection	LED single digit: maintaining frequency deceleration mode selection when greater than the lower limit state 0: Segmented deceleration stop LED tens digit: maintaining frequency deceleration mode selection when less than the lower limit state 0: Segmented deceleration stop 1: Run with FE.08 frequency LED hundreds digit: When the upper limit is invalid, the stop mode selection 0: Free stop 1: Deceleration stop LED thousands digit: After deceleration finished, if the inverter is still in lower limit state, the downward command selection 0: Maintain DC braking, downward valid after stop or upward 1: Invalid, valid after lower limit exited	1000	●
FE.08	Lower limit frequency of lower limit state	0.0-20.00Hz	5.00Hz	●
FE.09	Maintaining frequency in lower limit state	0.0-20.00Hz	15.00Hz	●
FE.10	Segmented deceleration distance 1	0.0-100.0%	70.0%	●
FE.11	Segmented deceleration distance 2	0.0-100.0%	20.0%	●
FE.12	Linear speed calibration coefficient	0.0-200.0%	100.0%	●
FE.13	Deceleration optimization compensation coefficient	0.0-200.0%	20.0%	●
FE.14	Lower limit leveling position tuning	0.000-0.300m	0.15m	●
FE.15	Reserved			●

F9.16	Phase to phase times when lose phase	0-128	4	●
F9.17	0 current threshold of each phase	0.0-200.00%	2.00%	●
FA.01	Protection function selection 2	LED "0" digit: DEC over-voltage protection selection 0: Invalid 1: Rating 1 over-voltage protection 2: Rating 2 over-voltage protection	0000	●
FA.02	Protection function selection 3	LED "0" digit: Inverter OH protection selection 0: Emergency stop (free stop) and alarm 1: Emergency stop and alarm 2: Run with limiting current LED "00" digit: input phase lose protection selection 0: Invalid 1: valid LED "000" digit: Output lack phase protection selection 0: Invalid 1: Lack phase detection valid, no open brake signal 2: Lack phase detection valid, associated with open brake LED thousands digit: Reserved	0210	●
FA.03	Protection function selection 4	LED "0" digit: SC interference suppression 0: Invalid 1: valid LED "00" digit: Overcurrent interference suppression 0: Invalid 1: valid LED "000" digit: Reserved LED "0000" digit: Reserved	0000	●
FA.04	FAN control	0: Fan runs after inverter is power on 1: Fan stops related to temperature, Fan runs after inverter starts running 2: Fan stops after inverter stops, Fan runs related to temperature.	1	●
FA.08	Energy consumption braking action voltage	115.0-140.0%	120.0%	●
FA.10	DC bus under voltage protection point	50.0~100.0%	70.0%	●
FA.15	ACC overcurrent suppression point	100~250%	160%	●
FA.16	DEC overcurrent suppression point	100~250%	160%	●
FA.17	Current limit amplitude in the running state	100~250%	160%	●
FA.18	Current limit amplitude frequency ACC/DEC time	0.01~650.00s	10.00s	●

FA.25	Malfunction types	See malfunction code table	--	x
FA.26	Malfunction running frequency	0.00-Max. frequency	--	x
FA.27	Malfunction output voltage	0-1500V	--	x
FA.28	Malfunction output current	0.1-2000.0A	--	x
FA.29	Malfunction bus voltage	0-3000V	--	x
FA.30	Malfunction module temperature	0-100℃	--	x
FA.31	Malfunction inverter state	LED "0" digit: Running direction 0: Forward 1:Reverse LED "00" digit: Running state 0: Stop 1: Steady speed 2: ACC 3: DEC LED "000" digit: Reserved LED "0000" digit: Reserved	--	x
FA.32	Malfunction input terminal state	See input terminal chart	--	x
FA.33	Malfunction output terminal state	See output terminal chart	--	x
FA.34	The last malfunction type	See malfunction code table	--	x
FA.35	The last malfunction running frequency	0.00-Max. frequency	--	x
FA.36	The last malfunction output voltage	0-1500V	--	x
FA.37	The last malfunction output current	0.1-2000.0A	--	x
FA.38	The last malfunction bus voltage	0-3000V	--	x
FA.39	The last malfunction module temperature	0-100℃	--	x
FA.40	The last machine state	LED "0" digit: Running direction 0: FWD 1: REV LED "00" digit: Running state 0: Stop 1: Steady speed 2: ACC 3: DEC LED "000" digit: Reserved LED "0000" digit: Reserved	--	x
FA.41	The last malfunction input terminal state	See input terminal chart	--	x
FA.42	The last malfunction output terminal state	See input terminal chart	--	x
FA.43	The last two malfunction types	See malfunction code table	--	x
FA.44	The last three malfunction types	See malfunction code table	--	x

Note: Except the special definition function, more details for the rest functions please refer to the <AC80B series frequency inverter manual.

4.2 Special Function Description

4.2.1 Light-Load Speed Rising Function

No.	Function description	Range of setting and definition	Factory default
Fb.08	High speed frequency	0.00-200.00Hz	50.00Hz
Fb.09	Light-load frequency rising function selection	LED "0" digit: Light-load frequency rising function 0: invalid 1: Judged by the current 2: Judged by the weight	0000
Fb.10	Load calculating time	0.000-10.000s	1.000s
Fb.11	Exit judgment current 1 when frequency rising	0.0-150.0%	100.0%
Fb.12	Exit judgment current 2 when frequency rising	0.0-150.0%	50.0%
Fb.13	Upward over frequency limit	0.00-100.00Hz	15.00Hz
Fb.14	Downward over frequency limit	0.00-100.00Hz	15.00Hz
Fb.15	Upward frequency rising judgement value	0.0-100.0%	65.0%
Fb.16	Downward frequency rising judgement value	0.0-100.0%	45.0%

When the output frequency is equal to Fb.08, the frequency rising will be judged after maintaining the setting time Fb.10, and it will be performed if the frequency rising conditions are satisfied. Taking the current judgement as an example: the frequency will rise if the output current (Percentage of the motor rated current) is less than Fb.15 while going up, and the rising value is determined by Fb.13; the frequency will also rise if the output current (Percentage of the motor rated current) is less than Fb.16 while going down, and the rising value is determined by Fb.14. The frequency rising will be exited if the current is more than exit judgement current. 50Hz corresponds to Fb.11, 100Hz corresponds to Fb.12 and the exit judgement current can be calculated linearly with the output frequency.

4.2.2 Low Voltage Self-adaptation Function

No.	Function description	Range of setting and definition	Factory default
Fb.03	Low voltage self-adaptation filter coefficient	10-5000	500
Fb.04	Low voltage self-adaptation function selection	LED "0" digit: Low voltage self-adaptation function 0: invalid 1: valid	0000
Fb.05	The starting voltage of low voltage frequency down	0.0-100.0%	90.0%
Fb.06	The recovery voltage of low voltage frequency down	0.0-100.0%	92.0%
Fb.07	The deviation adjustment of low voltage frequency	0.0-20.0%	5.0%

If the bus voltage is less than Fb.05, reduce the output frequency properly to prevent the motor from entering weak-magnetic area at high frequency, which effectively guarantees the output torque of motor. Exit frequency-down if the bus voltage is more than Fb.06, and accelerate to the given frequency according to ACC time.

4.2.3 Deceleration Optimization Function (Lower limit leveling optimization)

No.	Function description	Range of setting and definition	Factory default
FE.03	Deceleration optimization function selection	0: invalid 1: valid	1
FE.04	Linear speed	0.0-200.0(m/min)	34.0
FE.05	The frequency corresponded with linear speed	0.0-100.00Hz	50.00Hz
FE.06	Deceleration stop distance	0.000-3.000m	0.500m
FE.07	Deceleration optimization model selection	LED "0" digit: Deceleration mode selection when more than the lower limit maintaining frequency 0: Segmented deceleration stop LED "00" digit: Deceleration mode selection when less than the lower limit maintaining frequency 0: Segmented deceleration stop 1 : Run at FE.08 frequency LED "000" digit: Stop mode selection when the upper limit is invalid, 0: Free stop 1: Deceleration stop LED "0000" digit: After deceleration finished, if the inverter is still in lower limit state, the downward command selection 0: Maintain DC braking, downward valid after stop or upward 1: Invalid, and only valid after lower limit exited	1000
FE.08	Lower limit frequency at lower limit downward state	0.0-20.00Hz	5.00Hz
FE.09	Maintaining frequency at lower limit state	0.0-20.00Hz	15.00Hz
FE.10	Segmented deceleration distance 1	0.0-100.0%	70.0%
FE.11	Segmented deceleration distance 2	0.0-100.0%	20.0%
FE.12	Linear speed calibration coefficient	0.0-200.0%	100.0%
FE.13	Deceleration optimized compensation coefficient	0.0-200.0%	20.0%
FE.14	Fine adjustment of leveling at lower limit	0.000-0.300m	0.150m

Deceleration optimization function: Used for lower limit leveling optimization. When it is valid, the normal lower limit stop distance can be set by FE.06. When the leveling error is within 150mm, the FE.14 (fine adjustment of leveling at lower limit) can be modified directly with the up/down keys.

4.3 Monitor code

Press "PRG" key for more than 2 seconds to enter "C" parameters group.

No.	Function name	Unit of setting and definition
C-00	Given frequency	0.01Hz
C-01	Output frequency	0.01Hz
C-03	Output current	0.1A
C-03	Input voltage	0.1V
C-04	Output voltage	0.1V

C-05	Machinery speed	1RPM
C-06	Input terminal state 1	See the introduction
C-07	Reserved	
C-08	Reserved	
C-09	Reserved	
C-10	Reserved	
C-11	Bus voltage	0.1V
C-12	Module temperature 1	0.1°C
C-13	Module temperature 2	0.1°C
C-14	Input terminal X on- state	Refer to input terminal state diagram
C-15	Output terminal Y on- state	Refer to output terminal state diagram
C-25	Inverter power level	kW
C-26	Inverter rated voltage	V
C-27	Inverter rated current	A
C-28	Software edition	

Input terminal on/off state diagram:

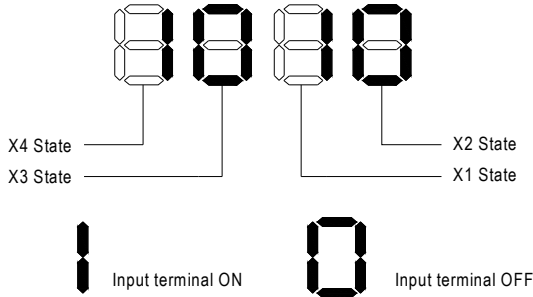

Input terminal ON/OFF state diagram

The second line displayed on panel (C-06 input terminal state 1):

LED "0" digit:

0: downward command disconnected

1: downward command connected

LED "00" digit:

0: upward command disconnected

1: upward command connected

LED "00" digit:

0: Downward command is invalid at lower limit state.

1: Not at lower limit state

LED "0000" digit:







0: Upward command is invalid at upper limit state.











1: Not at upper limit state

Chapter 5 Fault Information

5.1 Fault Information

Keyboard display	Fault code	Fault type	Possible causes	Treatment
LU1	L.U.1	Too low power voltage	<ul style="list-style-type: none"> Power supply is too low Voltage detection circuit is abnormal 	<ul style="list-style-type: none"> Check input power to eliminate the fault. Seek support from factory.
ELU2	E.LU2	Too low voltage in operation	<ul style="list-style-type: none"> Power supply is too low. Power capacity is too low, or there is big impact current in the power grid. Inner DC main contactor is not closed. 	<ul style="list-style-type: none"> Check input power to eliminate the fault. Improve power-supply system. Seek support from factory.
E.oU1	E.oU1	ACC over-voltage	<ul style="list-style-type: none"> Power voltage fluctuation over limit. Start running motor. 	<ul style="list-style-type: none"> Detect power voltage and eliminate fault. Restart motor until it totally stops. Set F1.00 to 1or 2.
E.oU2	E.oU2	DEC over-voltage	<ul style="list-style-type: none"> Deceleration time is too short. Load potential energy or inertia is too large. Power voltage fluctuation over limit. 	<ul style="list-style-type: none"> Prolong deceleration time properly. Reduce load inertia or improve inverter capacitance or add braking unit. Detect input power and clear fault.
E.oU3	E.oU3	Constant speed over-voltage	<ul style="list-style-type: none"> Power voltage fluctuation over limit. 	<ul style="list-style-type: none"> Detect input power voltage and eliminate fault. Install input reactor.
E.oU4	E.oU4	Overvoltage while stop	<ul style="list-style-type: none"> Power voltage fluctuation over limit. 	<ul style="list-style-type: none"> Check input power to eliminate fault. Seek support from factory.
E.oC1	E.oC1	ACC overcurrent	<ul style="list-style-type: none"> Acceleration time is too short. Start running motor. V/F curve setting is not suitable. Or torque boost too high. Inverter capacitance is too small. 	<ul style="list-style-type: none"> Prolong ACC time. Restart motor until it totally stop. Set F1.00 to 1or 2. Reset V/F curve or torque boost value. Select inverter with right capacitance.
E.oC2	E.oC2	DEC overcurrent	<ul style="list-style-type: none"> Deceleration time is too short. Load potential energy or inertia is too large. Power voltage fluctuation over limit. 	<ul style="list-style-type: none"> Prolong deceleration time. Connect external braking resistance or braking unit. Select inverter with right capacitance.

	E.oC3	Constant speed overcurrent	<ul style="list-style-type: none"> ● Sudden load change. ● Power grid voltage is too low. 	<ul style="list-style-type: none"> ● Check load change and eliminate it. ● Check input power to eliminate fault.
	E.oL1	Motor over-load	<ul style="list-style-type: none"> ● V/F curve setting is not suitable. Or torque boost too high. ● Power grid voltage is too low. ● Incorrect overload protection setting. ● Locked-rotor run or too heavy load. ● Universal motor long time low speed operation. 	<ul style="list-style-type: none"> ● Reset V/F curve or torque boost value. ● Check input power to eliminate fault. ● Unreasonable F5.06/18 setting. ● Adjust load or select inverter with right capacitance. ● If need long low-speed operation, please choose special motor for inverter.
	E.oL2	Inverter over-load	<ul style="list-style-type: none"> ● Load is too heavy. ● Acceleration time is too short. ● Start running motor. ● V/F curve setting is not suitable. Or torque boost too high. 	<ul style="list-style-type: none"> ● Select inverter with right capacitance. ● Prolong acceleration time ● Restart motor until it totally stop. Set F1.00 to 1or2. ● Reset V/F curve or torque boost value.
	E.SC	System abnormality	<ul style="list-style-type: none"> ● Acceleration time is too short. ● Short circuit between inverter output phases or earth. ● Module is damaged. ● Electromagnetic disturbance. 	<ul style="list-style-type: none"> ● Prolong acceleration time properly. ● Check periphery equipment and restart after fault eliminating. ● Seek support from factory. ● Check system wiring, earth, shield and deal as required.
	E.oH1	Inverter over-heat	<ul style="list-style-type: none"> ● Temperature is too high. ● Air channel is blocked. ● Fan connection parts are loose. ● Fan is damaged. ● Temperature detection circuit fault 	<ul style="list-style-type: none"> ● Make the environment meet the requirement. ● Clear the air channel. ● Check and reconnect the wire ● Change the same new fan. ● Seek support from factory.
	E.oH2	Rectifier over-heat	<ul style="list-style-type: none"> ● Temperature is too high. ● Air channel is blocked. ● Fan connection parts are loose. ● Fan is damaged. ● Temperature detection circuit fault 	<ul style="list-style-type: none"> ● Make the environment meeting the requirement. ● Clear the air channel. ● Check and reconnect the wire. ● Change the same new fan. ● Seek support from factory.
	E.TE1	Motor static detection fault	<ul style="list-style-type: none"> ● Detection overtime ● Start static detection while motor is running. ● Capacitance difference is 	<ul style="list-style-type: none"> ● Check motor connection wire. ● Detect after motor stopping totally. ● Change inverter model.

			<p>too big between motor and inverter.</p> <ul style="list-style-type: none"> ● Motor parameter setting mistake. 	<ul style="list-style-type: none"> ● Reset parameter according to nameplate.
	E.TE2	Motor rotation detection fault	<ul style="list-style-type: none"> ● Detect while motor is running. ● Detect with load. ● Detection overtime ● Capacitance difference is too big between motor and inverter. ● Motor parameter setting mistake. 	<ul style="list-style-type: none"> ● Detect after motor stop totally. ● Re-detect without load. ● Check motor connection wire. ● Change inverter model. ● Reset parameter according to nameplate.
	E.EEP	Memory fault	<ul style="list-style-type: none"> ● Electromagnetic disturbance in memory period. ● EEPROM damage. 	<ul style="list-style-type: none"> ● resume load and save. ● Seek support from factory.
	LIFE	GPRS action	<ul style="list-style-type: none"> ● 	<ul style="list-style-type: none"> ● Seek support from factory.
	E.ILF	Input side open phase	<ul style="list-style-type: none"> ● 3-phase input power phase failure. 	<ul style="list-style-type: none"> ● Check 3-phase power supply and the phase. ● Check 3-phase power supply wiring.
	E.oLF	Ouput side open phase	<ul style="list-style-type: none"> ● 3-phase output power phase failure. 	<ul style="list-style-type: none"> ● Check 3-phase output voltage and current. ● Check wiring.
	E.HAL	Current detection fault	<ul style="list-style-type: none"> ● Detect circuit fault. ● Phase imbalance 	<ul style="list-style-type: none"> ● Seek for technical support. ● Check motor and wiring.
	E.EF	GPS action	<ul style="list-style-type: none"> ● GPS action remote control 	<ul style="list-style-type: none"> ● Seek support from factory
	E.PAn	Keyboard connect fault	<ul style="list-style-type: none"> ● Keyboard wire fault. ● Keyboard component damage. 	<ul style="list-style-type: none"> ● Check keyboard wire. ● Seek support from factory.
	E.CE	Rs485 communication fault	<ul style="list-style-type: none"> ● Unsuitable baud rate setting. ● Communication wire breaks. ● Communication format does not match upper machine. 	<ul style="list-style-type: none"> ● Set suitable baud rate setting. ● Check communication wire. ● Set right communication format.
	E.CPE	Parameter copy fault	<ul style="list-style-type: none"> ● Parameter copy communication is fault. ● Keyboard wiring fault. 	<ul style="list-style-type: none"> ● Check wiring. ● Seek support from factory.
	E.Fb2	0 current running fault	<ul style="list-style-type: none"> ● Wiring fault between motor and inverter ● Current detection fault 	<ul style="list-style-type: none"> ● Check motor wiring. ● Check haul wire interface ● Seek support from factory

Chapter 6 Debugging Instructions

6.1 Debugging Steps

➤ **Installation wiring 1, as shown below:**

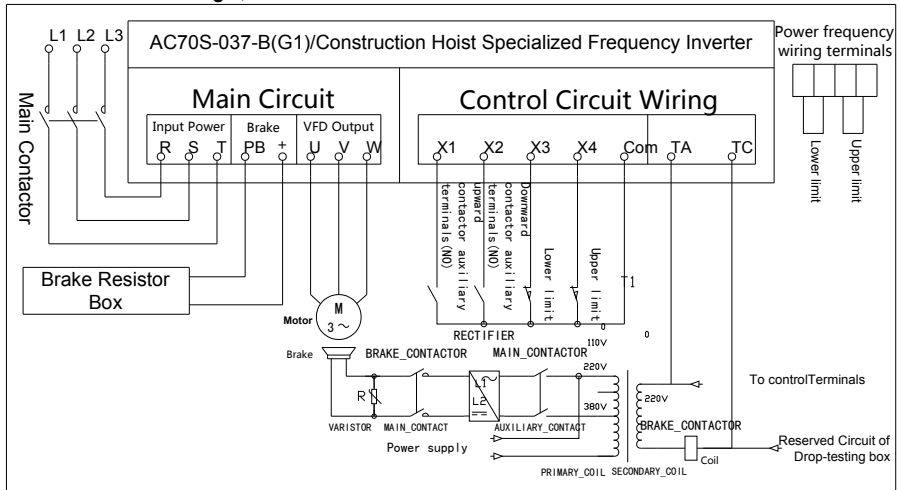

Installation wiring steps:

The 1st and 3rd step refer to the main circuit wiring diagram.

1. Connect R\|S\|T to the output terminals of main contactor; (Wrap the original wires);
2. Connect the motor cables to U\|V\|W terminals of inverter;
3. Connect the braking resistance to the PB\|+ terminals of inverter;

The 4th and 6th step refer to the control circuit wiring diagram.

4. Connect the upper limit to X4 and COM of the control board, and connect the lower limit to X3 and COM of the control board (Remove the upper/lower limit switch, and short the original terminals);
5. Connect X1\|COM with the normally open contacts of up contactor, and connect X2\|COM with the normally open contacts of down contactor (Remove the wires of normally open contact of original up/down contactors and wrap them well);
6. Connect the TC terminal of control board with one end of the braking contactor coil, and connect the TA terminal with the secondary end of transformer (Obtain the control power), ensuring that the braking main circuit is only controlled by main contactor and braking contactor. And retain the drop test box circuits which are directly connected with the braking contactor coil;
7. The phase sequence protector in the original power frequency box is short connected (there is phase sequence protection function in inverter. If not short, it may cause the phase sequence protector misoperation, leading to the OC fault). If there is a delayed head, turn to zero.
8. Set the lower limit of cam 30 cm higher, and perform fine adjustment of bottom position through the up/down keys of keyboard

6.2 Debugging Precautions

- (1) Make sure that the power line, motor cables and control lines are well connected;
- (2) Check whether the control command signal and the limit signal is valid or not;
- (3) Move the lower limit of cam 30cm higher;
- (4) Test deceleration optimization function: if there is a certain distance to the leveling after the deceleration optimization, users can finely adjust through FE.06 (range of ± 5 cm or so).

6.3 Problems & Solutions in the Debugging Process

Problem 1: Pushing operation handle up to give upward command and pushing the operation handle down to give downward command, inverter does not work.

- (1) Pushing operation handle up but without running: if the second line of the panel—"0000" digit displays "1" and "00" digit displays "0"—please check the upward command wiring; if the "0000" digit displays "0", please check whether the limit is at upper limit state.
- (2) Pushing operation handle down but without running: if the second line of the panel—"000" digit displays "1" and "0" digit displays "0"— please check the downward command wiring; if the "000" digit displays "0", please check whether the limit is at lower limit state.

Problem 2: If shutdown occurs during the deceleration optimization process and the cage cannot reach to precise position, please adjust the FE.06 parameter setting.

VEICHI

SUZHOU VEICHI ELECTRIC CO.,Ltd.

Address:No.1000 Songjia road,Wuzhong Economic and
Technological Development Zone,Suzhou

Phone:+86-512-6617 1988

Facebook:<https://www.facebook.com/veichigroup>

Whatsapp:+86-138 2881 8903

E-mail:overseas@veichi.com Web:<https://www.veichi.org/>



Official Website

Version: 2021 V1.2