

HMI Series

Model: VI30-043-ANL-EN

Product Overview

The VEICHI VI30 series is a new generation of HMI in an industrial ABS plastic casing, ensuring reliability. It presents a sleek new front design and offers higher-resolution model options.

Product Appearance



Product Specifications

Characteristics	Display screen	4.3"16:9 TFT LED screen
	Resolution	480x272
	Color	65536
	Brightness	250 cd/m ²
	Touch screen	4-wire resistive type
	Input voltage	24 ₋ +20%VDC
	Rated power	4W
	Processor	ARM9 600MHz
	Memory	64M
	Data storage	8M
	Hardware clock	Built-in
External Interface	Serial port	COM2 (RS485)
	USB	1×Host
	Ethernet	None
Environment	Temperature	0°C~45°C
	Operating humidity	5%~90%(non-condensing)
	Storage temperature	-10°C~60°C
	Storage humidity	5%~90%(non-condensing)

Specification	Casing material	Industrial plastics
	Casing color	Industrial black
	Panel dimensions (mm)	130×104
	Cabinet aperture(mm)	120×93
Certification	Certification	CE/FCC
	IP	IP65 (front panel)
	EMC	Level 3

Wiring Definition



Touch Screen Serial Interface Definition

Communication Cable

Power supply	24+ _20% VDC
RS485	Set to com2 in the software
USB	Used to connect a USB flash drive, download programs, and export stored data
Communication cable	3m cable: red (485 A+) blue (485 B-)

Dimensions

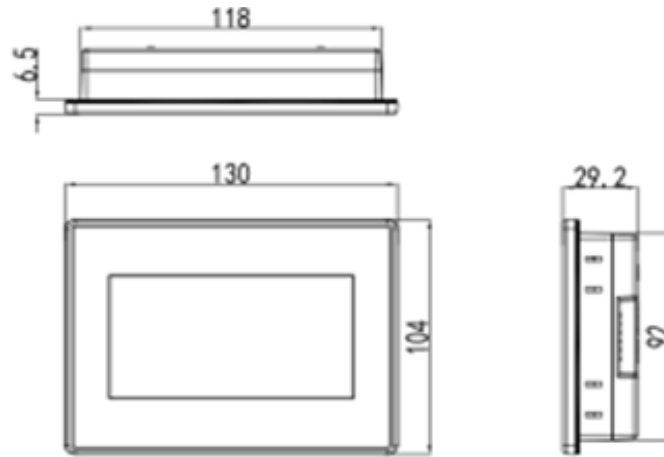

Overall Dimensions

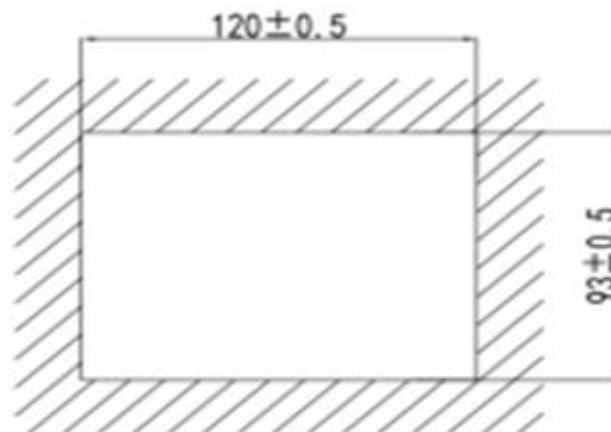

Hole Size

Embedded installation hole size: 120*93(mm)

Contacts

Suzhou (Headquarter)

Address: No.1000 Songjia Road, Wuzhong Economic and Technological Development Zone, Suzhou, Jiangsu Province, China.

Tel: 0512-66171988

Fax: 0512-66173610

Shenzhen (Subsidiary)

Address: 3rd Floor, Building ChunSheng, Lingya Industrial Park, No. 1 Road, Tangtou Community, Shiyan Street, Baoan District, Shenzhen, China.

Tel: 0755-36861688

Fax: 0755-29685680