

#### 4. Failure reasons and troubleshooting method

Fault phenomenon	Reasons	Solutions
Motor: out of operation	<ol style="list-style-type: none"> <li>1. Too much low voltage leads to failed start-up;</li> <li>2. Stuck impeller or stator and rotor;</li> <li>3. Three-phase electric pump: power phase shortage;</li> <li>4. The welding lines of capacitor and protector fall off or to be burnt;</li> <li>5. Burnt stator winding or open circuit.</li> </ol>	<ol style="list-style-type: none"> <li>1. Use a voltage regulator for further adjustment;</li> <li>2. Check causes and then take the corresponding measures;</li> <li>3. Take off the water inlet valve to clean stoppers of impellers as well as silt of sand-proof cover;</li> <li>4. Find reasons for phase shortage and then take measures for normal three-phase power;</li> <li>5. Re-weld falling wires or change damaged parts;</li> <li>6. Send to maintenance unit to replace or repair windings.</li> </ol>
No water or not enough water amount	<ol style="list-style-type: none"> <li>1. Too much low voltage leads to not enough rotation or reduced water amount;</li> <li>2. Too high lift that has exceeded electric pump's lift capacity;</li> <li>3. Wrong impeller rotation;</li> <li>4. Serious wear of impellers;</li> <li>5. Open circuit of stator winding.</li> </ol>	<ol style="list-style-type: none"> <li>1. Adjust voltage;</li> <li>2. Decrease lift or buy another electric pump according to practical situation;</li> <li>3. Exchange position of two power lines;</li> <li>4. Clean blocked sundries;</li> <li>5. Change impeller or send it to maintenance unit;</li> <li>6. Send it to maintenance unit for further repair.</li> </ol>
Frequently worked protectors	<ol style="list-style-type: none"> <li>1. Too much low voltage leads to increased current and serious motor heating;</li> <li>2. Too much low lift leads to increased water drainage and serious motor overload;</li> <li>3. Abnormal wear of rotors or parts;</li> <li>4. The electric pump is exposed above water or operated in a dry environment;</li> <li>5. Damaged sealing; water inflow of machine winding;</li> <li>6. Serious bearing wear (too much big noise) and increased friction force.</li> </ol>	<ol style="list-style-type: none"> <li>1. Adjust voltage;</li> <li>2. Use iron wire to narrow water outlet so as to reduce outflow;</li> <li>3. Adjust or replace parts;</li> <li>4. Reduce installation height;</li> <li>5. Replace sealing element and dry the electric machine;</li> <li>6. Replace bearing.</li> </ol>

## SUBMERSIBLE PUMP FOR DEEP-WELL OPERATION MANUAL



**Important attention:**  
**Before put the pump into the well,**  
**the pump should full fill with water.**

## CONTENTS

---

Warning .....	1
Introduction .....	2
Use condition .....	2
Installation use and notice .....	2
Failure reasons and troubleshooting method .....	9

## Motor inspection

6", 8" and 10" water-filled submersible motors are filled with clean and neutral water before using. If the surface of the motor is overheated after operation or the sensor shows that the temperature rises too fast, it is necessary to check the cooling filling liquid in the motor. When filling the liquid, unscrew the filling screw at the top of the motor (if there are exhaust screws on the opposite side, it needs to be unscrewed at the same time), use the injector to fill until it is full, and then tighten the sealing screw. And no-load motor test, motor test, people do not close to the motor, careful motor shaft extension (if necessary, for motor type test).

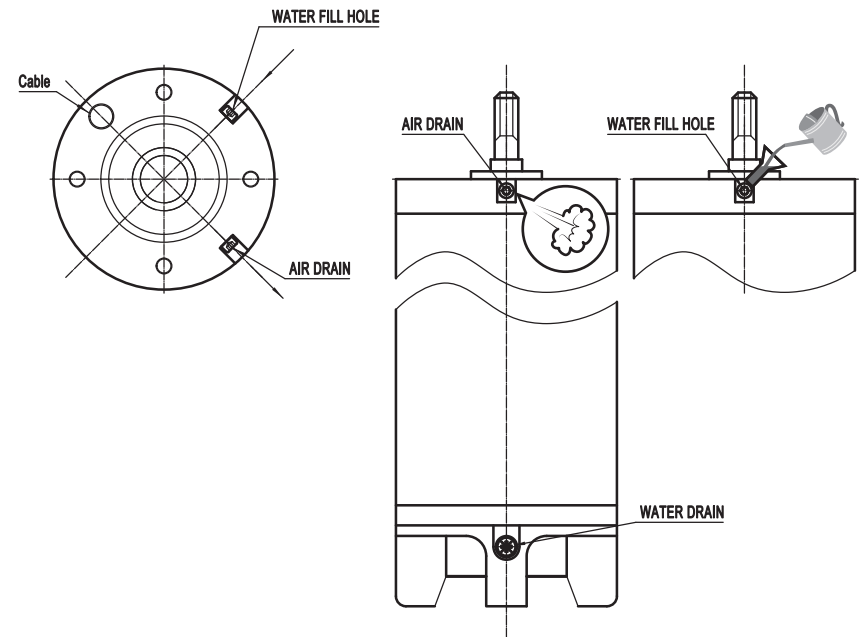

## **⚠ WARNING**

### **Motor must be filled with water before using!**

- Step 1: Setting motor vertically
- Step 2: Both unscrew the filling screw and exhaust screw
- Step 3: Filling water from water fill hole
- Step 4: At the same time, the air will be exhausted from air drain hole
- Step 5: Until the water overflows from air drain hole
- Step 6: Waiting 5 mins to avoid air doesn't exhaust fully
- Step 7: Screwing air drain hole and water fill hole

**Thank you for buying our water pumps. Please read the operation manual carefully before using.**

## **⚠ WARNING**

- The reliable grounding must be conducted before using water pumps. The earth leakage protective device as well as overload or over-current protective device must be installed on water pumps.
- The electric pump is not allowed for dry running.
- When the pump is in operation, people and animals shall not touch the water near the pump.
- In order to prevent electrical shock, the power source shall be shut off during maintenance and cleaning.

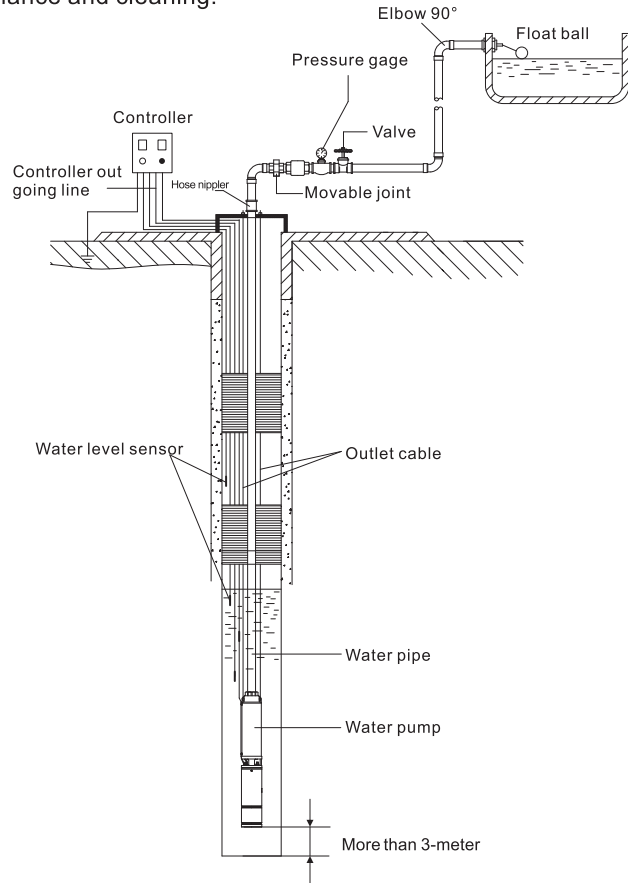

The above installation structure is for reference only. Please purchase the matching parts shown in the figure by yourself.

## **1. Introduction**

The deep-well pump is a water lifting tool based on direct connection between electric machine and water pump, which is suitable to fetch underground water from deep wells or rivers, reservoirs and canals etc in some projects. Further, this product is mainly used for farmland irrigation as well as human and animal drinking water in plateau mountain areas. More importantly, the deep-well pump can be used for water supply and discharge in cities, factories, railways, mines and construction sites.

## **2. Use condition**

- 2.1 Voltage fluctuating range shall be  $\pm 10\%$  of rated values;
- 2.2 The water temperature shall not be higher than  $+25^{\circ}\text{C}$ .
- 2.3 The PH value of water is between 6.5 and 8.5.
- 2.4 The solid contents in the water shall not be larger than 0.25% with the maximum diameter not over 2.3mm.

## **3. Installation use and notice**

- 3.1 Please check whether the inner diameter conforms to the minimum diameter of water pumps before buying and installing. If it is a new well, the air compressor or old water pump shall be used to clean sundries and soils. After that, please check whether the water quality and temperature conform to use conditions. The water pump can only be installed with the water inside the well up to standard.
- 3.2 Please check damage that may be caused in the transportation and storage process after unpacking the pump. For example, whether the cable and plug etc are intact; various joints are not loosened without any leakage. If with any damage, please contact with professional personnel to repair or replace it.
- 3.3 During installation, please fix the electric pump and then install earth leakage protective device or over-voltage or over-current protective device correctly. The electric pump must be connected to ground reliably.

3.4 When the water pump reaches a certain length, the motor and the pump body need to be packed separately.

● In case of a separate packing, first remove the filter screen and cable protection plate from the pump body (Figure 1), then place the pump body on the motor to make the spindle head of the rotor smoothly slide into the coupling, manually rotate the coupling to check if it can run normally, then screw up the connecting bolt (Figure 2), and finally install the filter screen and cable protection plate (Figure 3).

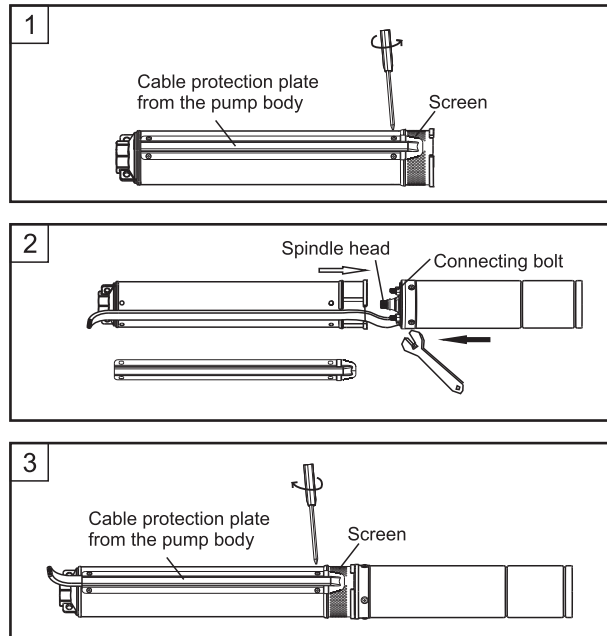

3.5 Before use, thoroughly test the insulation resistance of the electronic pump's stator winding (including outgoing cable) to the pump casing with a 500V megohmmeter, and the cold insulation resistance should be not less than 100 MΩ.

3.6 The electric pump shall be connected to the power source for trial operation before entering into water. The time shall not exceed 3 seconds. The cable lines of single-phase water pump shall be connected according to the wiring diagram on the electric machine or control cabinet strictly with correct colors. The wrong wiring will cause abnormal works or even damage the electric machine; three-phase water pump can be connected without differentiating cable colors.

3.7 A power line can be added with rather distant power supply. Please select proper cable lines according to table to avoid too thin cable that will lead to abnormal operation.

### 380-415V 50/60Hz

3 Phase Motor		Recommend to use H07RN-F / Cable Length / Cross-sectional Area Of Conductor(mm <sup>2</sup> )					
kW	HP	0-20m	21-40m	41-60m	61-80m	81-100	100-120m
3	4	1.5	2	2	2.5	3	4
4	5.5	2	2.5	2.5	3	4	5
5.5	7.5	2.5	3	3	5	5	6
7.5	10	3	4	5	6	8	8
9.2	12.5	3	4	5	8	8	10
11	15	4	5	6	8	10	12
13	17.5	4	5	8	10	12	16
15	20	5	6	v	10	12	16
18.5	25	5	6	10	12	16	20
22	30	6	8	12	16	20	25
26	35	6	8	16	20	20	30
30	40	8	10	16	20	25	30
37	50	8	12	20	25	30	40
45	60	10	16	25	30	40	50
55	75	10	20	32	35	50	60
63	85	12	20	32	50	50	70
75	100	12	25	35	50	70	80
90	120	16	32	50	70	70	95
110	150	20	35	50	70	95	120

To choose the required cutting area of cable according to the power of pump and length of external cable to ensure the normal operation of motor.

3.8 Please operate as below instructions for adding cable lines:

3.8.1 Strip the cable by 50-60mm with a wire stripper, then strip the rubber hose to reveal a 20-30mm copper wire.

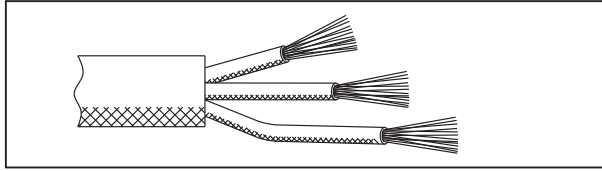

3.8.2 Tighten two cable lines with the same color into spiral shape so as to guarantee close connection;

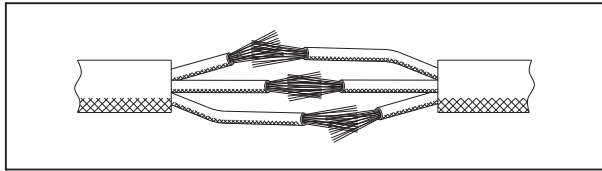

3.8.3 Tightly wind and cover the cable with the electrical insulating tape from the 15-20mm core cord.

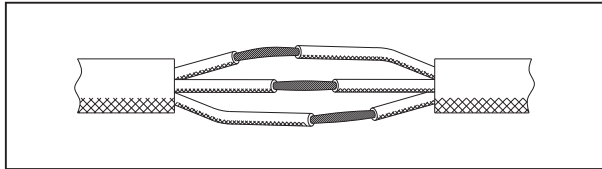

3.8.4 Wrap the cable that is covered with the electrical insulating tape with a waterproof adhesive tape from the 20-30mm core cord. The waterproof adhesive tape should be 10mm longer than the electrical insulating tape at both ends. Before the wrapping, the waterproof tape should be stretched out 1-fold its length and follow the normal use.

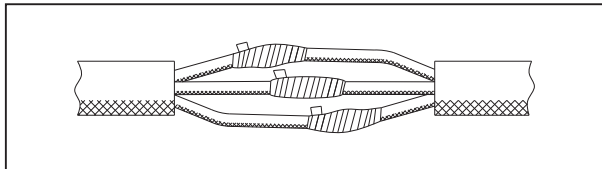

3.8.5 Wrap the cable that is wrapped with the waterproof adhesive tape with the electrical insulating tape.

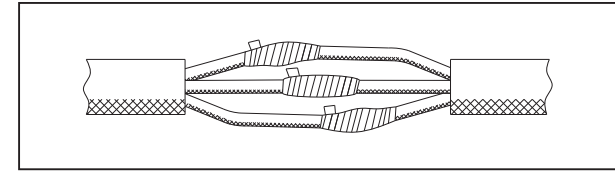

3.8.6 Wrap the cable that is wrapped with the electrical insulating tape with the waterproof adhesive tape. The waterproof adhesive tape should be 10mm longer than the electrical insulating tape at both ends. Before the wrapping, the waterproof tape should be stretched out 1-fold its length and follow the normal use.

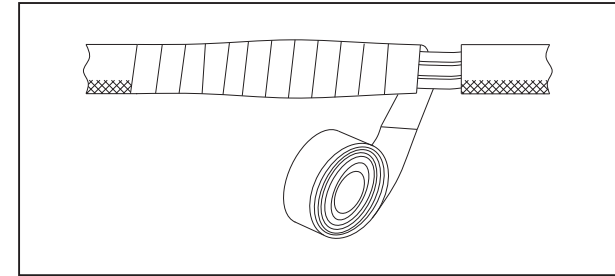

3.8.7 Immerge the junction of the cable into water for 12 hours. Test the insulation resistance of the cable with the 500V megohmmeter. The cold insulation resistance should be not less than 50 MΩ

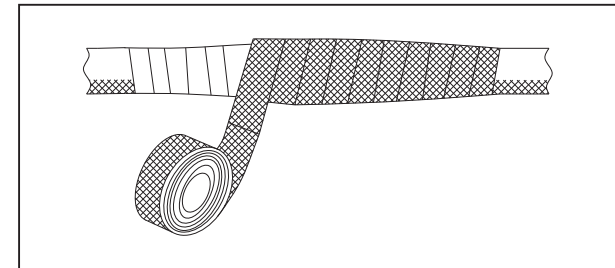

3.9 The delivery pipe shall be matched to the water outlet ( the specification shall be selected based on performance parameter table ). For example, the iron wire or clamp can be used to connect with soft delivery pipes; the screwed joint can be used for steel delivery pipes for further reliable connection. Further , the threading ropes are used at the handle in case of lifting in the water. The tied

ropes of hoisting electric pump must be firm and durable. The cable lines shall not be stretched but in a natural loose state.

3.10 The cables are not allowed for impact and crushing or used as lifting ropes. Further, do not pull the cables randomly during operation so as to avoid electric shock caused by cable damage.

3.11 The depth of electric pump in the water shall not be over 80m but 3m above the bottom. Further, the electric pump shall not be sunk into soils. Meanwhile, the user shall prevent sundries to block nets or impellers, because it will lead to abnormal works. Please check the water level during works to avoid exposed or dry works, or else it will burn the electrical machine and other parts.

3.12 During usage, washing, swimming or animals are not allowed within working regions. The safety warning label "electric shock risk, no entry" shall be set up on the site to prevent accidents.

3.13 The power source shall be cut off at the time of adjusting position or contacting with electric pumps in case of any accidents. The electric pump shall not be lifted away from water surface after shutting down power source so as to guarantee safety.

3.14 The electric pump belongs to specialized technology-based product. The unqualified repairman shall not conduct any random disassembly. The sealing and insulation testing must be conducted after laid-up and reassembly.

3.15 The maintenance shall be conducted on electric pumps after 3,000 hours normal operation. Various easily damaged parts such as mechanical seal, bearing and impeller etc must be replaced. The air pressure test must be conducted on motor and oil chambers after laid-up or changing mechanical seal. The test pressure is 0.4 Mpa. There shall be no leakage within five minutes.

3.16 The pump shall not be sunk into water for long-term nonuse. Instead, the pump shall be put in the clear water for several minutes of operation so as to clean mud etc inside and outside the pump. Further, the anti-rust oil shall be coated on the pump that shall be put in a dry and ventilated place. The electric pump with rather long-term use shall be repainted or treated by anti-rust oil according to its surface corrosion status.

## WIRING DIAGRAM

Three phase with three cable connection demonstration

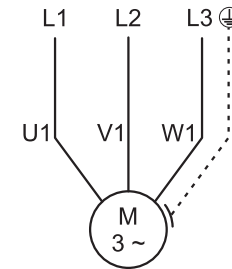

Three-Phase Motor Lead Identification

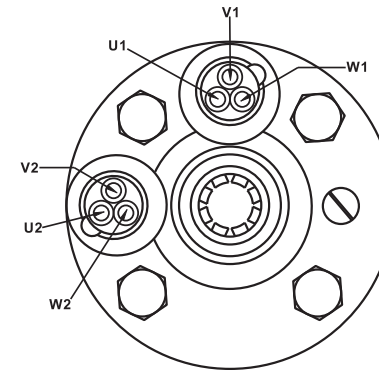

Three phase with six cable Y connection demonstration

● Connections for across-the-line starting, running, and any reduced voltage starting except WYE-DELTA type starters.

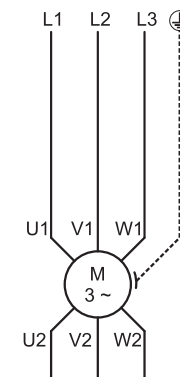

Three phase with six cable Δ connection demonstration

● WYE-DELTA starters connect the motor as shown below during starting, then change to the running connection shown at the left.

